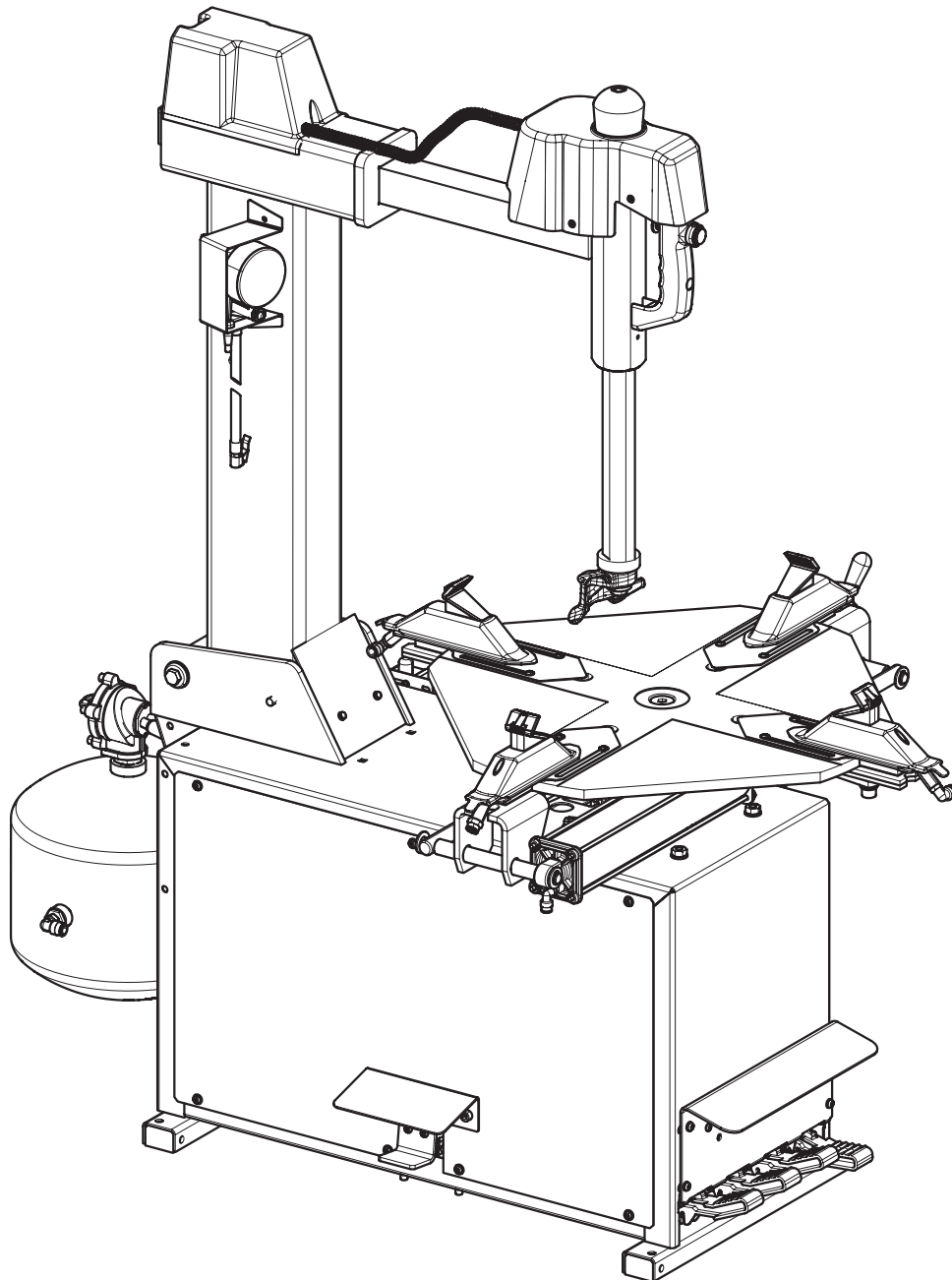




## R141I Series Tyre Changer



**P  
A  
R  
T  
S**

**B  
R  
E  
A  
K  
D  
O  
W  
N**

# SUMMARY

<b>Table Number 1 - Rev. 1</b> _____ <b>4</b> <i>MAIN ASSEMBLY</i>	<b>Table Number 12 - Rev. 0</b> _____ <b>VS140990431</b> ..... <b>32</b> <i>PEDAL UNIT</i>
<b>Table Number 2 - Rev. 0</b> _____ <b>VS730094280</b> ..... <b>6</b> <i>FRAME UNIT</i>	<b>Table Number 13 - Rev. 1</b> _____ <b>VS730094611</b> ..... <b>34</b> <i>10"-24" GT CHUCK ASSEMBLY</i>
<b>Table Number 3 - Rev. 1</b> _____ <b>VS730091401</b> ..... <b>7</b> <i>AUTOMATIC POST UNIT</i>	<b>Table Number 14A - Rev. 1</b> _____ <b>VS730095700</b> ..... <b>36</b> <i>AIR TREATMENT UNIT</i>
<b>Table Number 4A - Rev. 0</b> _____ <b>VS730094220</b> ..... <b>10</b> <i>LATERAL CASING UNIT</i>	<b>Table Number 14B - Rev. 0</b> _____ <b>VS730095760</b> ..... <b>37</b> <i>AIR TREATMENT UNIT</i>
<b>Table Number 4B - Rev. 0</b> _____ <b>VS730094171</b> ..... <b>11</b> <i>LATERAL CASING UNIT</i>	<b>Table Number 15 - Rev. 0</b> _____ <b>VS140990371</b> ..... <b>38</b> <i>TUBELESS INFLATION PEDALBOARD</i>
<b>Table Number 5 - Rev. 0</b> _____ <b>VS730091291</b> ..... <b>12</b> <i>BEAD BREAKER ARM UNIT</i>	<b>Table Number 16 - Rev. 0</b> _____ <b>VS140790205</b> ..... <b>40</b> <i>INFLATION UNIT</i>
<b>Table Number 6A - Rev. 0</b> _____ <b>VS140390221</b> ..... <b>15</b> <i>ROTARY DISTRIBUTOR ASSEMBLY</i>	<b>Table Number 17 - Rev. 0</b> _____ <b>VS730092430</b> ..... <b>41</b> <i>AIR RESERVOIR ASSEMBLY</i>
<b>Table Number 6B - Rev. 0</b> _____ <b>VS140302093</b> ..... <b>16</b> <i>ROTARY DISTRIBUTOR ASSEMBLY</i>	<b>Table Number 18 - Rev. 0</b> _____ <b>VS140390580</b> ..... <b>43</b> <i>POST BASE PROTECTION UNIT</i>
<b>Table Number 7A - Rev. 0</b> _____ <b>VS730094110</b> ..... <b>17</b> <i>230-400-50 2 SPEED ASSEMBLY</i>	<b>Table Number 19 - Rev. 0</b> _____ <b>VS140390513</b> ..... <b>44</b> <i>SUPERIOR GUARD UNIT</i>
<b>Table Number 7B - Rev. 0</b> _____ <b>VS730092251</b> ..... <b>19</b> <i>240-50-60 0,75 KW INVERTER SPEED ASSEMBLY</i>	<b>Table Number 20 - Rev. 1</b> _____ <b>VS730091270</b> ..... <b>45</b> <i>TILTING POST PISTON UNIT</i>
<b>Table Number 8A - Rev. 1</b> _____ <b>VS730095842</b> ..... <b>21</b> <i>PEDALBOARD UNIT</i>	<b>Table Number 21 - Rev. 0</b> _____ <b>VS140392740</b> ..... <b>46</b> <i>TILTING POST FULCRUM UNIT</i>
<b>Table Number 8B - Rev. 1</b> _____ <b>VS730094270</b> ..... <b>24</b> <i>4-PEDAL 2-SPEED PEDALBOARD UNIT</i>	
<b>Table Number 9 - Rev. 0</b> _____ <b>VS140990391</b> ..... <b>26</b> <i>BEAD BREAKING PEDAL UNIT</i>	
<b>Table Number 10 - Rev. 0</b> _____ <b>VS140990401</b> ..... <b>28</b> <i>CHUCK PEDAL ASSEMBLY</i>	
<b>Table Number 11 - Rev. 0</b> _____ <b>VS730094200</b> ..... <b>30</b> <i>2 SPEEDS OVERSIZE PEDAL ASSEMBLY</i>	



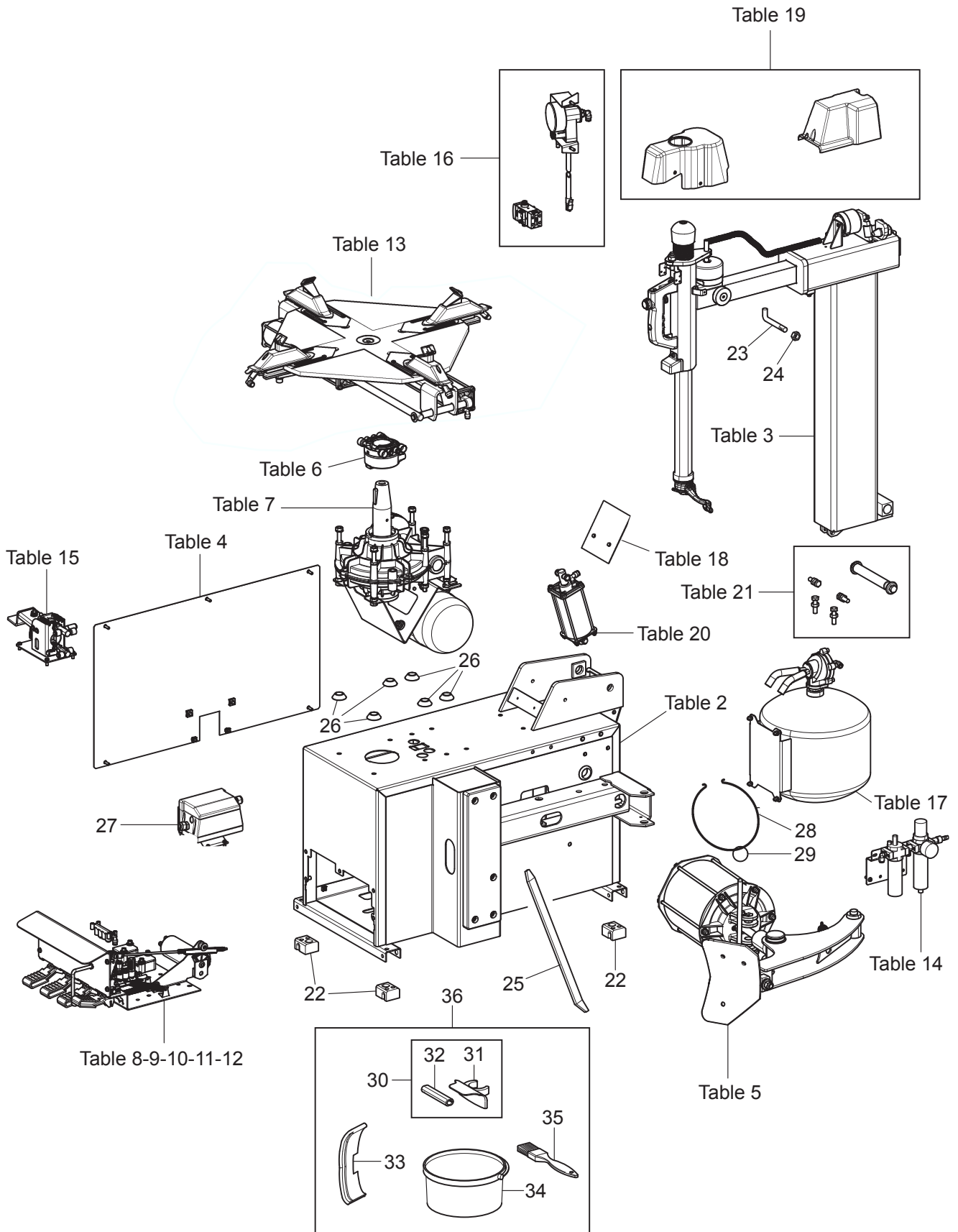
**IN THIS DOCUMENT THE FOLLOWING GRAPHIC REPRESENTATION IS ADOPTED TO INDICATE THE VALIDITY OF THE TABLE AND OF THE VARIOUS COMPONENTS ACCORDING TO THE SERIAL NUMBER OF THE MACHINE.**



**Symbol indicating "starting from serial number".**

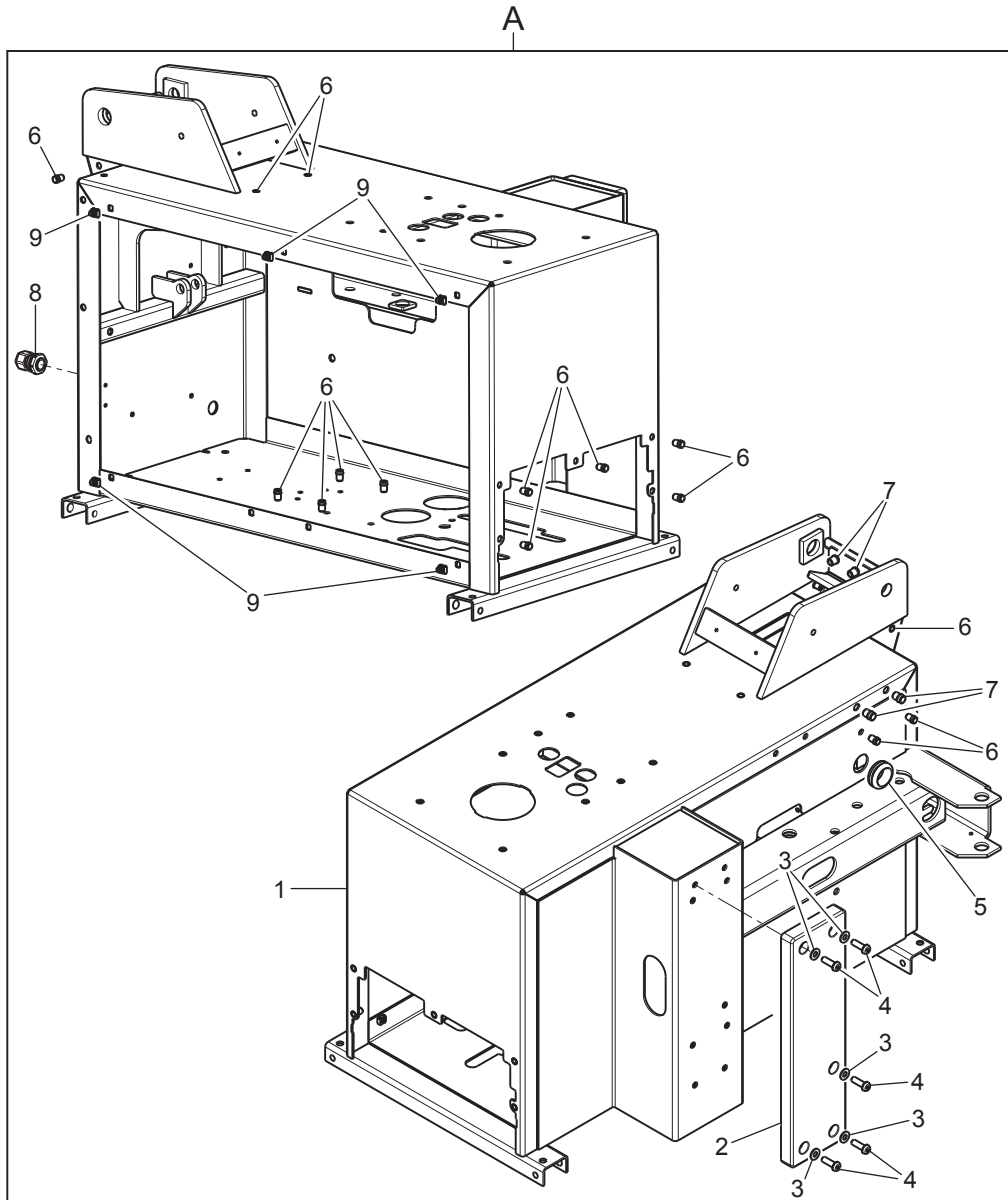


**Symbol indicating "up to serial number".**

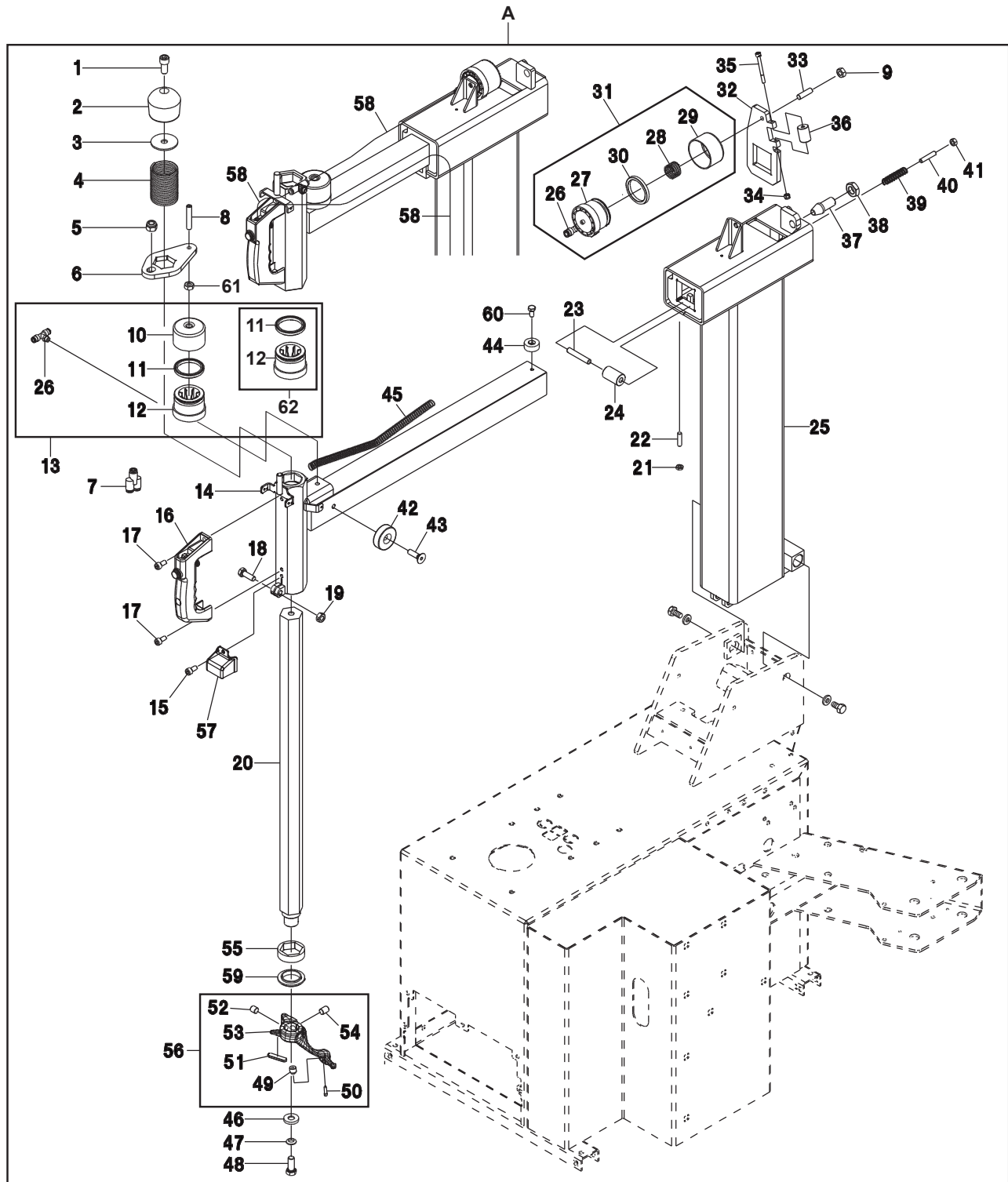




**Table Number 1 - Rev. 1**

<b>Table.Rev</b>	<b>Code</b>	<b>Pos.</b>	<b>RC141SD.24I</b>	<b>RC141SQ.24I</b>	<b>⇨</b>	<b>⇨</b>
2	VS730094280		•	•		
3	VS730091401		•	•		
4A	VS730094220					
4B	VS730094171		•	•		
5	VS730091291		•	•		
6A	VS140390221					
6B	VS140302093		•	•		
7A	VS730094110			•		
7B	VS730092251		•			
8A	VS730095842		•			
8B	VS730094270			•		
9	VS140990391		•	•		
10	VS140990401		•	•		
11	VS730095720			•		
12	VS140990431		•	•		
13	VS730094611		•	•		
14A	VS730095700					
14B	VS730095760		•	•		
15	VS140990371		•	•		
16	VS140790205		•	•		
17	VS730092430		•	•		
18	VS140390790		•	•		
19	VS140390513		•	•		
20	VS730091270		•	•		
21	VS140392740		•	•		
	VS140315440	22				
	VS140330740	23				
	VS224007	24				
	VSG1000A52	25	•	•		
	VS730015400	26	•	•		
	VS730017041	27	•	•		
	VS730095750	28	•	•		
	VS903090	29	•	•		
	VSG800A117	30	•	•		
	VS770012480	31	•	•		
	VSB9837000	32	•	•		
	VSG800A11	33	•	•		
	VSG800A37	34	•	•		
	VSG800A38	35	•	•		
	VS730095340	36	•	•		
	VS730096770	36	•	•		





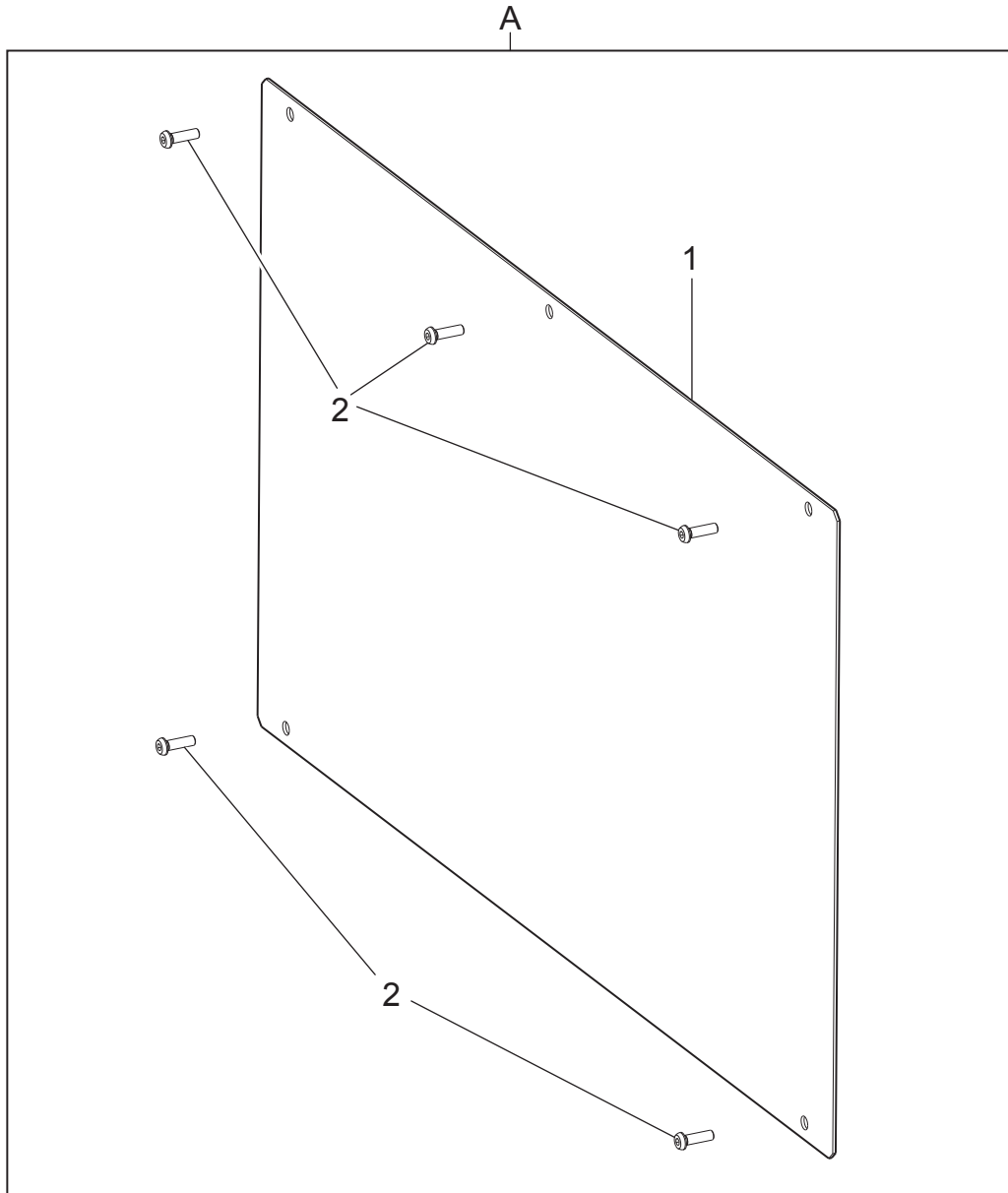
N°	Code	Description	Description	Descripción
1	VS730023350Y	Frame		
2	VSB4382000	Pad		
3	VS236006	8,4 flat washer		
4	VS271038	TBEI M8X25 screw		
5	VS599418	Rubber-made fairlead		
6	VS251107	M6 threaded insert		
7	VS251109	Threaded assembly		
8	VSAG-20B	Cable press		
9	VS228250	M6 crated nut		
A	VS730094280	Frame unit		



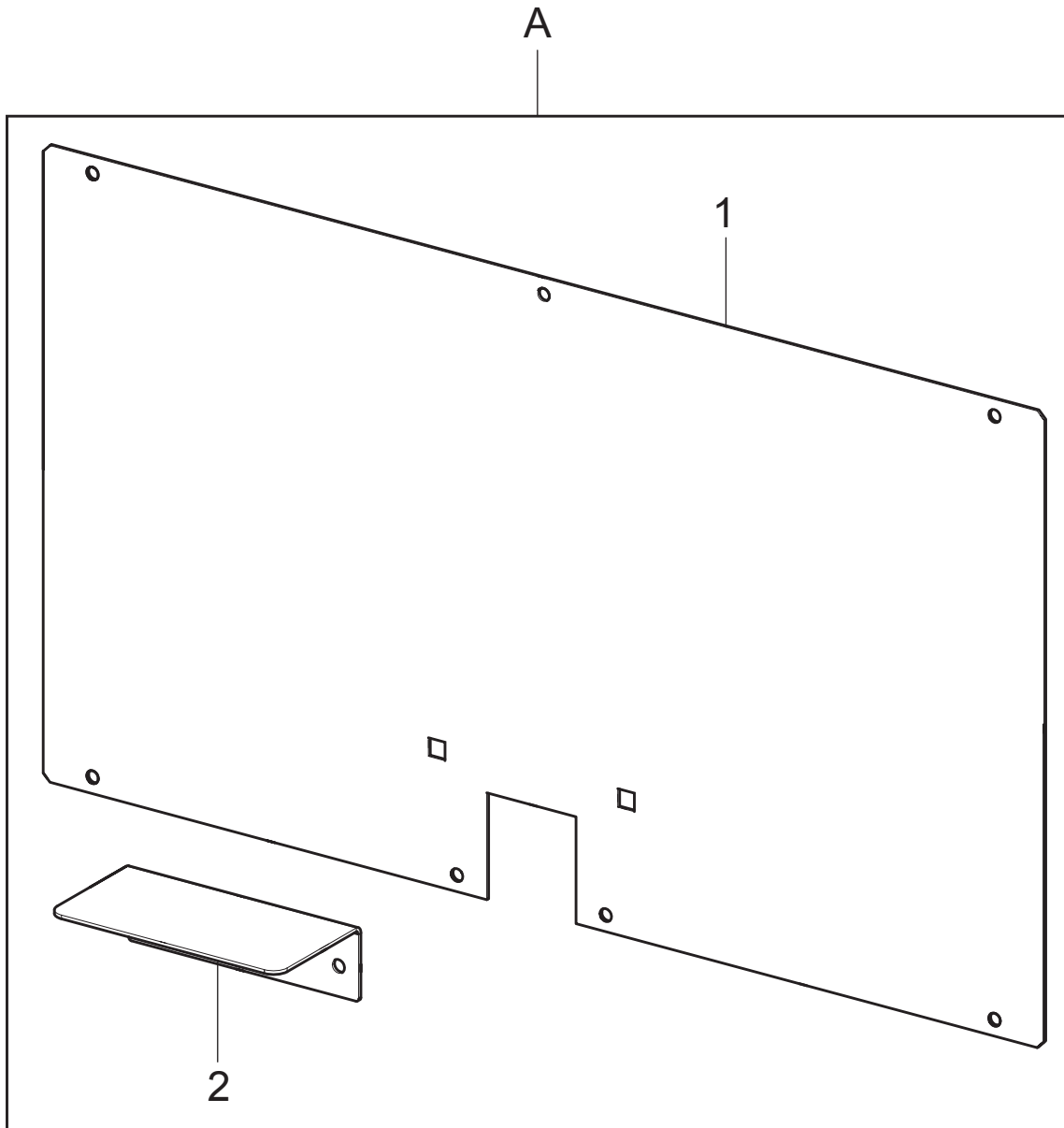
<b>Table Number 3 - Rev. 1</b>		<b>VS730091401</b>			
<b>N°</b>	<b>Code</b>	<b>Description</b>	<b>Description</b>	<b>Descripción</b>	
1	VS206186	TCEI M12x25 screw			
2	VS140710160	Vertical shaft handgrip			
3	VS140320310	Washer			
4	VS950001641Y	Spring			
5	VS228006	M12 self-locking nut			
6	VS140710092Y	Neck			
7	VS75606	Y-6 pneumatic union			
8	VS210904	STEI M12x42.1 screw			
9	VS224011	M10 middle hexagonal nut			
10	VS730021270	D.80 barrel			
11	VS402130	Gasket			
12	VS730021260	D.80 piston			
13	VS730093400	D.80 neck cylinder			
14	VS730017173Y	Horizontal square			
15	VS271012	TBEI M6x10 screw			
16	VSB2859001	C complete handle			
17	VS206031	TCEI M8x14 screw			
18	VS256902	M10x30 screw			
19	VS228310	M10 nut			
20	VS140415391Y	Shaft			
21	VS226009	M8 low nut			
22	VS210040	STEI M8x30 screw			
23	VSB50-10*60	10x60 cylindrical pin			
24	VS730014560Y	Roller			
25	VS730019050Y	Welded rod			
26	VS325102	1/8x6 fixed union			
27	VSB2600000	D. 60 piston with 1/8" thread.			
28	VSB2605000	2x29,5x40 Zn C spring			
29	VS14030121	Cylinder			
30	VS402059	Gasket			
31	VSB2871000	Rear neck cylinder			
32	VS730014580Y	Rear neck			
33	VS210902	STEI M10x41,9 screw			
34	VS228010	M6 autoblock nut			
35	VS206335	TCEI M6x65 screw			
36	VS140910700Y	Neck roller			
37	VS140910711Y	Neck cone			
38	VS226024	M18 low hexagonal nut			
39	VS950001510Y	Spring			



<b>Table Number 3 - Rev. 1</b>		<b>VS730091401</b>			
<b>N°</b>	<b>Code</b>	<b>Description</b>	<b>Description</b>	<b>Descripción</b>	
40	VS210042	M8x40 STEI flat screw			
41	VS224009	M8 middle hexagonal nut			
42	VS730012451	Pad			
43	VS209106	TSPEI M10x35 screw			
44	VS13830247	Pad			
45	VSB1408300Y	1x14x600 C spring			
46	VS140440380Y	Tower clamping washer			
47	VS140440390Y	Ball washer			
48	VS203072	TE M12x30 screw			
49	VSB9874000	Roller for assembling tool			
50	VSB9875000	Assembling tool roller pin			
51	VSB9837000	Tool tail guard			
52	VS210317	M12x12 STEI flat screw			
53	VS730019300	Assembling tool			
54	VS210069	M12x16 STEI flat screw			
55	VS140315721	40 hexagon pad			
56	VS730092730	Assembling tool			
57	VS730017850	Guard			
58	VS317006	6x4 black rilsan pipe L=4500			
59	VS790011540Y	Spacer for hexagon			
60	VS203172	TE M8x16 screw			
61	VS224015	M12 middle hexagonal nut			
62	VS730070240	Cylinder spare kit			
A	VS730091401	Automatic post unit			



N°	Code	Description	Description	Descripción
1	VS730023570Y	Lateral casing		
2	VS271021	VTBEI M6x20		
A	VS730094220	Lateral casing unit		



N°	Code	Description	Description	Descripción
1	VS730094171-1Y	Lateral casing		
2	VS730094171-2Y	Pedal black guard		
A	VS730094171	Lateral casing unit		

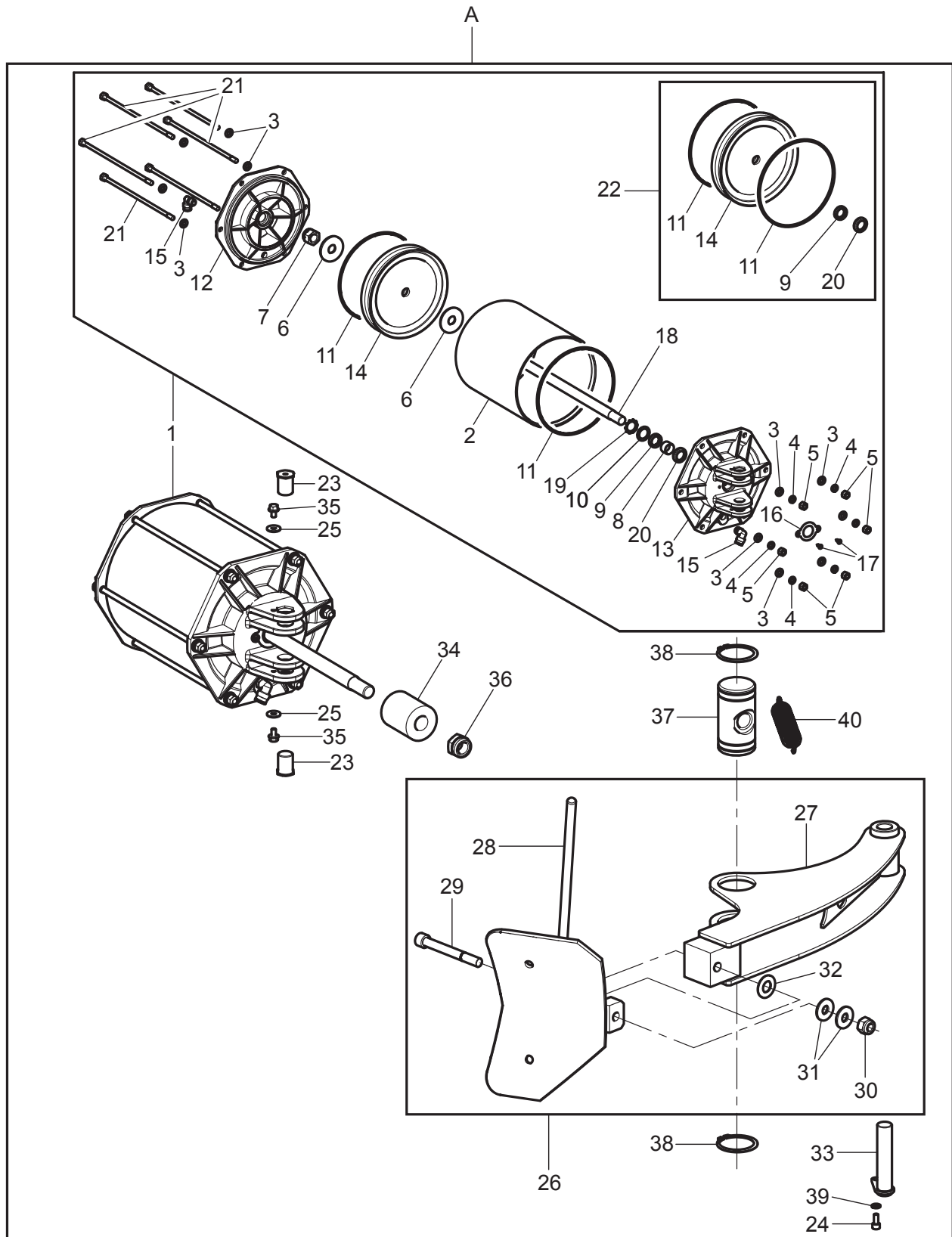
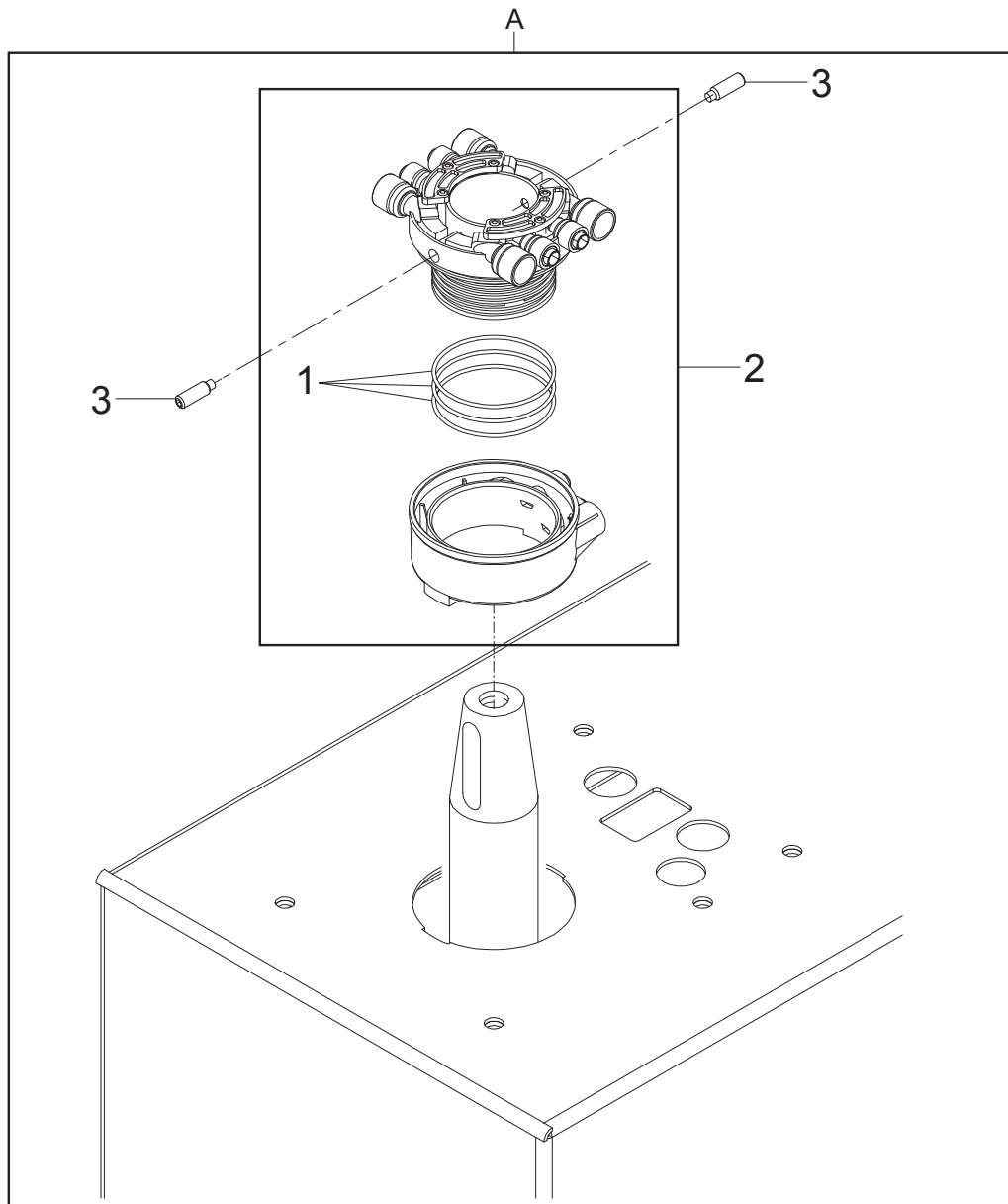
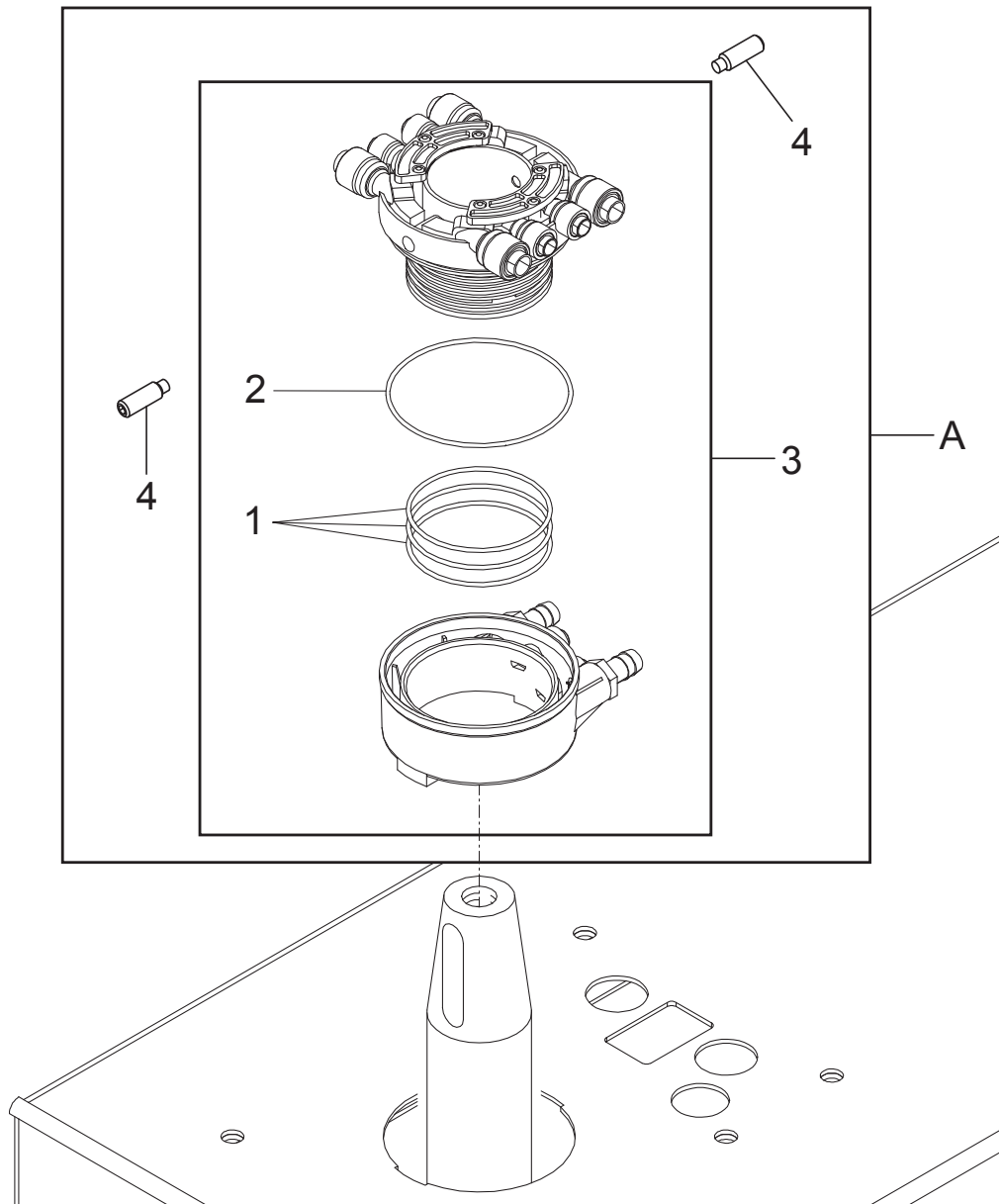


Table Number 5 - Rev. 0		VS730091291		→	←
N°	Code	Description	Description	Descripción	
1	VS730091221	Bead breaking cylinder			
2	VS730013991	Cylinder bead-breaker barrel			
3	VS236006	8,4 flat washer			
4	VS238006	8,4 elastic washer			
5	VS222009	M8 high nut			
6	VS140920380	D.54x18x4 washer			
7	VS228020	18x1,5 selflocking nut			
8	VS630035	Bushing			
9	VS403108	Gasket			
10	VS140920190	Gasket washer			
11	VS401196	O-ring 183,74x3,53			
12	VS140920550	Rear flange			
13	VS140920201	Front flange			
14	VS140920140	Bead-breaker gasket			
15	VS325107	L rotary union			
16	VS140912071	Plate			
17	VS220063	TCB M4,2x13 screw			
18	VS730013981	Rod			
19	VS299133	Seeger			
20	VS050670020	Scraper			
21	VS730014001	Tie rod for cylinder			
22	VSGU4090	Piston gasket set			
23	VS140920361Y	Cylinder fulcrum pin			
24	VS206012	TCEI M6x10 screw			
25	VS237011	ø6x18 flat washer			
26	VS730092401Y	Bead breaker arm assembly			
27	VS730026670Y	Arm			
28	VS140320083Y	Vane			
29	VS140925901	Screw for bead-breaker arm			
30	VS228006	M12 self-locking nut			
31	VS237069	Flat washer			
32	VS253017	Belleville washer			
33	VS140320430Y	Arm fulcrum pin			
34	VS140320361Y	Cam			
35	VS269201	M6X10 TE self-drilling screw			
36	VS228015	M18 low nut			
37	VS730018720Y	Fulcrum pin			
38	VS243022	External seeger			
39	VS239019	6,4 toothed washer			





N°	Code	Description	Description	Descripción
1	VSB7093000	2,62 x 64,77 O-ring		
2	VSB7096000	Rotary union		
3	VS211035	STEI M8x20 screw		
A	VS140390221	Rotary distributor assembly		



N°	Code	Description	Description	Descripción
1	VSB7093000	2,62 x 64,77 O-ring		
2	VSB7092000	OR gasket		
3	VSB7095000	FI rotary union		
4	VS211035	STEI M8x20 screw		
A	VS140302093	Rotary distributor assembly		



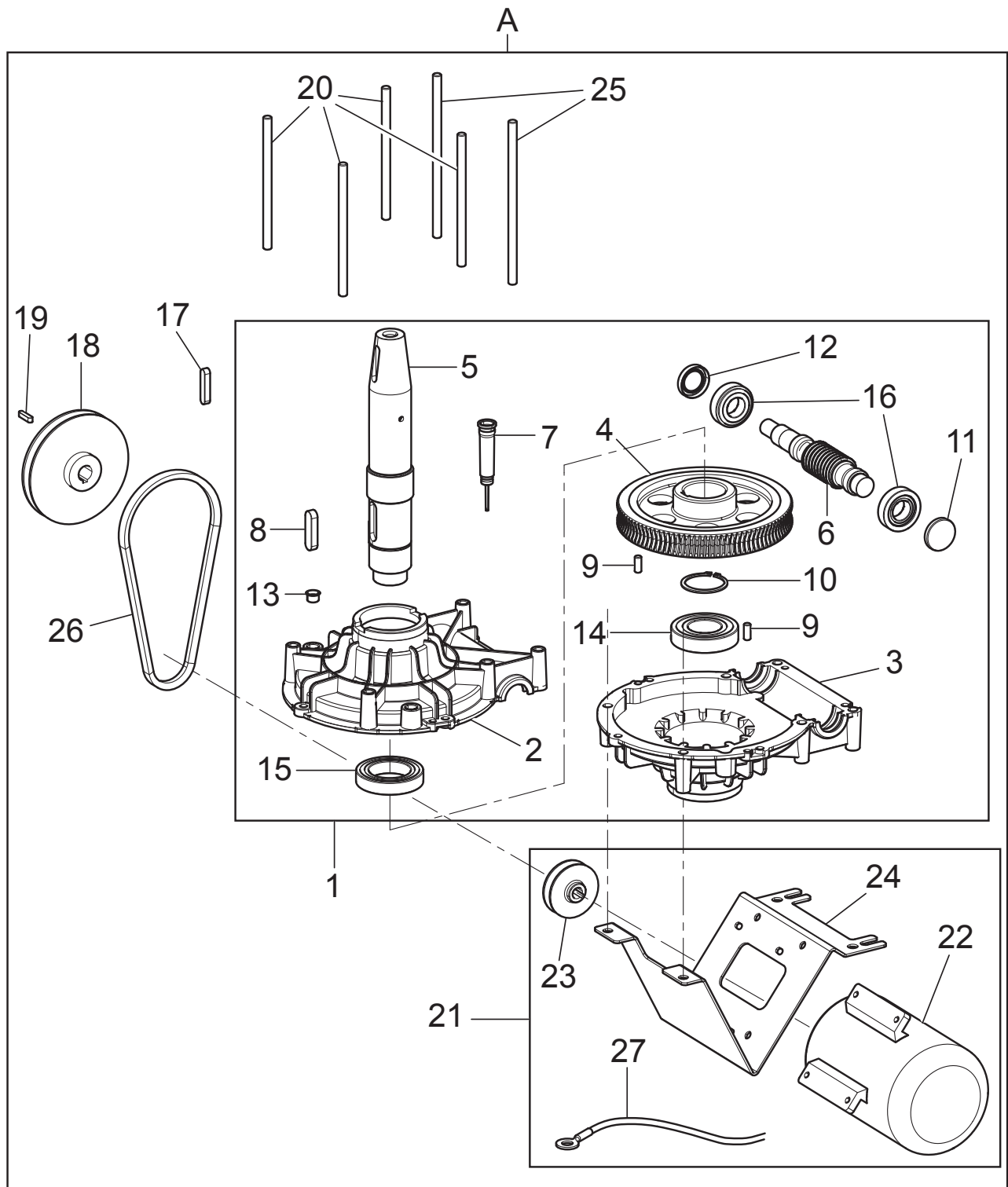


Table Number 7A - Rev. 0		VS730094110		→	←
N°	Code	Description	Description	Descripción	
1	VS140305521	Reduction gear assembly			
2	VS710516571	Upper half-body			
3	VS710516382	Lower half-body			
4	VS710216860	Crown wheel			
5	VS710217190	Shaft			
6	VS710216871	Worm screw			
7	VS140305610	Oil level rod			
8	VS231095	Tongue			
9	VS234169	8x20 cylindrical pin			
10	VS243022	External seeger			
11	VS412197	Closing plug			
12	VS404091	Oil seal ring			
13	VS413089	Cap			
14	VS601049	Radial bearing			
15	VS605048	Radial bearing			
16	VS607007	Bearing			
17	VS231068	10x8x45 wrench			
18	VS730012420	D.132 pulley			
19	VS231003	6x6x25 wrench			
20	VS14030532Y	M10x170 tie rod for reducer			
21	VS730093990	motor unit			
22	VS900001871	0.75 kW motor			
23	VS730020220	Pulley			
24	VS730023580Y	Motor support blade			
25	VS730023650Y	M10x180 tie rod for reducer			
26	VS412103	Trapezoidal belt			
27	VS730065050	Ground cable			
A	VS730094110	230-400-50 0,75 kW gearmotor assembly			

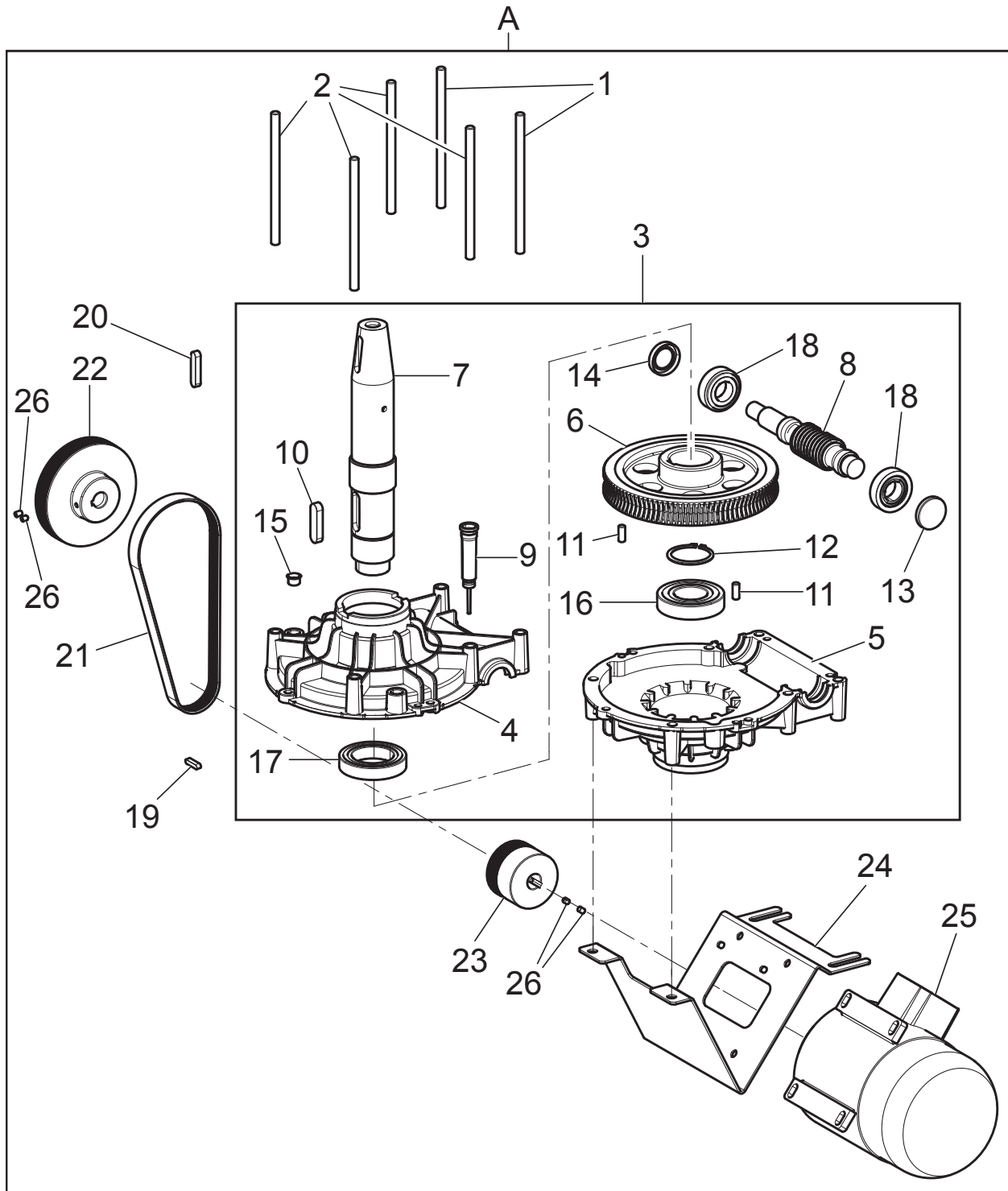


Table Number 7B - Rev. 0		VS730092251		←→	→←
N°	Code	Description	Description	Descripción	
1	VS14030528Y	Threaded bar M10x180			
2	VS14030532Y	M10x170 tie rod for reducer			
3	VS140305521	Reduction gear assembly			
4	VS710516571	Upper half-body			
5	VS710516382	Lower half-body			
6	VS710216860	Crown wheel			
7	VS710217190	Shaft			
8	VS710216871	Worm screw			
9	VS140305610	Oil level rod			
10	VS231095	Tongue			
11	VS234169	8x20 cylindrical pin			
12	VS243022	External seeger			
13	VS412197	Closing plug			
14	VS404091	Oil seal ring			
15	VS413089	Cap			
16	VS601049	Radial bearing			
17	VS605048	Radial bearing			
18	VS607007	Bearing			
19	VS231003	6x6x25 wrench			
20	VS231068	10x8x45 wrench			
21	VS239023	Belt			
22	VS730012420	D.132 pulley			
23	VS730014030	D.71 pulley			
24	VS730023580Y	Motor support blade			
25	VS900003720	Electric motor			
26	VS210126	STEI M6x8 screw			
A	VS730092251	motor unit with inverter			

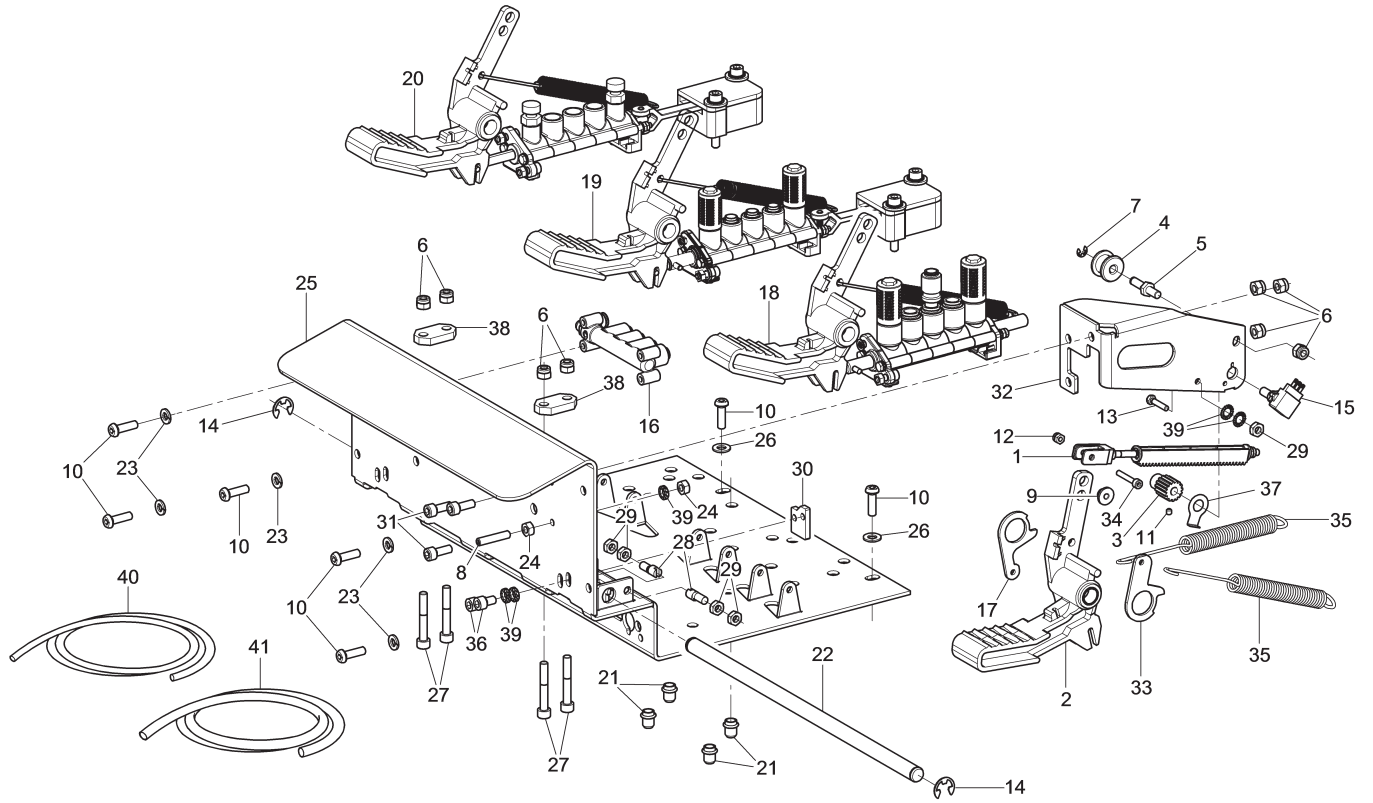
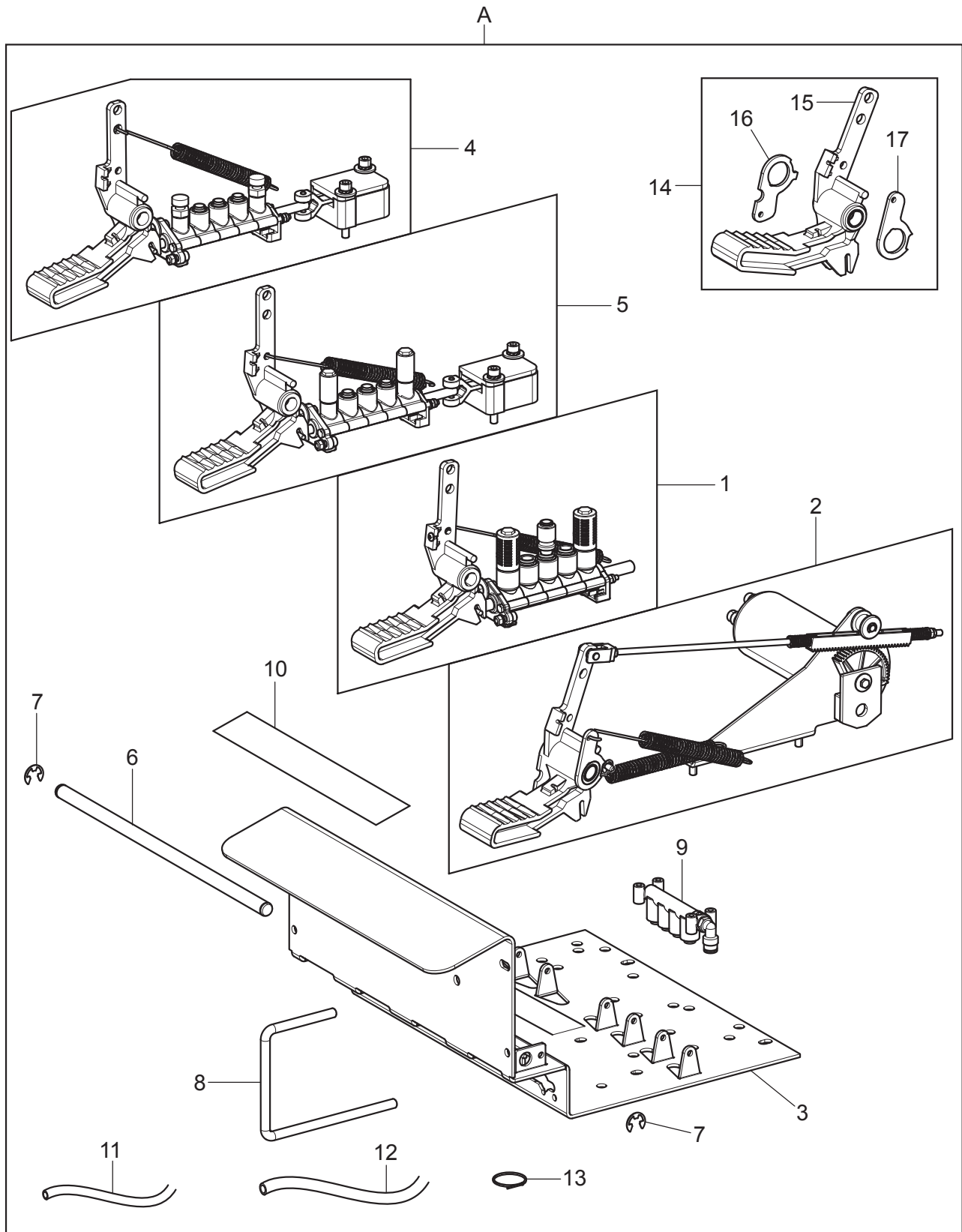


Table Number 8A - Rev. 1		VS730095842		→	←
N°	Code	Description	Description	Descripción	
1	VS730091040	Rack			
2	VS730091391	Pedal with bushings			
3	VS730011050	D.17 pinton gear			
4	VSB3837000	Rack roll			
5	VSB3934000	Pin for roll			
6	VS228010	M6 autoblock nut			
7	VS299042	D.4 stopper ring			
8	VS210128	M6 x 30 STEI flat screw			
9	VS730012310	Plug nut			
10	VS271021	TBEI M6 x 20 screw			
11	VS213485	STEI M4 x 4 screw			
12	VS228023	M4 self-locking nut			
13	VS203019	TE M6 x 16 screw			
14	VS299052	D.9 stopper ring			
15	VS710565010	Cable and potentiometer			
16	VSB2850001	5-way block			
17	VS730017990	Cam			
18	VS140990391	Bead breaking pedal unit			
19	VS140990401	Chcuk pedal assembly			
20	VS140990431	Pedal unit			
21	VS251102	Threaded insert			
22	VS140915170	Pedals fulcrum pin			
23	VS238004	6.4 elastic washer			
24	VS224007	M6 middle nut			
25	VS730014911	Pedalboard body			
26	VS237011	6 x 18 flat washer			
27	VS206094	TCEI M6 x 40 screw			
28	VS730014940	Stopper			
29	VS226007	M6 low nut			
30	VS730016430	Clamp			
31	VS206019	TCEI M6 x 16 screw			
32	VS140916001	Support			
33	VS730017980	Cam			
34	VS206231	TCEI M6 x 10 screw			
35	VS950001720	Inverter spring			
36	VS206012	TCEI M6 x 10 screw			
37	VS790011970	Safety washer			
38	VS730014920	Plate			
39	VS239019	6.4 toothed washer			



N°	Code	Description	Description	Descripción
40	VS317007	8 x 6 black rilsan pipe		
41	VS317010	10 x 8 black rilsan pipe		









A

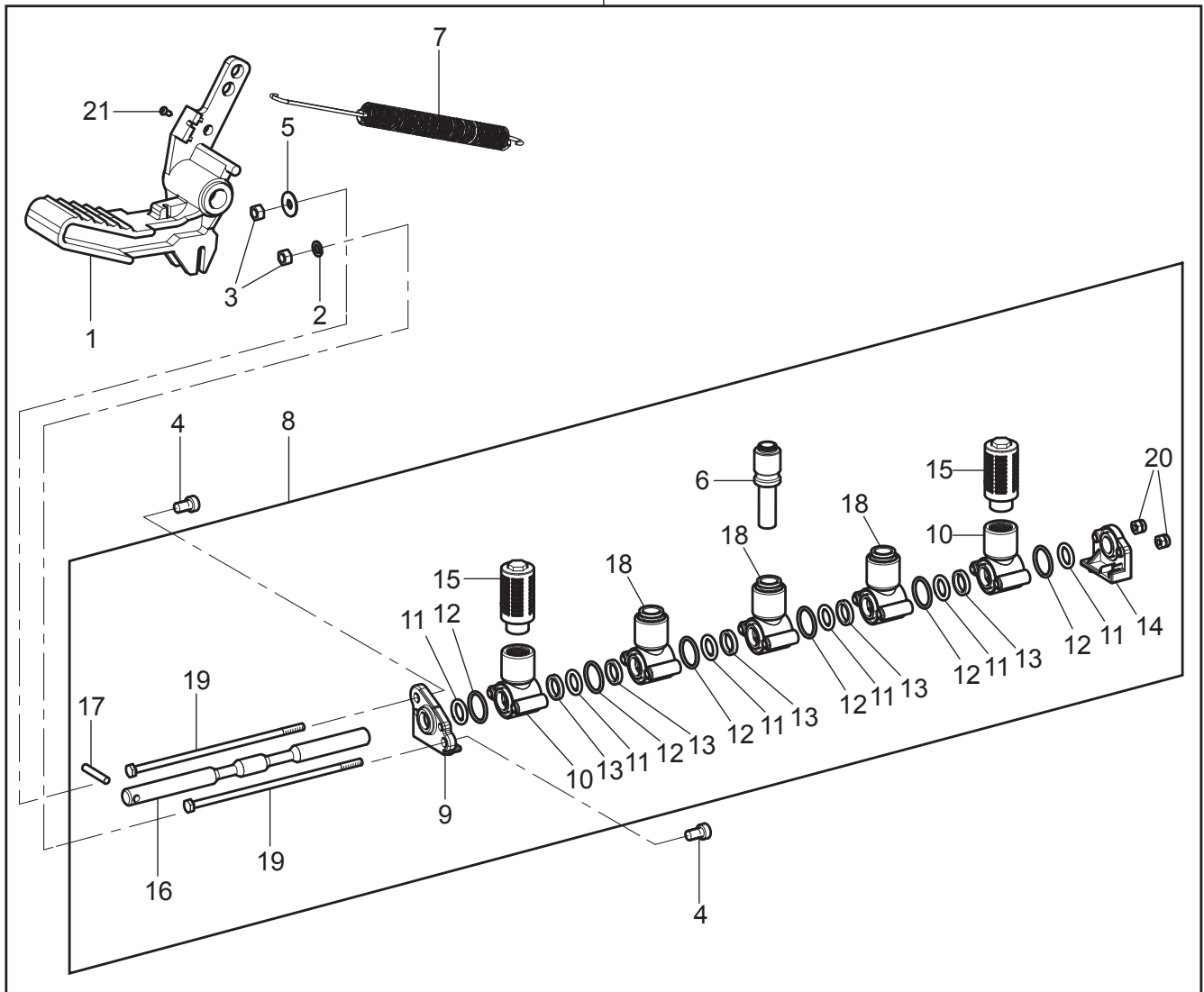
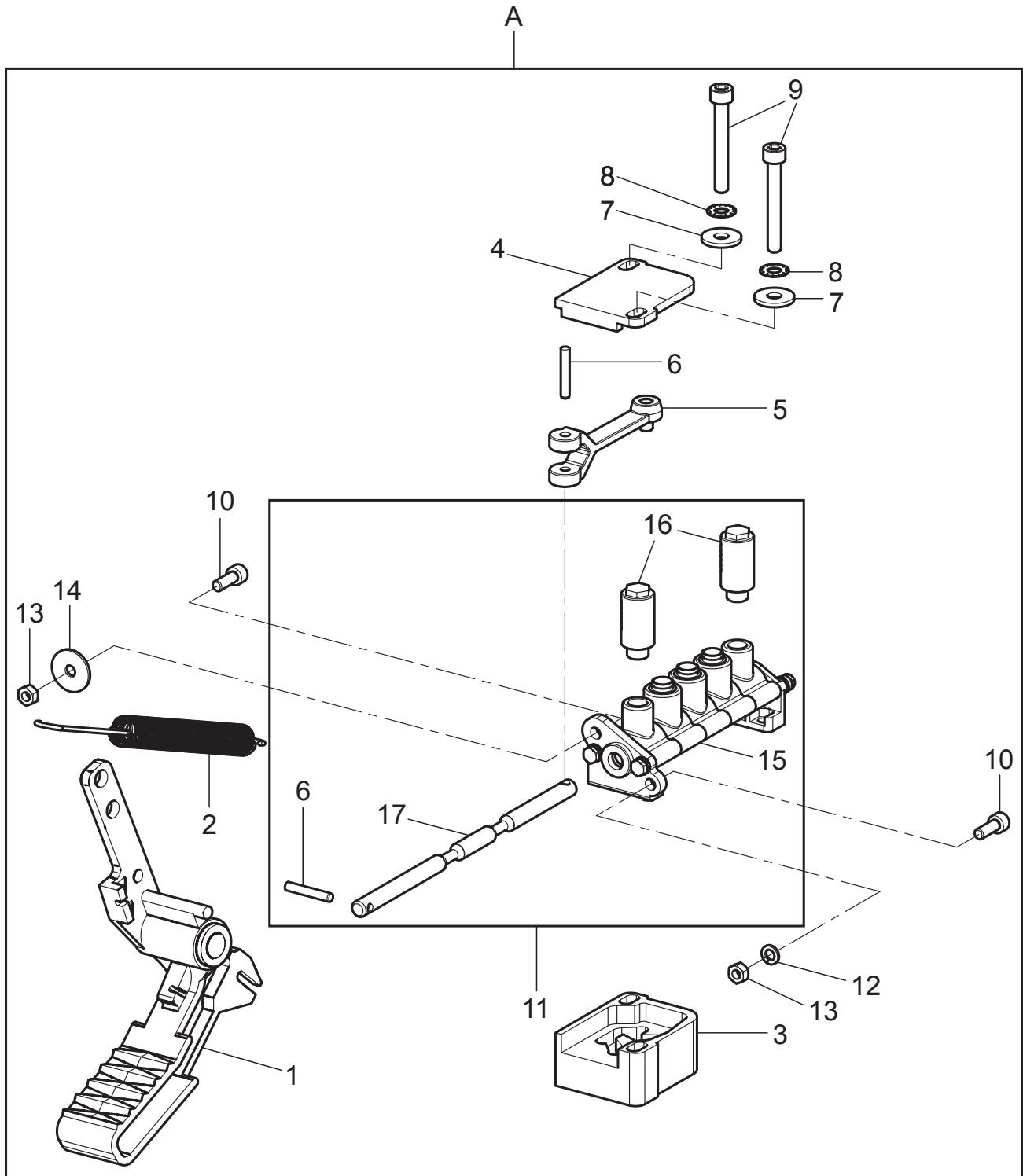
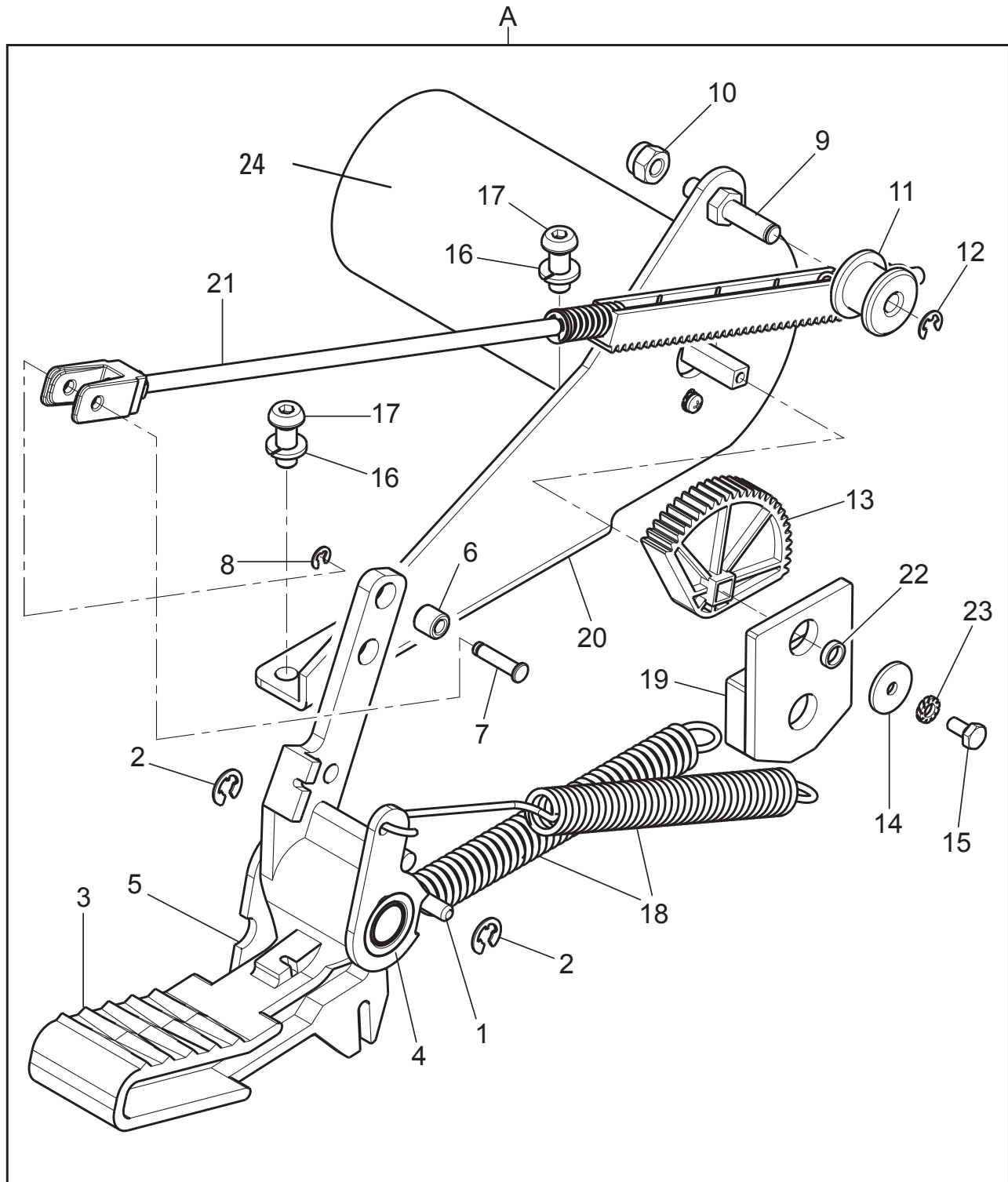




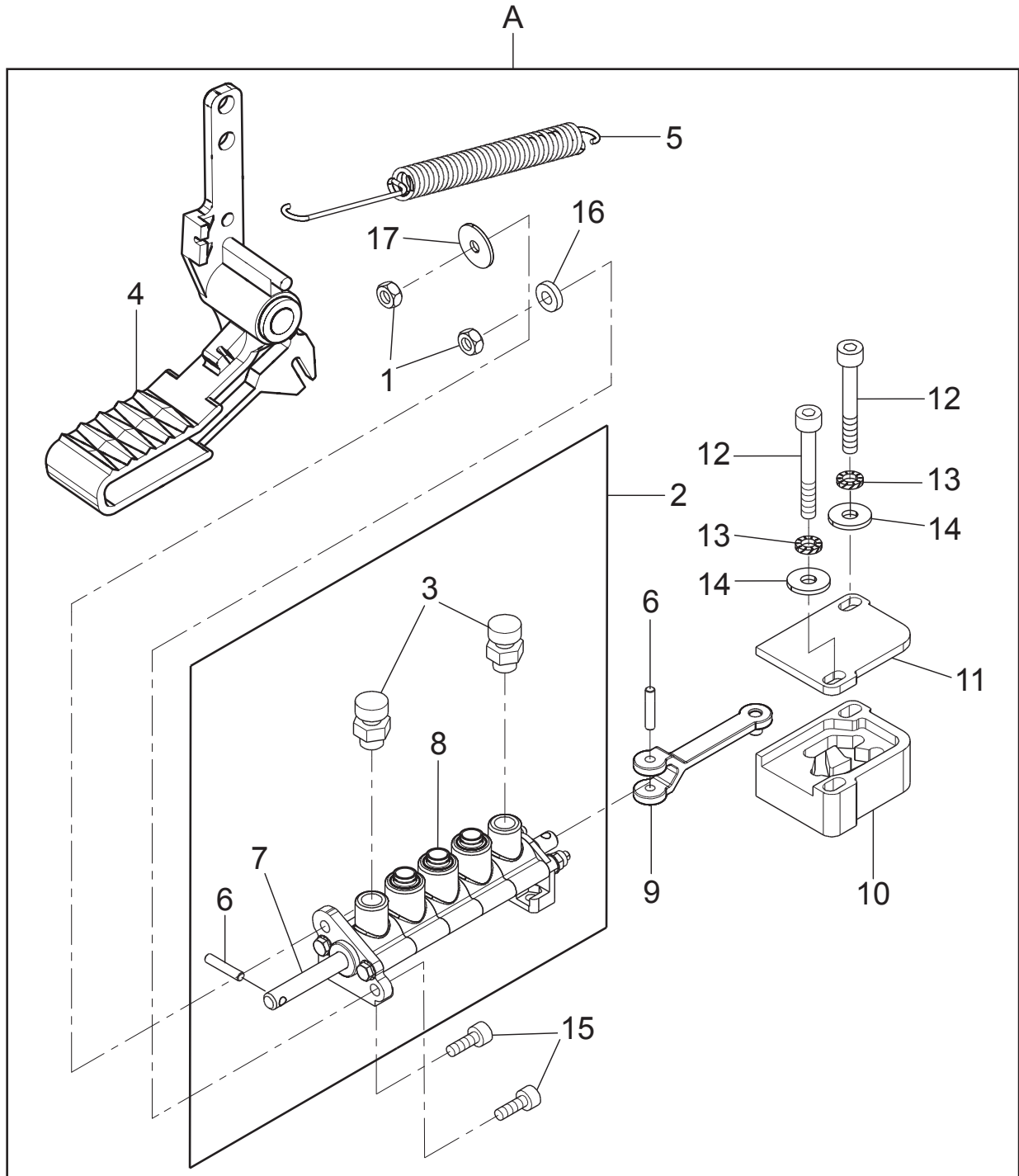
Table Number 9 - Rev. 0		VS140990391			
N°	Code	Description	Description	Descripción	
1	VS140915031	Pedal			
2	VS238026	Elastic washer			
3	VS224005	M5 middle nut			
4	VS206007	TCEI M5x14 screw			
5	VS237010	5x20x1,5 washer			
6	VS325227	10-8 reduction			
7	VS950001720	Inverter spring			
8	VS730091710	Bead breaker valve group			
9	VS730015470	Front bottom			
10	VS730015460	1/4 module valve			
11	VS401251	OR			
12	VS401091	OR 2062			
13	VS730016030	Washer			
14	VS730015480	Rear bottom			
15	VS399064	1/4" silencer			
16	VS730015491	Spool			
17	VS234036	Cylindrical pin			
18	VS730091860	D.10 cartridge module unit			
19	VSB3053000	M4 tie rod for valve			
20	VS228023	M4 self-locking nut			
21	VS220042	3,5x6,5 TCB screw			
A	VS140990391	Bead breaking pedal unit			





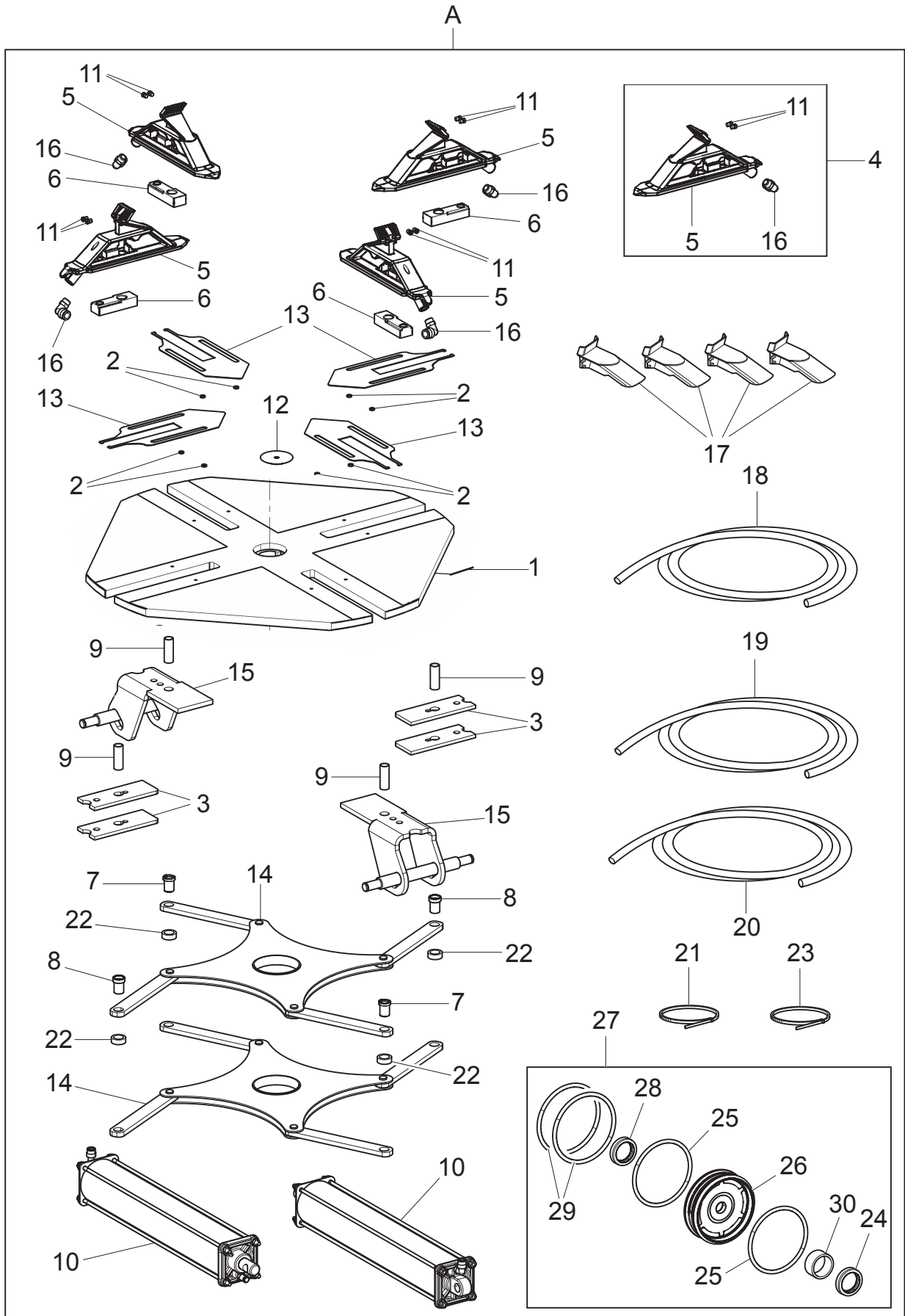


<b>Table Number 11 - Rev. 0</b>		<b>VS730094200</b>			
<b>N°</b>	<b>Code</b>	<b>Description</b>	<b>Description</b>	<b>Descripción</b>	
1	VS140915040	Pin			
2	VS299132	D.5 stopper ring			
3	VS730093041	Pedal with bushings			
4	VS140912002	Upper spring cam			
5	VS140912012	Lower spring cam			
6	VS140912020	Brass bushing			
7	VSB5165000	Pin for fork			
8	VS299151	3,2 ring			
9	VSB3934000	Pin for roll			
10	VS228010	M6 autoblock nut			
11	VSB3837000	Rack roll			
12	VS299042	D.4 stopper ring			
13	VSB3838000	6x6 toothed sector			
14	VS237021	Shear washer			
15	VS203228	TE M4x8 screw			
16	VS238004	6,4 elastic washer			
17	VS266019	TBEI M6x16 screw			
18	VS950001720	Inverter spring			
19	VS140912050	Pedalboard counterweight			
20	VS730095730	3 Ph 2 speeds 32 A commutator assembly			
21	VS730094010	Commutator control rod			
22	VS140916840	Spacer			
23	VS239018	4,3 toothed washer			
24	VS518288	3ph protection + commutator			
A	VS730094200	2 speeds oversize pedal assembly			

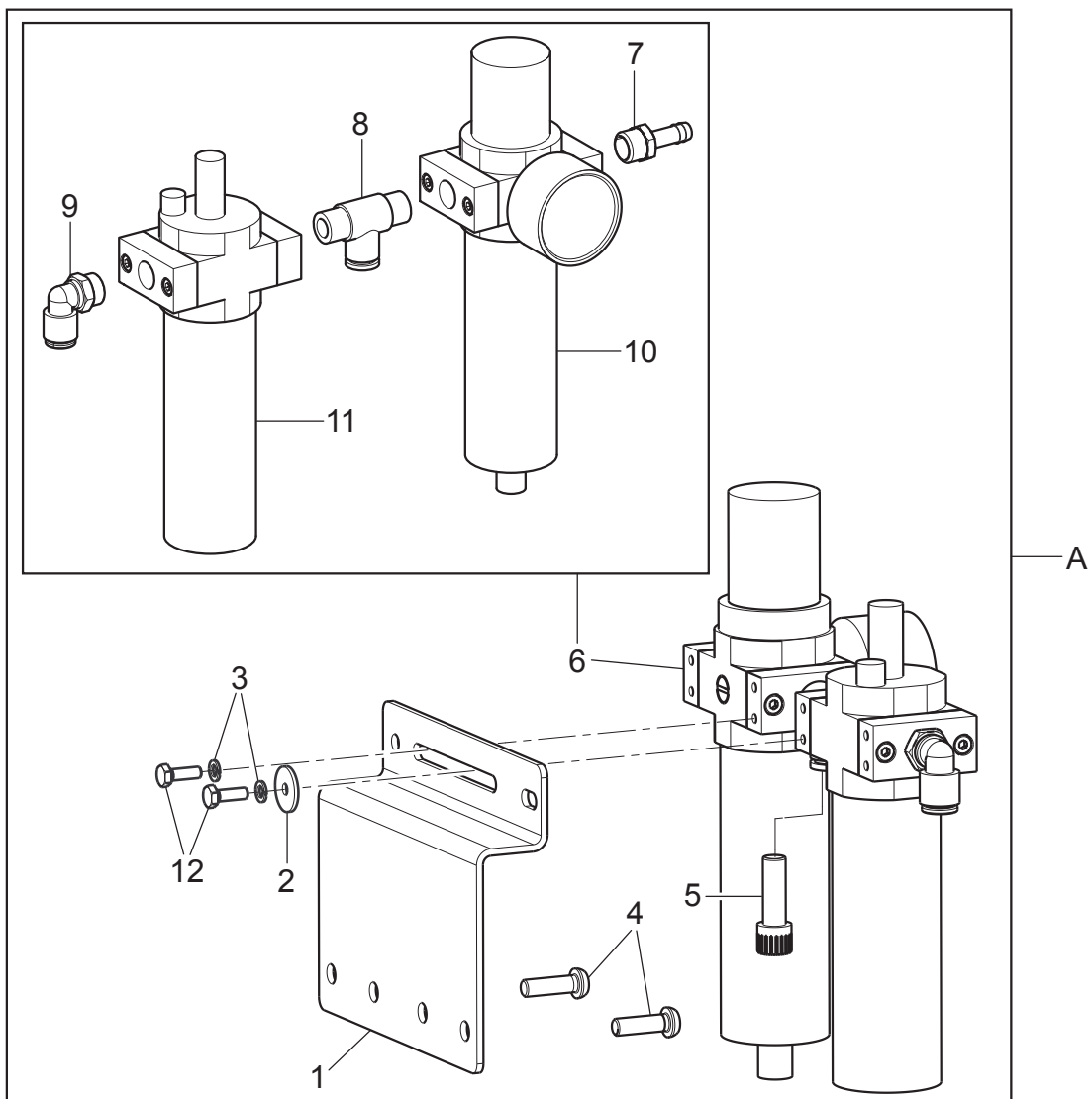




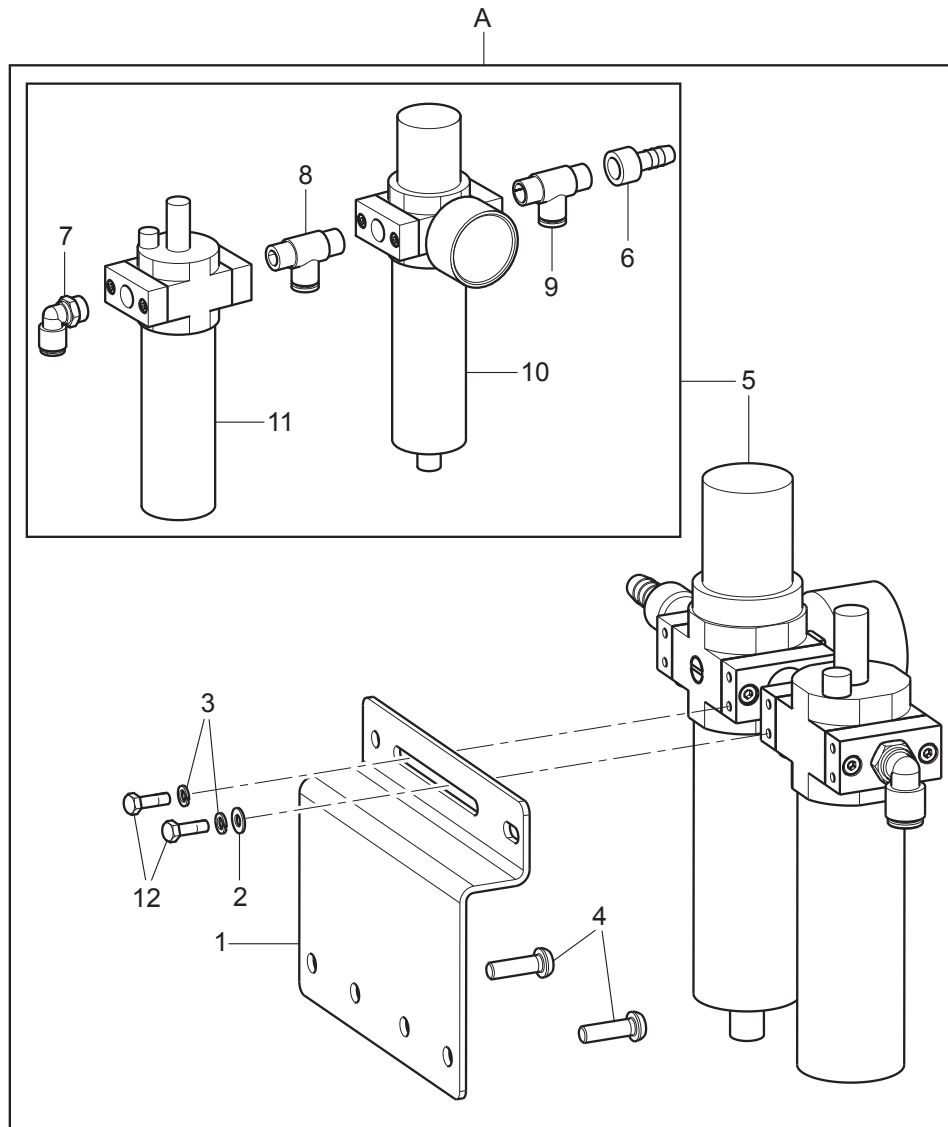
N°	Code	Description	Description	Descripción
1	VS224005	M5 middle nut		
2	VS140998062	Tilter distributor assembly		
3	VS325152	Flow regulator		
4	VS140915031	Pedal		
5	VS950001720	Inverter spring		
6	VS234036	Cylindrical pin		
7	VS140915133	Spool		
8	VS140998090	Cartridge		
9	VS140915161	Lever assembly		
10	VS140915101	Valve control cam		
11	VS140915111	Cam covering		
12	VS206096	TCEI M6x45 screw		
13	VS239019	Toothed washer		
14	VS237011	Ø6x18 flat washer		
15	VS206007	TCEI M5x14 screw		
16	VS238026	Elastic washer		
17	VS237010	5x20x1,5 washer		
A	VS140990431	Pedal unit		



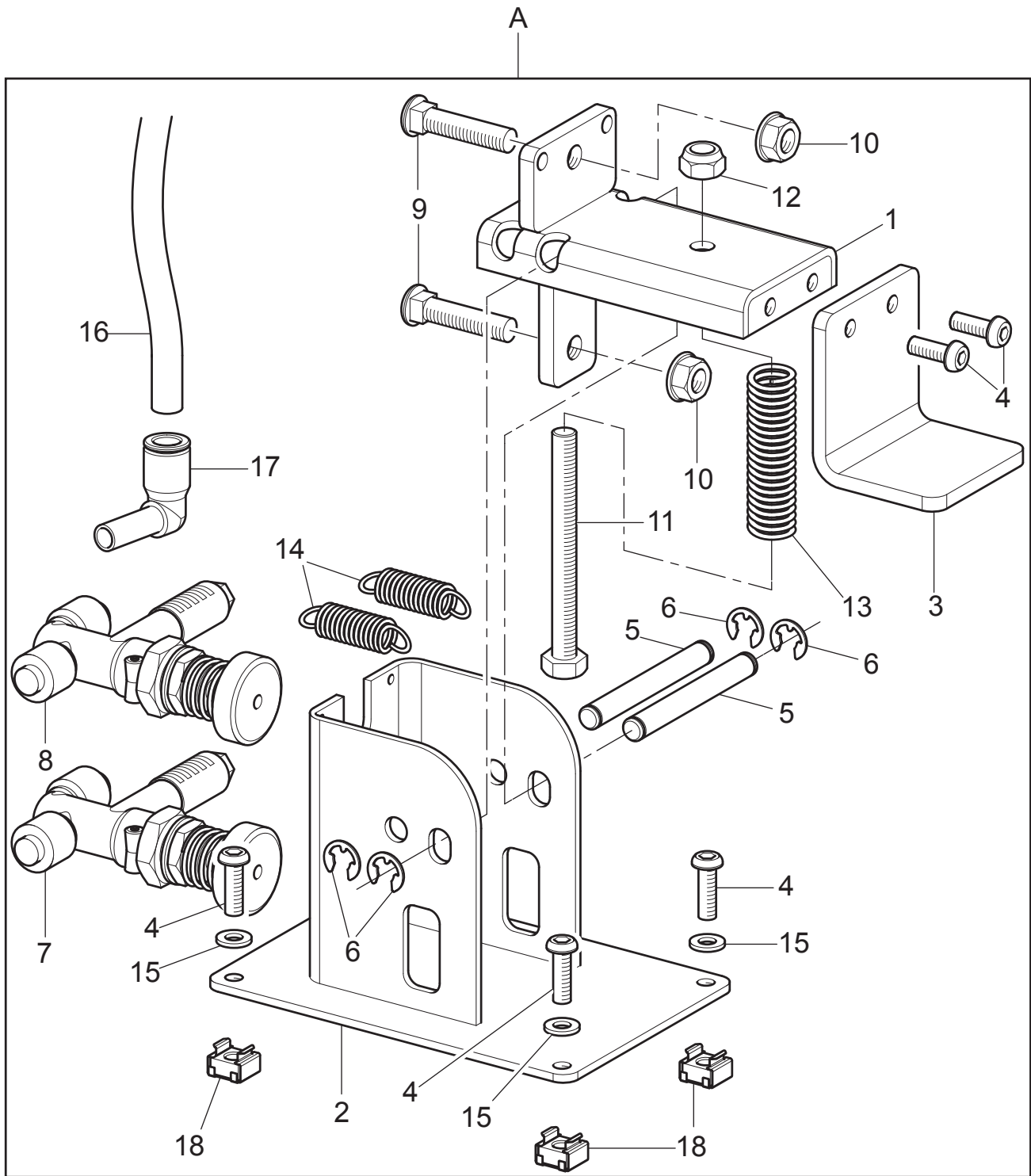
<b>Table Number 13 - Rev. 1</b>		<b>VS730094611</b>		←	→
<b>N°</b>	<b>Code</b>	<b>Description</b>	<b>Description</b>	<b>Descripción</b>	
1	VS730025981Y	10-24 flat chuck assembly			
2	VS140816840Y	Spacer			
3	VS140815322Y	Slide guide			
4	VS730070401	Chuck jaw kit			
5	VS730026341	Fl chuck jaw			
6	VS730027760Y	Block			
7	VS730019310Y	Driving bushing			
8	VS730019190Y	Driven bushing			
9	VS730027770Y	Small pipe			
10	VS730094550	Pneumatic cylinder assembly			
11	VS730023440	Point for jaw			
12	VS730023630Y	Cap			
13	VS730026112Y	Finger protection device			
14	VS730096200Y	10-24 synchronizer			
15	VS730027850Y	10-24 U bolt assembly			
16	VS325107	L rotary union			
17	VS770090190	Standard clamp protections for alloy rims			
18	VS317010	10x8 black rilsan pipe L=700			
19	VS317021	10x8 black elastolan pipe L=3000			
20	VS317038	8x5,5 black Elastolan pipe L=2300			
21	VS599095	Clamp			
22	VS730019290Y	Spacer			
23	VS599505	Clamp			
24	VS403108	Gasket			
25	VS401174	OR			
26	VS321005	Complete piston			
27	VSGU4870	Cylinder gasket kit D.70			
28	VS403108DM	Gasket			
29	VS401076	OR 3256			
30	VS410083	Guide ring			
A	VS730094611	10-24 GT round chuck assembly			



N°	Code	Description	Description	Descripción
1	VS140120420Y	Bracket		
2	VS237021	Shear washer		
3	VS238025	4,3 elastic washer		
4	VS271021	TBEI M6x20 screw		
5	VS325151	Cap		
6	VS140300472Y	Lubrication filter assembly + reduction filter		
7	VS303015	M 1/4-7 rapid coupling		
8	VS325148	T middle union		
9	VS325118	Rotary union		
10	VS399319	Filter unit		
11	VS399320	Lubricator filter unit		
12	VS203160	TE M4x12 screw		
A	VS730095700	Air treatment unit		

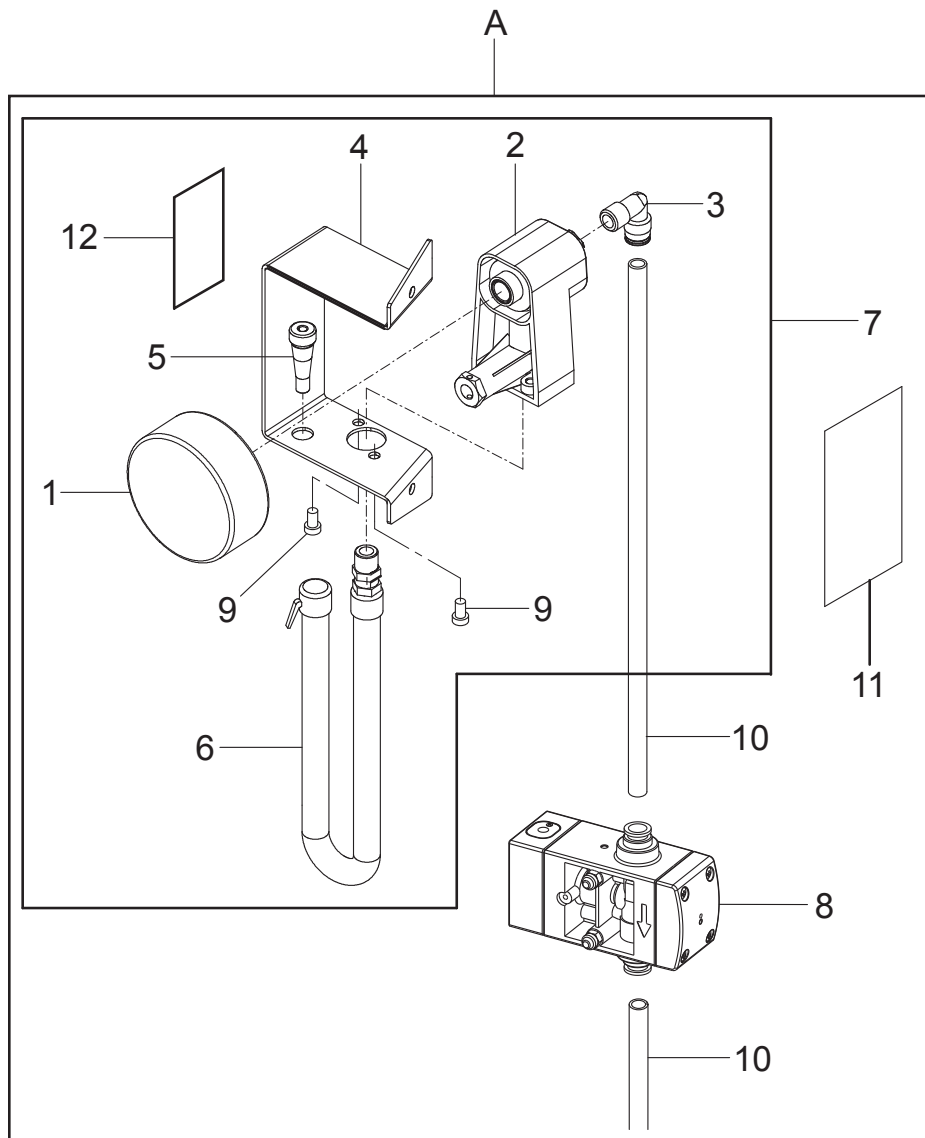


N°	Code	Description	Description	Descripción
1	VS140120420Y	Bracket		
2	VS236025	D. 4,3x9x0,8 washer		
3	VS238025	4,3 elastic washer		
4	VS271021	TBEI M6x20 screw		
5	VS140490762	Pressure reduction filter unit		
6	VS303022	Rubber holder		
7	VS325118	Rotary union		
8	VS325148	T middle union		
9	VS325203	T union		
10	VS399319	Filter unit		
11	VS399320	Lubricator filter unit		
12	VS203160	TE M4x12 screw		
A	VS730095760	Air treatment unit		





N°	Code	Description	Description	Descripción
1	VSB4102100	Inflation pedal		
2	VSB4103200	Pedal support		
3	VSB2729000	Pedal		
4	VS266019	TBEI M6x16 screw		
5	VSB3067000	Inflation pedal board pin		
6	VS299051	D.7 stopper ring		
7	VSB7076000	C Hammer motor valve		
8	VSB7075000	Hammer bead-breaker valve		
9	VSB1453700	TQS M8x45 screw		
10	VS228501	M8 flanged nut		
11	VS201259	TE M8x80 screw		
12	VS228011	M8 self-locking nut		
13	VS299155	MGOH 16x75 spring		
14	VS918006	1,8x12x40,4 TRZ spring		
15	VS238004	6,4 elastic washer		
16	VS317007	8x6 black rilsan pipe L=600		
17	VS325186	8-8 L pneumatic fixed union		
18	VS228250	M6 crated nut		
A	VS140990371	Tubeless inflation pedalboard		



N°	Code	Description	Description	Descripción
1	VS909038	D. 80 pressure gauge		
2	VSB9055001	Man+discharge support		
3	VS325118	Rotary union		
4	VSB1166100	Pressure gauge support		
5	VSB7204000	Tyre valve		
6	VSB1600000	Inflation pipe L=1500		
7	VSB1166900	C angled pressure gauge unit		
8	VS710590670	60PSI inflation unit		
9	VS206188	TCEI M6x12 screw		
10	VS317007	8x6 black rilsan pipe L=3200		
11	VS999911870	Headphones plate		
12	VSB2170000	Max inflation pressure rating plate		
A	VS140790205	Inflation unit		



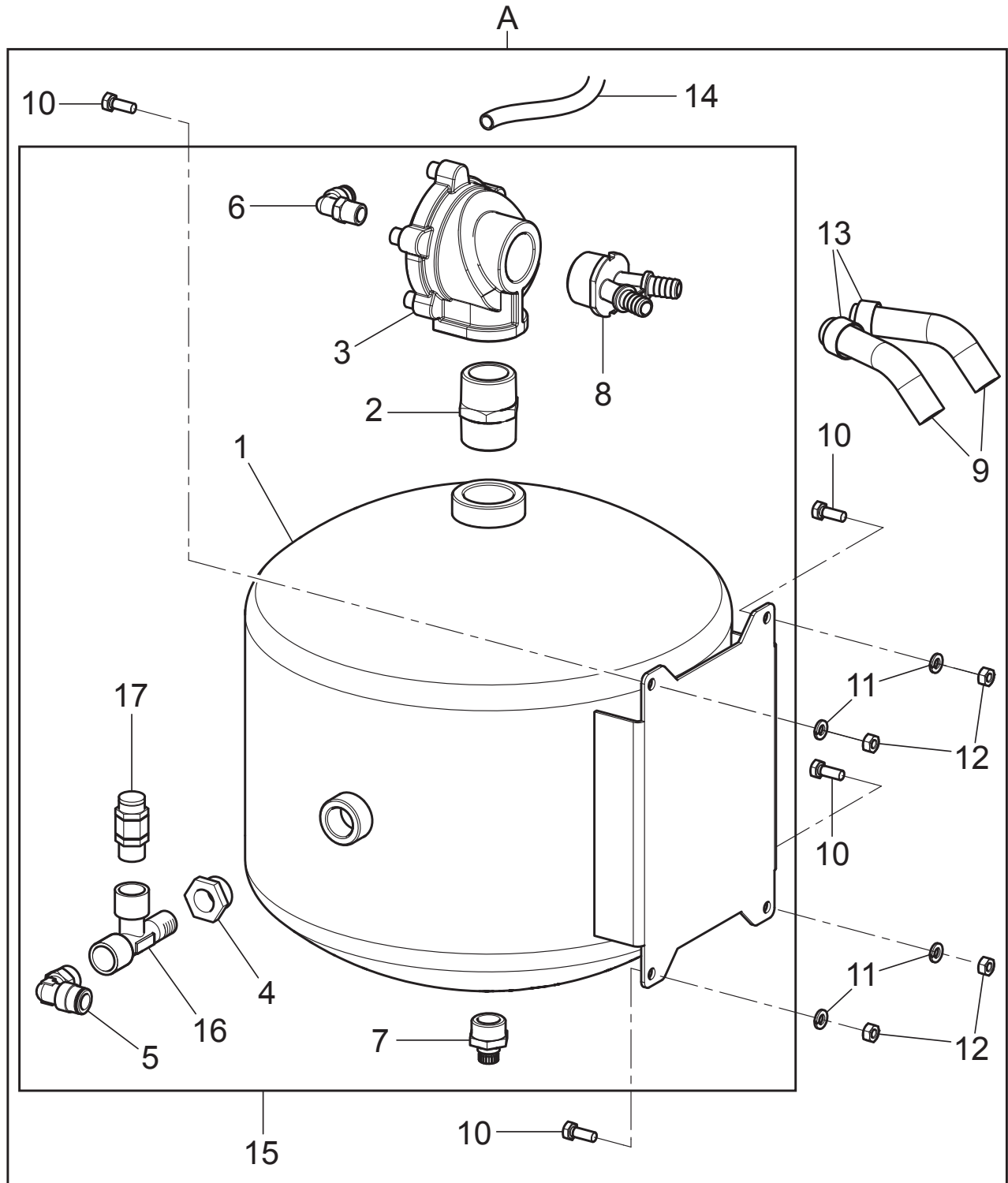
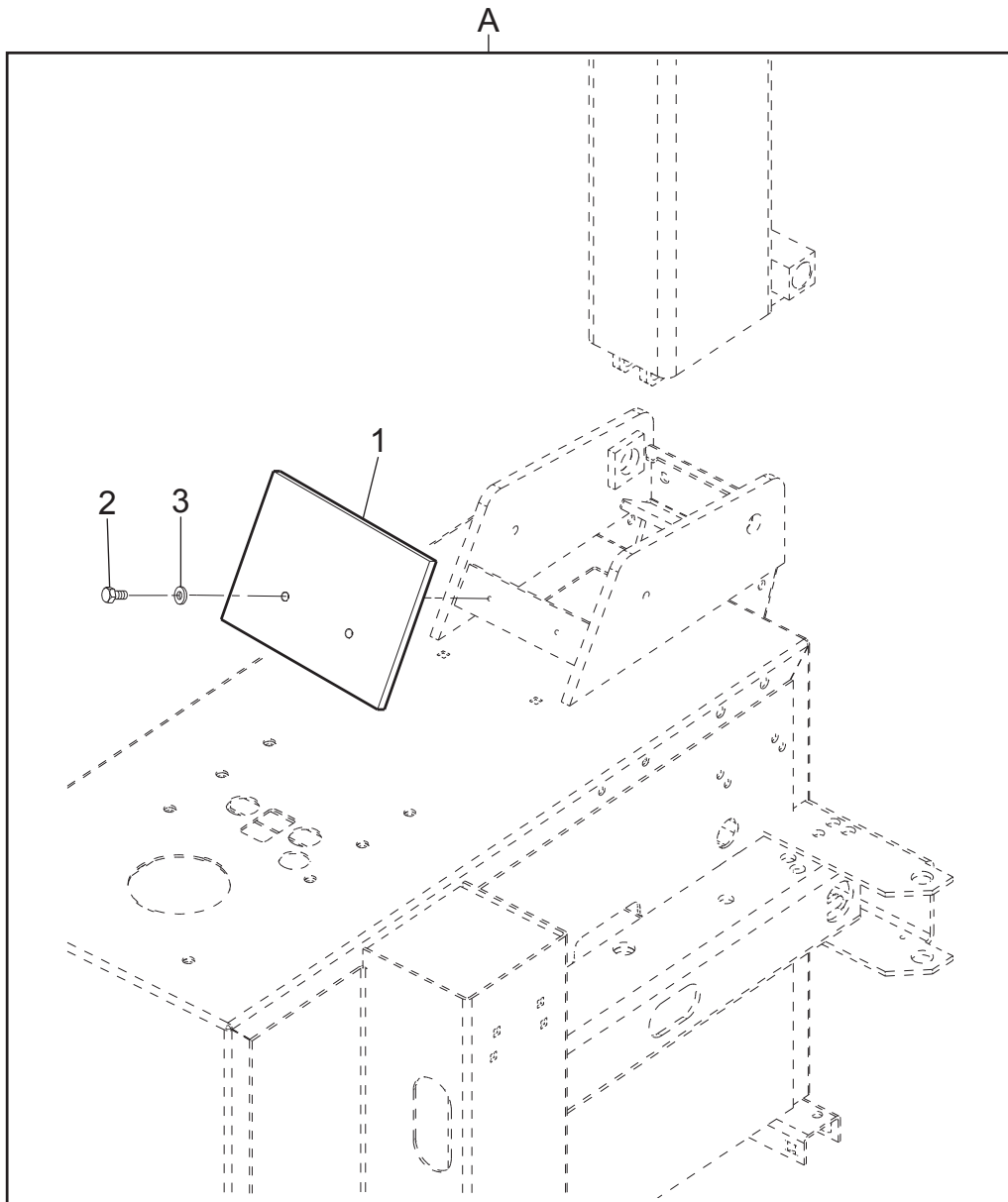
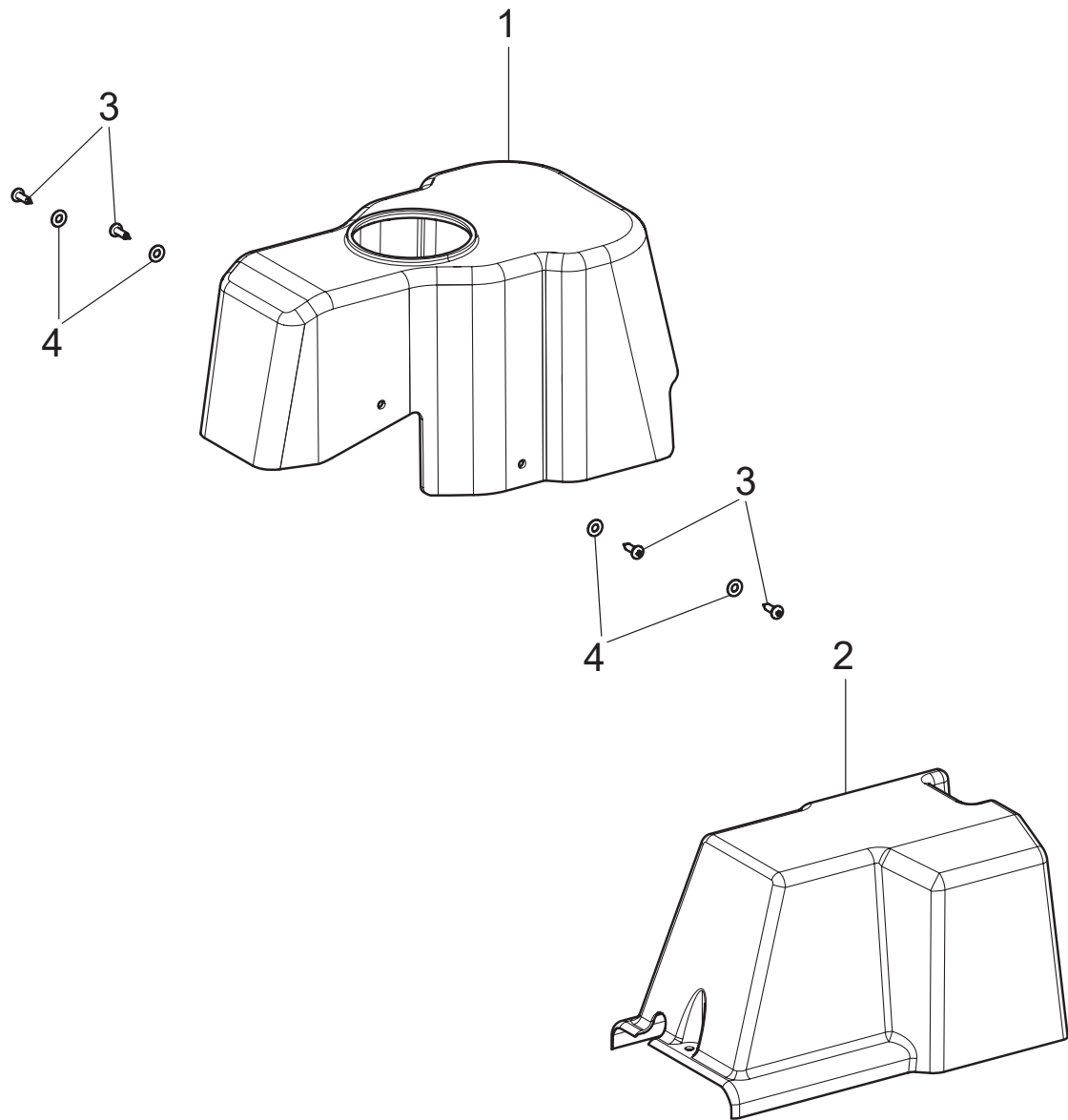


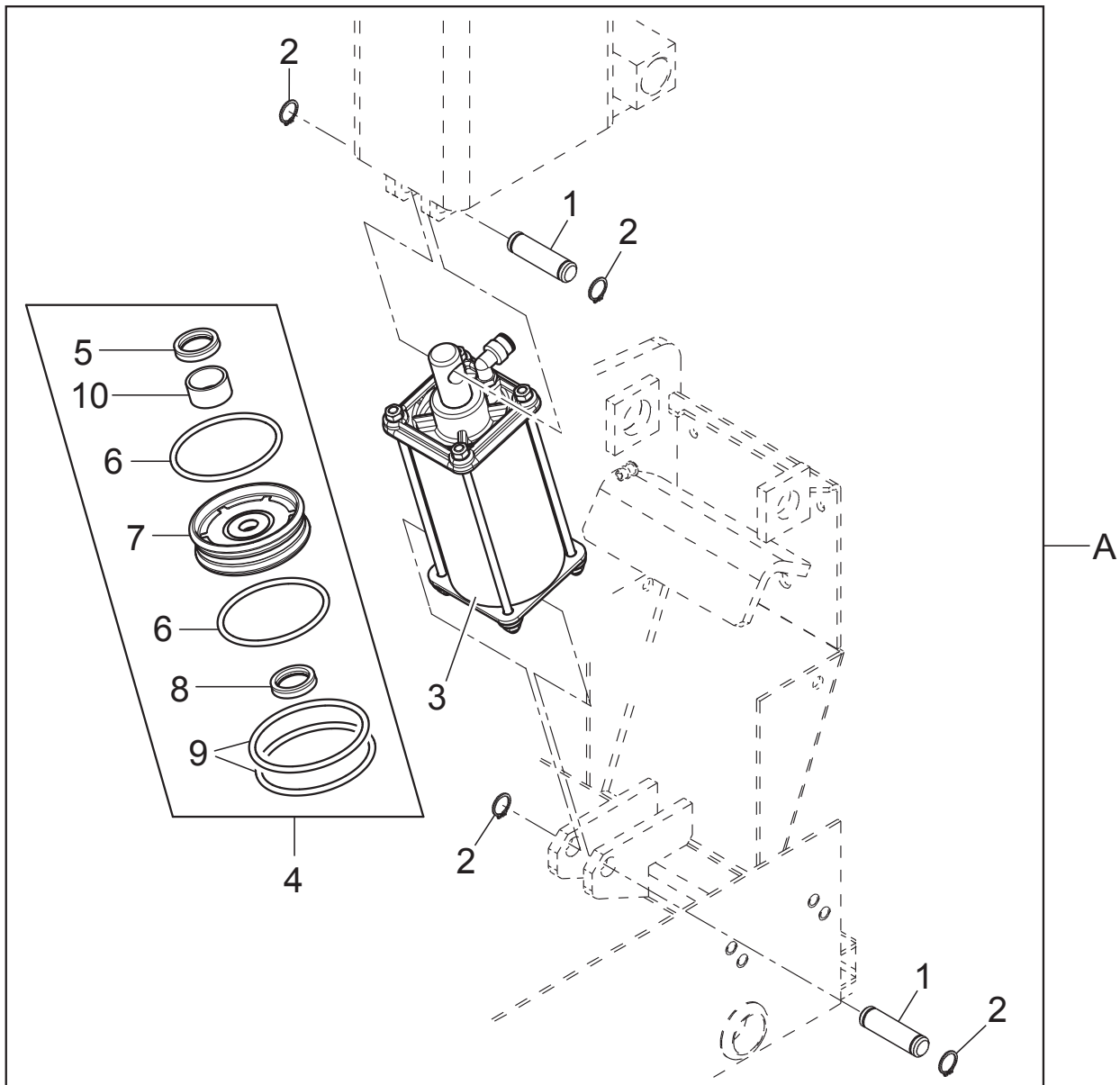
Table Number 17 - Rev. 0		VS730092430		▶	▶
N°	Code	Description	Description	Descripción	
1	VS790010121	Tank			
2	VS81202700	M-M1" nipple union			
3	VS309095	Blow valve			
4	VS533016	Reduction			
5	VS325107	Union			
6	VS325031	Rotary union			
7	VS81175900	1/2" Release cock			
8	VS730016760	Y union			
9	VS318011	Screened pipe L= 700			
10	VS203019	TE M6x16 screw			
11	VS238004	6,4 elastic washer			
12	VS224007	M6 middle nut			
13	VS319012	Clamp			
14	VS317010	10x8 black rilsan pipe L= 1000			
15	VS730092440	Tank PRMTG			
16	VS81146000	1/4" MFF T union			
17	VS81505000	Safety valve			
A	VS730092430	Air reservoir assembly			



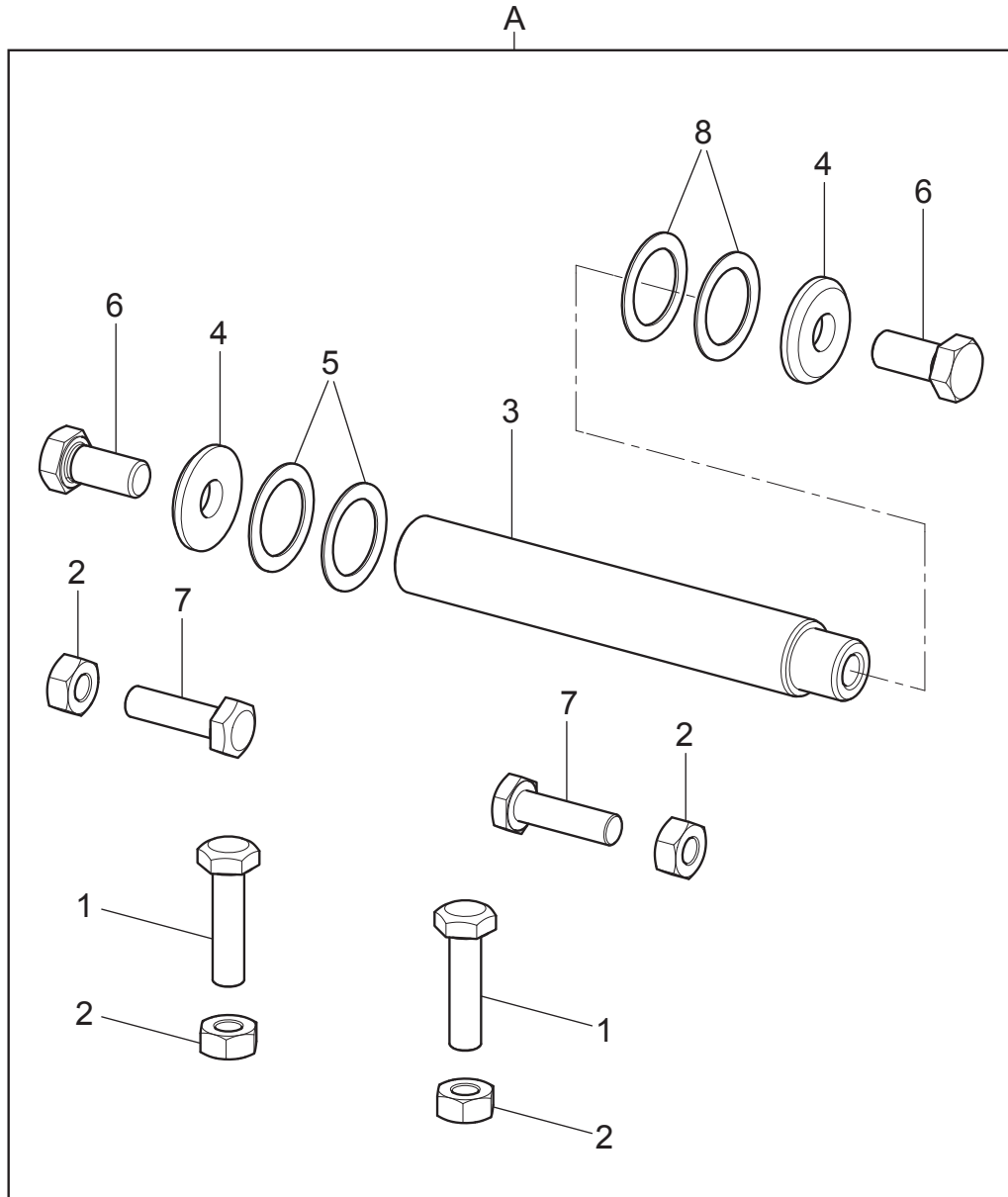
N°	Code	Description	Description	Descripción
1	VS140301920Y	Pile base covering		
2	VS203146	TE M5x6 screw		
3	VS237010	5x20x1,5 washer		
A	VS140390580	Post base protection unit		



N°	Code	Description	Description	Descripción
1	VS730021540	Front covering		
2	VS140301702	Guard		
3	VS220063	TCB M4,2x13 screw		
4	VS236025	D. 4,3x9x0,8 washer		
A	VS140390513	Superior guard unit		



N°	Code	Description	Description	Descripción
1	VS14030131Y	Pin		
2	VS243006	Ring 14		
3	VS730091250	D.70 column turnover cylinder		
4	VSGU4870	Cylinder gasket kit D.70		
5	VS403108	Gasket		
6	VS401174	OR		
7	VS321005	Complete piston		
8	VS403108DM	Gasket		
9	VS401076	OR 3256		
10	VS410083	Guide ring		
A	VS730091270	Tilting post piston unit		



N°	Code	Description	Description	Descripción
1	VS730012330	Retaining screw M10x40		
2	VS224011	M10 middle hexagonal nut		
3	VS140315211Y	Pin		
4	VS140315391Y	Spacer		
5	VS237501	Thickness washer		
6	VS203186	TE M12x25 screw		
7	VS730015010	Screw		
8	VS237511	Thickness washer		
A	VS140392740	Tilting post fulcrum unit		

**Installer:** Please return this booklet to literature package, and give it to the owner/operator.

***Thank You***

Trained Operators and Regular Maintenance Ensures Satisfactory Performance of Your Wheel Service Equipment.

Contact Your Nearest Authorized Rotary Wheel Service Equipment Parts Distributor for Genuine Replacement Parts. See Literature Package for Parts Breakdown.

**Rotary World Headquarters**  
2700 Lanier Drive  
Madison, IN 47250, USA  
www.rotarylif.com

**North America Contact Information**

Tech. Support:  
p 800.445.5438  
f 800.578.5438  
e userlink@rotarylif.com  
Sales: p 800.640.5438  
f 800.578.5438  
e userlink@rotarylif.com

**World Wide Contact Information**

World Headquarters/USA: 1.812.273.1622  
Canada: 1.905.812.9920  
European Headquarters/Germany: +49.771.9233.0  
United Kingdom: +44.178.747.7711  
Australasia: +60.3.7660.0285  
Latin America / Caribbean: +54.3488.431.608  
Middle East / Northern Africa: +49.771.9233.0

**© Vehicle Service Group™**

Printed in U.S.A., All Rights Reserved. Unless otherwise indicated, ROTARY, and all other trademarks are property of Dover Corporation and its affiliates.

