

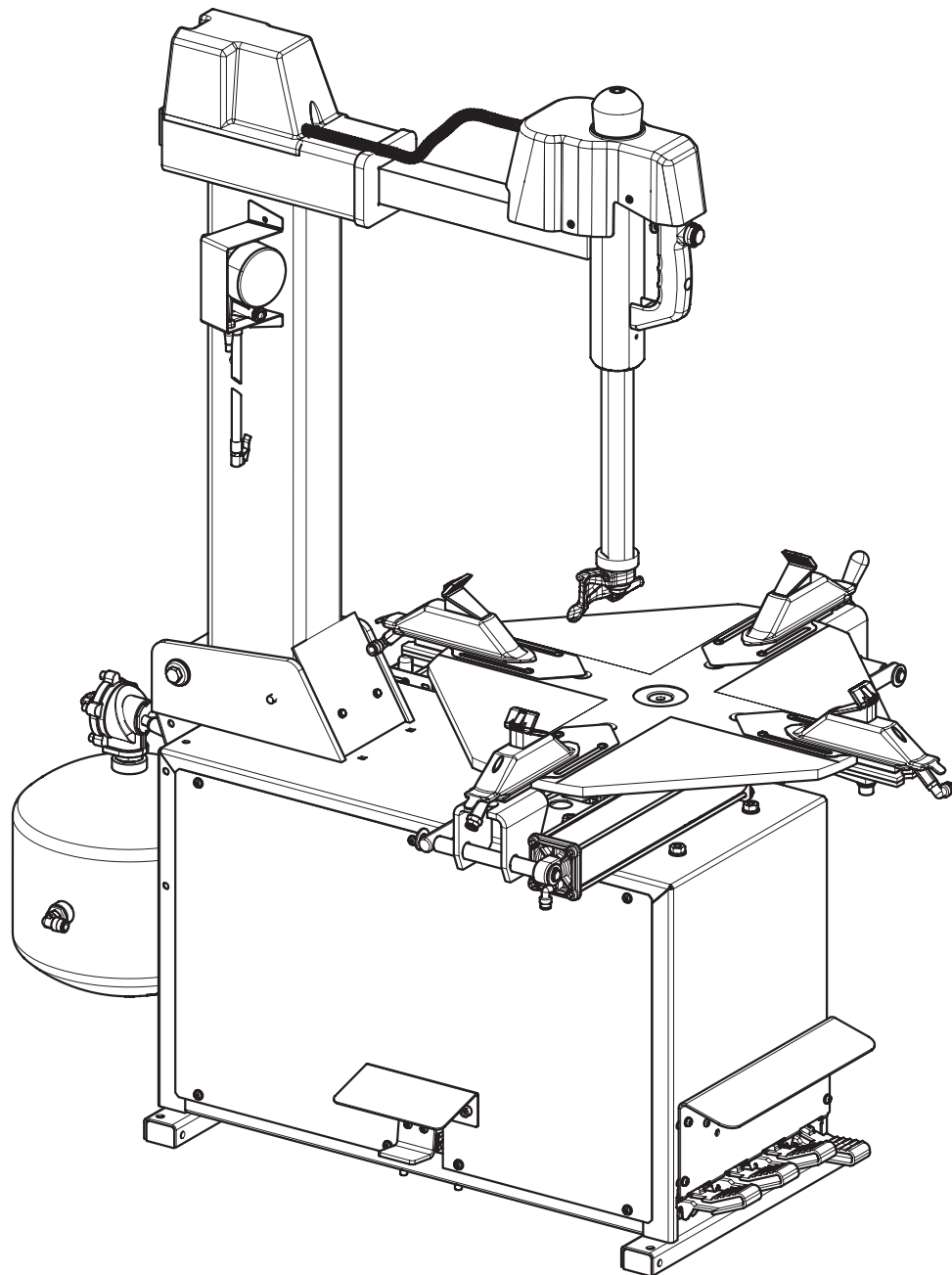

R141I Series Tyre Changer



OPERATION & MAINTENANCE MANUAL

IMPORTANT Any damage caused by failure to follow the instructions in this manual or improper machine use shall relieve the manufacturer of all liability.

© Month And Date by Vehicle Service Group. All rights reserved. CO

R141I-SMS-1
Rev. a. 01 (05/2023)

SUMMARY

GENERAL DESCRIPTION _____	4	11.0 CONTROLS _____	18
SYMBOLS USED IN THE MANUAL _____	5	11.1 4 pedals control unit _____	18
INFORMATION PLATE LOCATION TABLE _____	6	11.2 Inflation pedal (on demand) _____	19
1.0 GENERAL INTRODUCTION _____	8	11.3 Additional pedal for devices with tubeless inflation _____	19
1.1 Introduction _____	8	11.4 Post unit handle manual adjustment _____	19
2.0 INTENDED USE _____	8	12.0 USING THE MACHINE _____	20
2.1 Training of personnel _____	8	12.1 Precaution measures during tyre removal and fitting _____	20
3.0 SAFETY DEVICES _____	9	12.2 Preliminary operations - Preparing the wheel _____	20
3.1 Residual risks _____	9	12.3 Bead breaking _____	20
4.0 IMPORTANT SAFETY INSTRUCTIONS _____	10	12.4 Wheel clamping on the chuck _____	21
4.1 General safety rules _____	10	12.5 Demounting _____	22
5.0 PACKING AND MOBILIZATION FOR TRANSPORT _____	11	12.6 Setting the tool for tyre fitting and removal _____	23
6.0 UNPACKING _____	12	12.6.1 Setting neck travel _____	24
7.0 MOBILIZATION _____	12	12.6.2 Setting the tool for tyre fitting and removal _____	24
8.0 WORKING ENVIRONMENT CONDITIONS _____	13	12.7 Mounting the tyre _____	25
8.1 Working position _____	13	12.8 Tyre inflation _____	26
8.2 Installation space _____	13	12.8.1 Tyre inflation with pressure gauge (on demand) _____	27
8.3 Lighting _____	13	12.8.2 Tyre inflation device with Tubeless inflation unit _____	27
9.0 ANCHORING SYSTEM _____	14	13.0 ROUTINE MAINTENANCE _____	27
10.0 ASSEMBLY AND PREPARATION FOR USE _____	14	13.1 Lubricants _____	29
10.1 Fixtures contained in the packing _____	14	14.0 TROUBLESHOOTING TABLE _____	30
10.2 Assembly procedures _____	14	15.0 TECHNICAL DATA _____	31
10.3 Post unit assembly _____	15	15.1 Technical electrical data _____	31
10.4 Bead breaker arm mounting _____	15	15.2 Technical mechanical data _____	31
10.5 Tubeless inflation mounting (only for versions with tubeless inflation) _____	16	15.3 Dimensions _____	32
10.6 Electrical connections _____	17	16.0 STORING _____	33
10.7 Check of motor rotation direction _____	18	17.0 SCRAPPING _____	33
10.8 Air connection _____	18	18.0 REGISTRATION PLATE DATA _____	33
10.9 Checks _____	18		

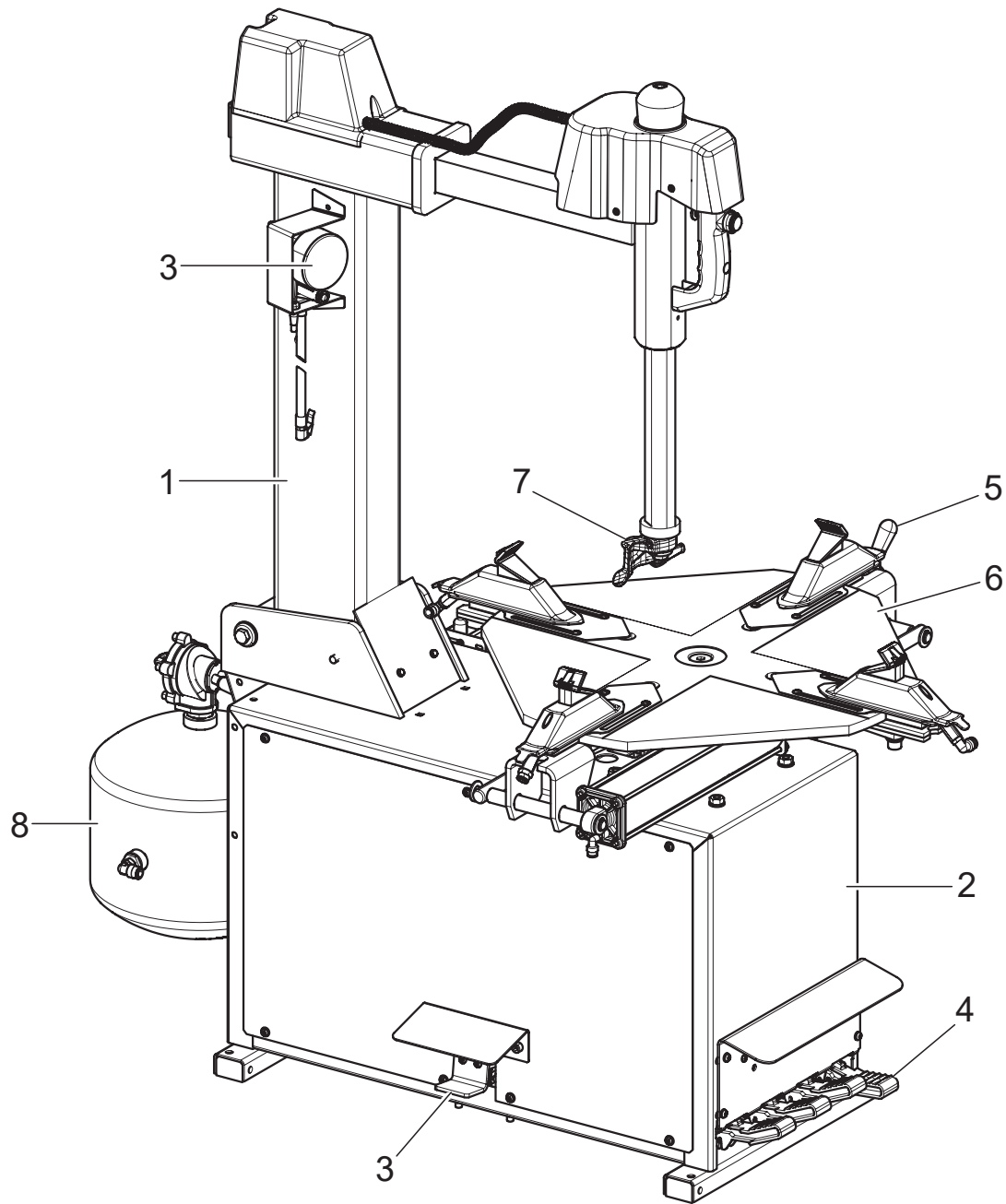

Model	Basic model	Power supply	Rotation speed	Clamping system	Tubeless inflation
RC141I	RC141SD.24I	240/1/50	Adjustable	Jaws	X
RC141I	RC141SQ.24I	400/3/50	2		X









KEY

- 1 – Post unit
- 2 – Machine body
- 3 – Inflation unit (only for versions with tubeless inflation)
- 4 – Pedalboard unit
- 5 – Bead breaker unit
- 6 – Complete chuck
- 7 - Tool
- 8 – Tank (only for versions with tubeless inflation)

SYMBOLS USED IN THE MANUAL

Symbols	Description
	Read instruction manual.
	Wear work gloves.
	Wear work shoes.
	Wear safety goggles.
	Mandatory. Operations or jobs to be performed compulsorily.
	Danger! Be particularly careful.
	Warning. Be particularly careful (possible material damages).

Symbols	Description
	Move with fork lift truck or pallet truck.
	Lift from above.
	Note. Indication and/or useful information.
	Technical assistance necessary. Do not perform any intervention.
	Caution: hanging loads.
	Hands crushing danger.

INFORMATION PLATE LOCATION TABLE

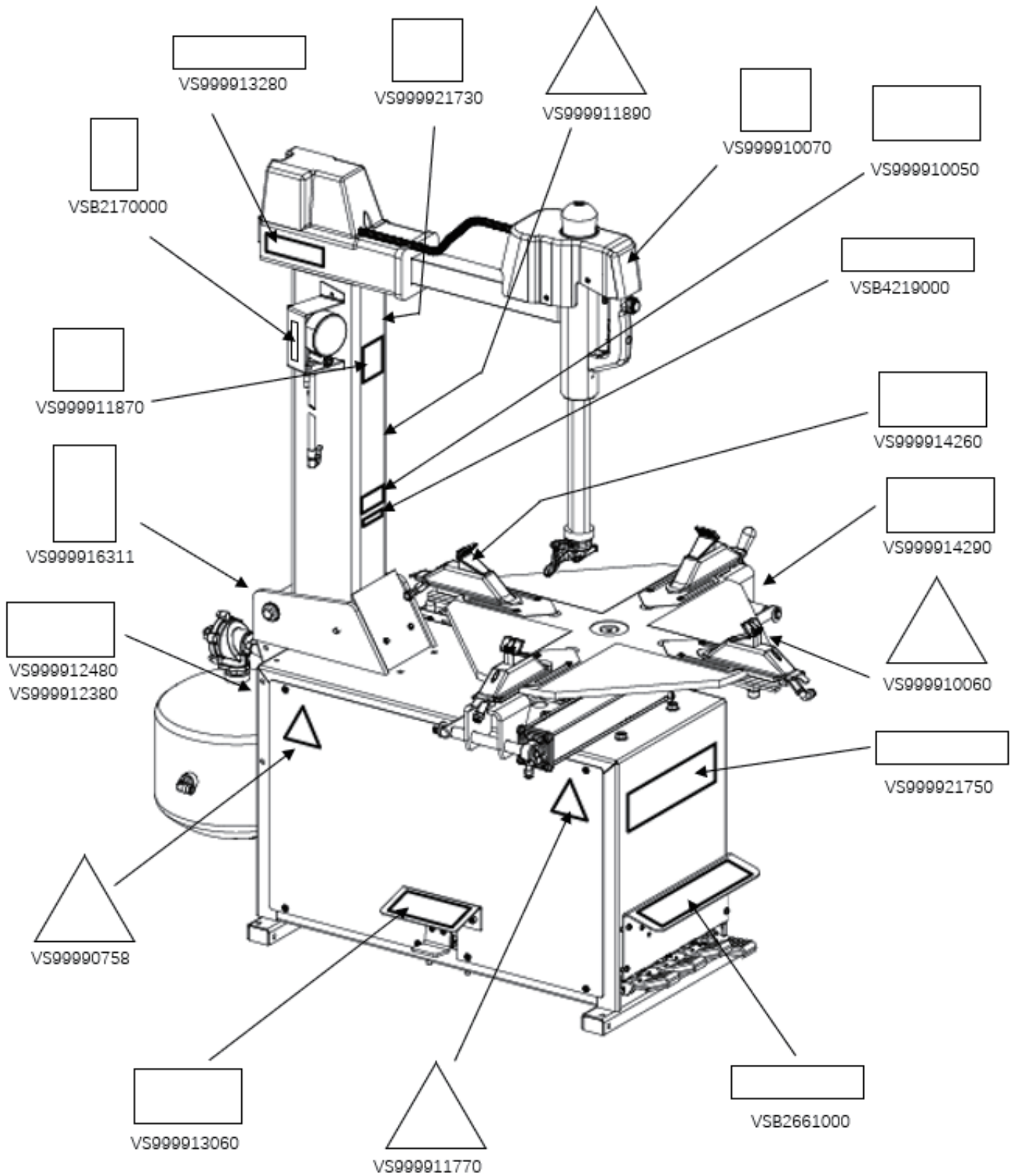

Code numbers of plates

VSB2170000	Max. inflation pressure rating plate (only for versions with tubeless inflation)
VSB2661000	4-pedal symbol plate
VSB4219000	Rotation indicating plate
VSB4244000	Rotating parts danger plate
VS99990758	Electric shock danger plate
VS999910050	Protection device use plate
VS999910060	Bead breaker danger plate
VS999910070	Head danger indicating plate
VS999911870	Headphones plate (only for versions with tubeless inflation)
VS999911890	Bursting tyre hazard plate
VS999912380	400V 50Hz 3Ph voltage plate (for 3-Ph versions only)
VS999912460	Supply pressure indicating plate
VS999912480	240/50/1 voltage plate (for 1-phase version only)
VS999913280	Post tilting plate
VS999914290	Serial number plate
VS999916311	Rubbish skip plate
VS999921730	Rotary plate
VS99991300	Inflation plate
VS999921750	Rotary "R141I" plate



IF ONE OR MORE PLATES DISAPPEAR FROM THE MACHINE OR BECOMES DIFFICULT TO READ. REPLACE IT AND QUOTE ITS/THEIR CODE NUMBER/S WHEN REORDERING.



SOME OF THE PICTURES PRESENT IN THIS MANUAL HAVE BEEN OBTAINED FROM PICTURES OF PROTOTYPES, THEREFORE THE STANDARD PRODUCTION MACHINES AND ACCESSORIES CAN BE DIFFERENT IN SOME COMPONENTS.

1.0 GENERAL INTRODUCTION

This manual is an integral part of the product and must be retained for the whole operating life of the machine.

Carefully study the warnings and instructions contained in this manual. It contains important instructions regarding **FUNCTIONING**, **SAFE USE** and **MAINTENANCE**.



KEEP THE MANUAL IN A KNOWN, EASILY ACCESSIBLE PLACE FOR ALL ACCESSORY OPERATORS TO CONSULT IT WHENEVER IN DOUBT.



THE MANUFACTURER DISCLAIMS ALL RESPONSIBILITY FOR ANY DAMAGE OCCURRED WHEN THE INDICATIONS GIVEN IN THIS MANUAL ARE NOT RESPECTED: AS A MATTER OF FACT, THE NON-COMPLIANCE WITH SUCH INDICATIONS MIGHT LEAD TO EVEN SERIOUS DANGERS.

1.1 Introduction

Thank you for preferring this electro-hydraulic tyre changer. We feel sure you will not regret your decision.

This machine has been designed for use in professional workshops and in particular it stands out for its reliability and easy, safe and rapid operation: with just a small degree of maintenance and care, this tyre changer will give you many years of trouble-free service and lots of satisfaction.

2.0 INTENDED USE

The machines described in this manual, and their different versions, are tyre-changers for car tyres projected to be used exclusively for the mounting, demounting, and inflation of wheels with dimension values mentioned in "Technical specifications" chapter.



THIS ACCESSORY MUST ONLY BE USED FOR THE PURPOSE FOR WHICH IT IS SPECIFICALLY DESIGNED. ANY OTHER USE IS CONSIDERED IMPROPER AND THEREFORE UNACCEPTABLE.



THE MANUFACTURER CANNOT BE HELD RESPONSIBLE FOR ANY DAMAGE CAUSED BY IMPROPER, ERRONEOUS, OR UNACCEPTABLE USE.

2.1 Training of personnel

The machine may be operated only by suitably trained and authorized personnel.

Given the complexity of the operations necessary to manage the machine and to carry out the operations safely and efficiently, the personnel must be trained in such a way that they learn all the information necessary to operate the machine as intended by the manufacturer.



A CAREFUL READING OF THIS INSTRUCTION MANUAL FOR USE AND MAINTENANCE AND A SHORT PERIOD OF TRAINING WITH SKILLED PERSONNEL CAN BE AN ENOUGH PREVENTIVE PREPARATION.

3.0 SAFETY DEVICES

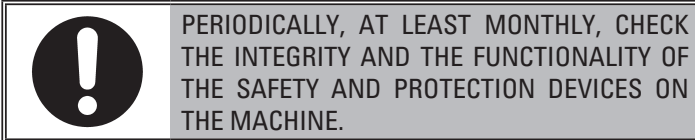

All the machines are equipped with:

- Fixed guards.
The machine is fitted with a number of fixed guards intended to prevent potential crushing, cutting and compression risks.
- “Operator attending” controls (immediate stop by releasing control) for: chuck rotation, bead breaker vane motion, inflating; other drives such as rim clamping on chuck, demounting/mounting tool clamping cannot be of the operator-attending type, seen their function. In these cases safety is guaranteed by compliance with indications or precautions on machine residual risks (warning plates) also mentioned in the user’s guide.

Moreover, all the machines that can be used for inflating tyres are equipped with the following elements:

- pressure gauge for tyre pressure reading, EC-certified and in compliance with 86/217/EEC Standard;
- max. pressure valve fitted on compressed air reservoir (preset – see pneumatic diagram) in compliance with 87/404/EEC Standard;
- Non-adjustable (balancing valve) pressure limiter.

This allows inflation of tyres in reasonable safety. Inflation of tyres to over $4,2 \pm 0,2$ bar (60 PSI) is not allowed.

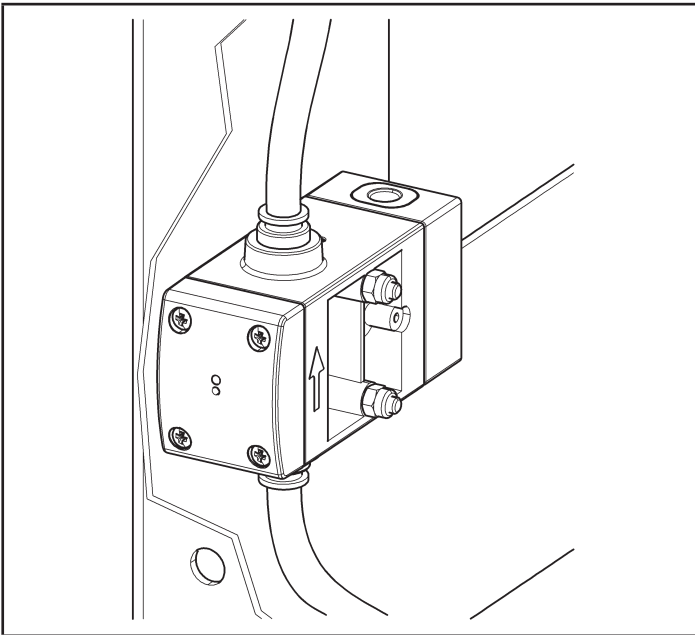

- 12bar safety valve on tank (only for versions with tubeless inflation).

The safety valve (see the following figure ref. 1) avoids that the inflation tank is under a pressure above 12 bar.

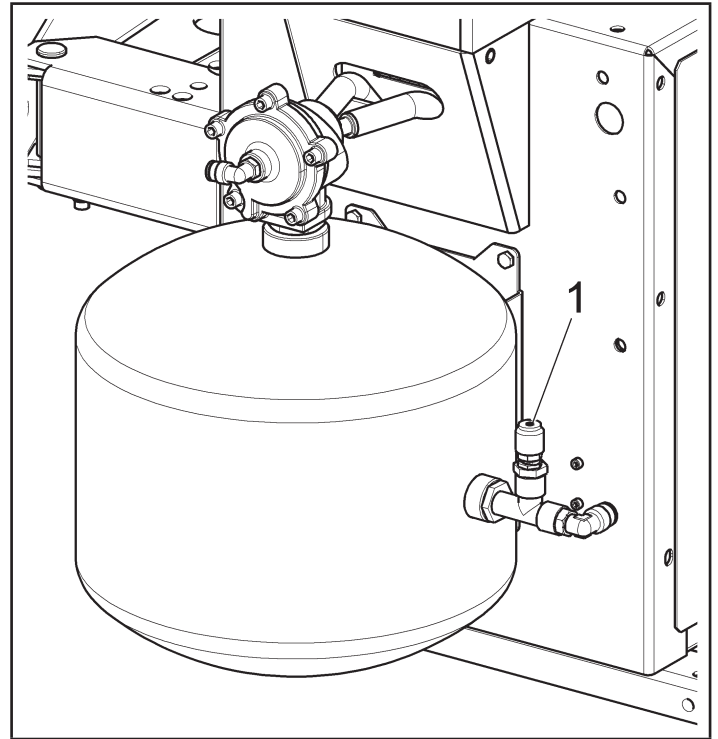

3.1 Residual risks

The machine was subjected to a complete analysis of risks according to reference standard EN ISO 12100.

Risks are as reduced as possible in relation with technology and product functionality.

This manual stresses possible residual risks, also highlighted in pictograms on the present manual and adhesive warning signals placed on the machine: their location is represented in “PLATE LOCATION ON MACHINE INFORMATION TABLE” on page 5.

4.0 IMPORTANT SAFETY INSTRUCTIONS

When using your garage equipment, basic safety precautions should always be followed, including the following:

1. Read all instructions.
2. Care must be taken as burns can occur from touching hot parts.
3. Do not operate equipment with a damaged cord or if the equipment has been dropped or damaged – until it has been examined by a qualified service person.
4. Do not let a cord hang over the edge of the table, bench, or counter or come in contact with hot manifolds or moving fan blades.
5. If an extension cord is necessary, a cord with a current rating equal to or more than that of the equipment should be used. Cords rated for less current than the equipment may overheat. Care should be taken to arrange the cord so that it will not be tripped over or pulled.
6. Always unplug equipment from electrical outlet when not in use. Never use the cord to pull the plug from the outlet. Grasp plug and pull to disconnect.
7. Let equipment cool completely before putting away. Loop cord loosely around equipment when storing.
8. To reduce the risk of fire, do not operate equipment in the vicinity of open containers of flammable liquids (gasoline).
9. Adequate ventilation should be provided when working on operating internal combustion engines.
10. Keep hair, loose clothing, fingers, and all parts of body away from moving parts.
11. To reduce the risk of electric shock, do not use on wet surfaces or expose to rain.
12. Use only as described in this manual. Use only manufacturer's recommended attachments.
13. ALWAYS WEAR SAFETY GLASSES. Everyday eyeglasses only have impact resistant lenses, they are not safety glasses.
14. To reduce the risk of injury, close supervision is necessary when this product will be used around children. (Pertains to cabinets only.)
15. To reduce the risk of injury, never overload the drawers or shelves. Refer to loading instructions.
16. To reduce the risk of electric shock or fire, never overload receptacles. Refer to markings for the proper load on receptacles.

SAVE THESE INSTRUCTIONS

4.1 General safety rules



- Any tampering with or modification to the machine not previously authorized by the manufacturer exempts the latter from all responsibility for damage caused by or derived from said actions.
- Removing of or tampering with the safety devices or with the warning signals placed on the machine leads to serious dangers and represents a transgression of European safety rules.
- The machine may be used only in areas free from the danger of explosion or fire.
- The use of only original accessories and spare parts is advised. Our machine is designed to function only with original accessories.
- The installation must be performed by qualified personnel in full compliance with the instructions given below.
- Ensure that there are no dangerous situations during the machine operating manoeuvres. Immediately stop the machine if it malfunctions and contact the assistance service of an authorized dealer.
- In emergency situations and before carrying out any maintenance or repairs, disconnect all supplies to the machine by using the main switch.
- Ensure that the work area around the machine is free of potentially dangerous objects and that there is no oil since this could damage the tyre. Oil on the floor is also a potential danger for the operator.



THE MANUFACTURER DENIES ANY RESPONSIBILITY IN CASE OF DAMAGES CAUSED BY UNAUTHORIZED MODIFICATIONS OR BY THE USE OF NON ORIGINAL COMPONENTS OR EQUIPMENT.



OPERATORS MUST WEAR SUITABLE WORK CLOTHES, PROTECTIVE GLASSES AND GLOVES, AGAINST THE DANGER FROM THE SPRAYING OF DANGEROUS DUST, AND POSSIBLY LOWER BACK SUPPORTS FOR THE LIFTING OF HEAVY PARTS. DANGLING OBJECTS LIKE BRACELETS MUST NOT BE WORN, AND LONG HAIR MUST BE TIED UP. FOOTWEAR SHOULD BE ADEQUATE FOR THE TYPE OF OPERATIONS TO BE CARRIED OUT.

- The machine handles and operating grips must be kept clean and free from oil.
- The workshop must be kept clean, dry and not exposed to atmospheric agents. Make sure that the working premises are properly lit.

The machine can be operated by a single operator. Unauthorised personnel must remain outside the working area, as shown in Figure 4.

Avoid any hazardous situations. Do not use air-operated or electrical equipment when the shop is damp or the floor slippery and do not expose such tools to atmospheric agents.

- During inflation do not lean on the tyre or stand on it; when beading in the tyre, keep hands away from tyre and rim edge.
- During inflation always stay to the side of the machine and never in front of it.
- When operating and servicing this machine, carefully follow all applicable safety and accident-prevention precautions. The machine must not be operated by untrained personnel.

	<p>IN CASE OF A CHANGE SUPPLY FAILURE (WHETHER ELECTRICITY OR COMPRESSED AIR), MOVE THE PEDALS TO THE NEUTRAL POSITION.</p>
---	--

5.0 PACKING AND MOBILIZATION FOR TRANSPORT

			
<p>HAVE THE MACHINE HANDLED BY SKILLED PERSONNEL ONLY. THE LIFTING EQUIPMENT MUST WITHSTAND A MINIMUM RATED LOAD EQUAL TO THE WEIGHT OF THE PACKED MACHINE (see paragraph "TECHNICAL SPECIFICATIONS").</p>			

The machine is packed partially assembled. Movement must be by pallet-lift or fork-lift trolley. The fork lifting points are indicated on the packing.

Fig. 2

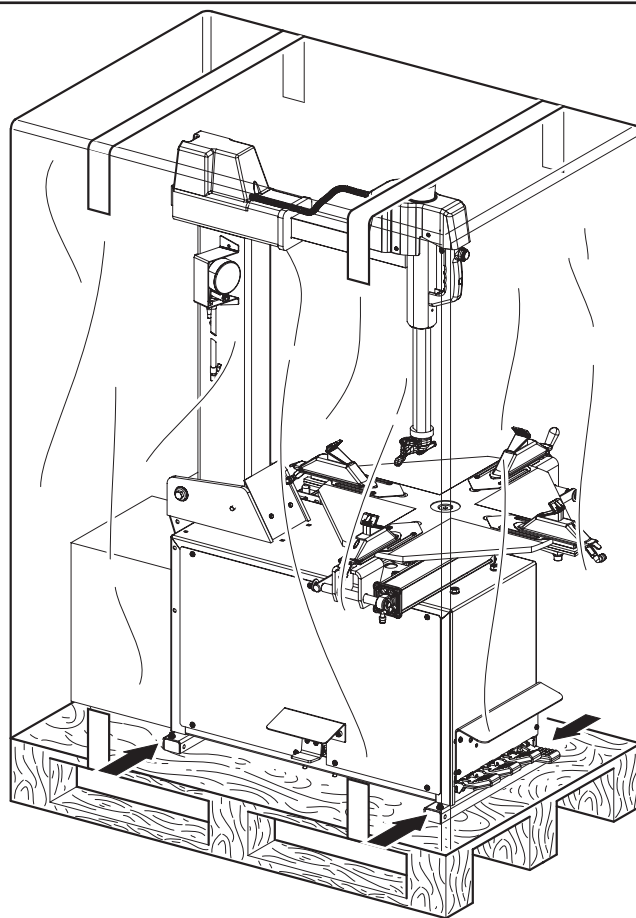

6.0 UNPACKING

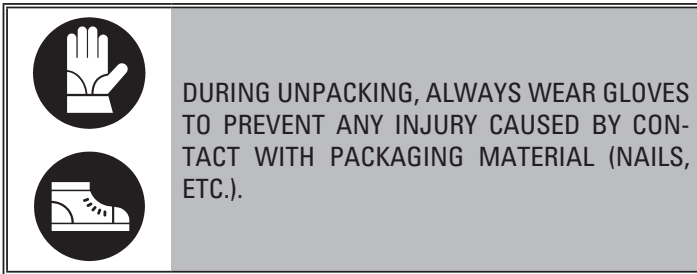

The cardboard box is supported with plastic strapping. Cut the strapping with suitable scissors. Use a small knife to cut along the lateral axis of the box and open it like a fan.

It is also possible to unnailed the cardboard box from the pallet it is fixed to. After removing the packing, and in the case of the machine packed fully assembled, check that the machine is complete and that there is no visible damage.

If in doubt do not use the machine and refer to professionally qualified personnel (to the seller).

The packing (plastic bags, expanded polystyrene, nails, screws, timber, etc.) should not be left within reach of children since it is potentially dangerous. These materials should be deposited in the relevant collection points if they are pollutants or non biodegradable.

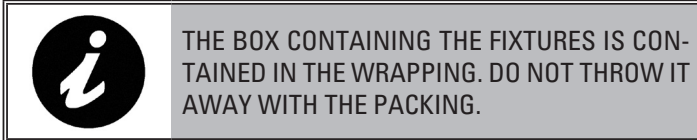

7.0 MOBILIZATION

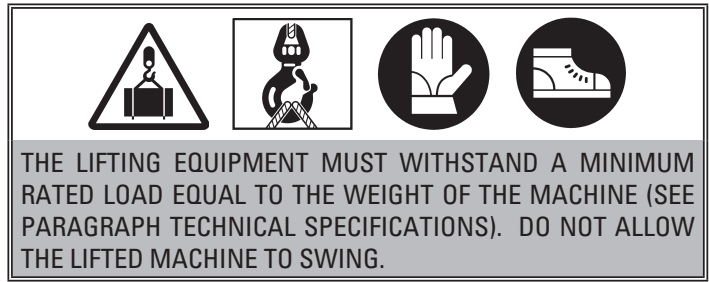

During the machine handling from the unpacking position to the installation one, follow the instructions listed below.

- Protect the exposed corners with suitable material (Pluribol/ cardboard).
- Do not use metallic cables for lifting.
- Make sure that the power supply is not connected.
- Sling with belts long at least 100 cm and with a capacity load greater than 1000 kg (see Fig. 3).

Fig. 3

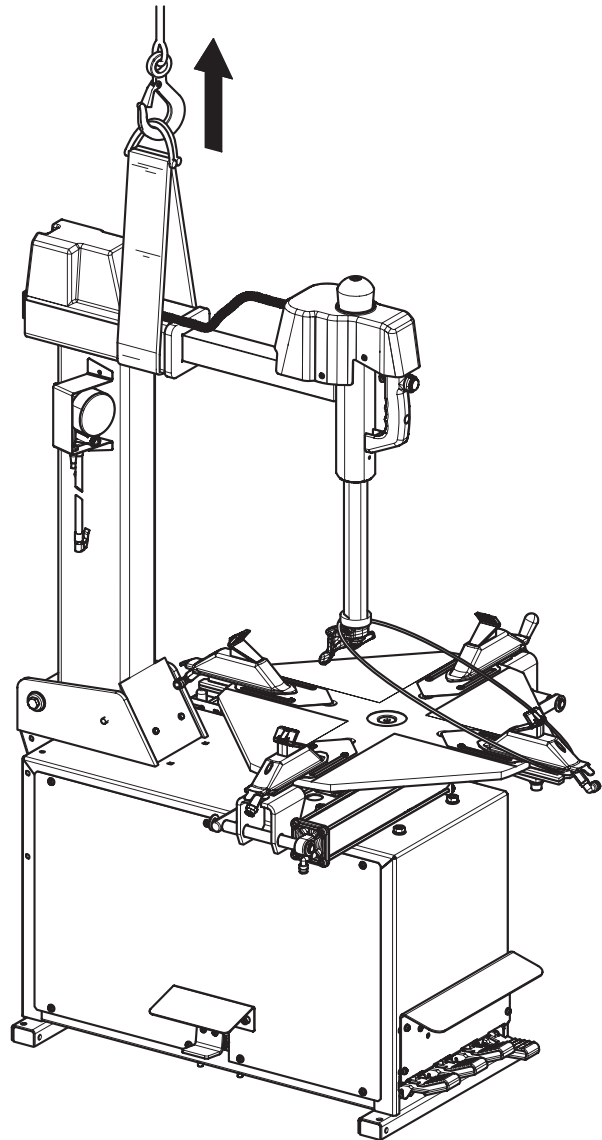

8.0 WORKING ENVIRONMENT CONDITIONS

The machine must be operated under proper conditions as follows:

- temperature: 0° + 55° C
- relative humidity: 30 - 95% (dew-free)
- atmospheric pressure: 860 - 1060 hPa (mbar).

The use of the machine in ambient conditions other than those specified above is only allowed after prior agreement with and approval of the manufacturer.

8.1 Working position

In Figure 4 it is possible to identify working positions A and B. Position A is the main position for wheel fitting and removal with the chuck, while position B is ideal to follow wheel bead breaking operations.

Working in these positions allows better precision and speed during operating phases as well as greater safety for the operator.

8.2 Installation space

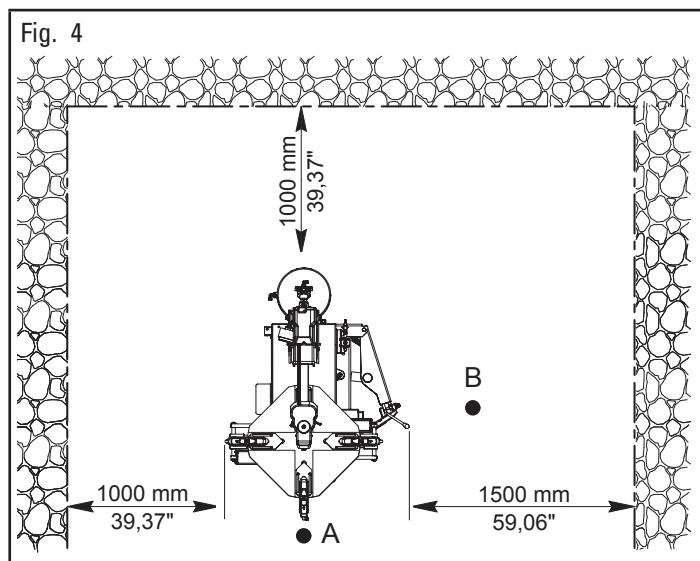

The location of the machine requires a usable space as indicated in Figure 4. The positioning of the machine must be according to the distances shown. From the control position the operator is able to observe all the machine and surrounding area. He must prevent unauthorized personnel or objects that could be dangerous from entering the area.

The machine must be fixed on a flat floor surface, preferably of cement or tiled. Avoid yielding or irregular surfaces. The base floor must be able to support the loads transmitted during operation. This surface must have a capacity load of at least 500 kg/m².

The depth of the solid floor must be sufficient to guarantee that the anchoring bolts hold.

8.3 Lighting

The machine does not require its own lighting for normal working operations.

However, it must be placed in an adequately lit environment.

For correct lighting, use lamps having total power 800/1200 Watt as envisaged by UNI 10380.

9.0 ANCHORING SYSTEM

The packed machine is fixed to the support pallet through the holes prearranged on the frame. Such holes can be used also to fix the machine to the ground, through floor anchor small blocks (excluded from supply). Before carrying out the definitive fixing, check that all the anchor points are laid down flat and correctly in contact with the fixing surface itself. If not so, insert shimming profiles between the machine and the fixing lower surface, as indicated in Fig. 5.

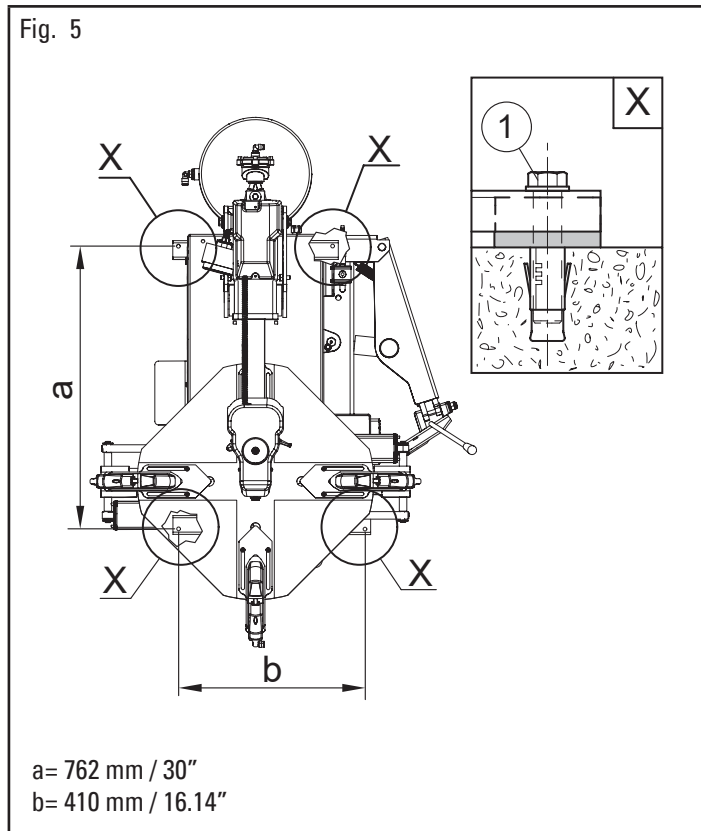

- Execute 4 holes with 10 mm diameter on the floor by the holes on the bottom floor;
- insert the small blocks (excluded from supply) into the holes;
- fix the machine to the ground with 4 M8x80 mm screws (excluded from supply) (Fig. 5 ref. 1) (or with 4 8x80 mm stud bolts (excluded from supply)). Tighten the screws with an approximate tightening torque of 70 Nm.

10.0 ASSEMBLY AND PREPARATION FOR USE



EACH MECHANICAL INTERVENTION MUST BE CARRIED OUT BY PROFESSIONALLY QUALIFIED STAFF.

After having freed the various components from the packing check that they are complete, and that there are no anomalies, then comply with the following instructions for the assembly of the components making use of the attached series of illustrations.

10.1 Fixtures contained in the packing

The packing case contains also the fixtures box. Check that all the parts listed are there.

Description	Qty
Lever	1
4 tool protections set	1
Bead breaker vane guard	1
Mounting grease	1
Brush	1
Standard clamp protections for alloy rims	4
1/4 JAP/A10 male quick coupling (for model without tubeless inflation only)	1
1/4 JAP/A10 female quick coupling (for models with tubeless inflation only)	1

10.2 Assembly procedures

Remove the packaging and free the machine from the wrapping. Lift the machine and position it on the floor.

10.3 Post unit assembly

In case the post unit is supplied demounted, proceed following the instructions below.

1. Remove the fixing elements needed to fix the machine to the pallet.
2. Unpack the vertical post unit (Fig. 6 ref. 1) and put it vertically onto the base.
3. Put the post unit (Fig. 6 ref. 1) onto the base (Fig. 6 ref. 2) and fit the pin (Fig. 6 ref. 3) into the special hole (Fig. 6 ref. 4) and block it through the washers (Fig. 6 ref. 5), the spacers (Fig. 6 ref. 6) and the screws (Fig. 6 ref. 7). Fix the post unit tilting control cylinder (Fig. 6 ref. 8) using the pin (Fig. 6 ref. 9) and the seegers (Fig. 6 ref. 10).

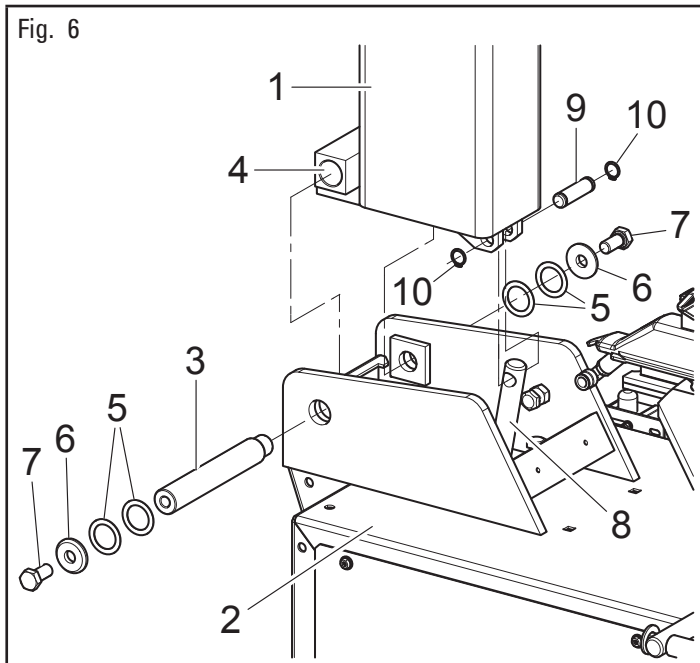

4. At the end mount the post unit covering by means of the supplied screws and washers.

10.4 Bead breaker arm mounting

Secure the beading arm vane (Fig. 7 ref. 1) using the washers (Fig. 7 ref. 2) and the nut (Fig. 7 ref. 3), on issue (nut and washers are clamped on the bead breaker vane).

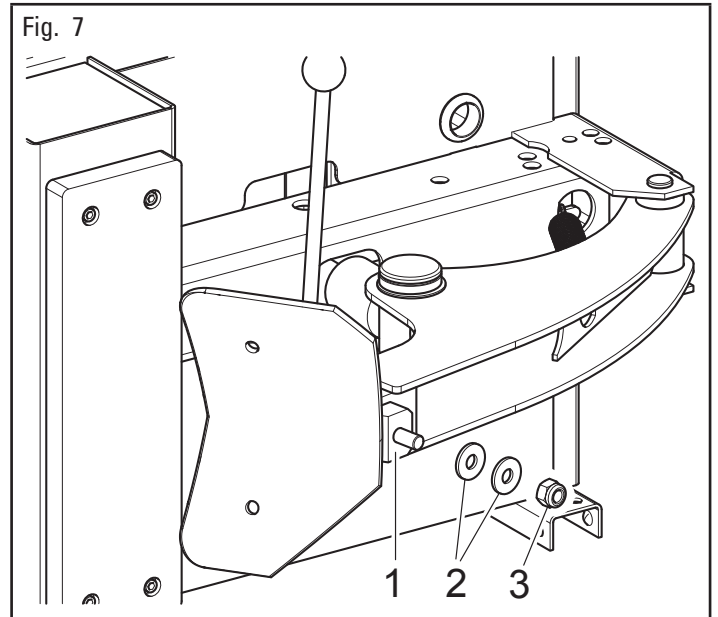

10.5 Tubeless inflation mounting (only for versions with tubeless inflation)

1. Mount the tank (Fig. 8 ref. 1) on the base rear part, as shown in Fig. 8, using the screws (Fig. 8 ref. 2) (tightening torque approx. 8 N·m), the washers (Fig. 8 ref. 3) and the nuts (Fig. 8 ref. 4).

Fig. 8

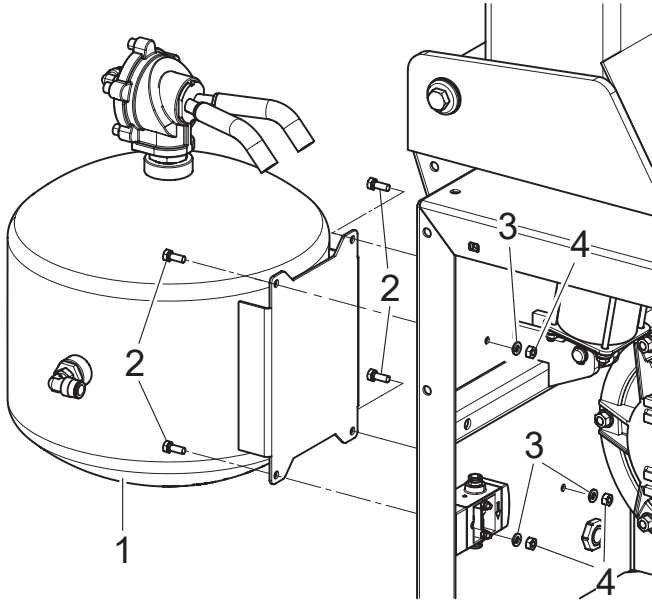

2. Connect the flexible pipes (Fig. 9 ref. 1) preassembled on the chuck rotary distributor (Fig. 9 ref. 2), on the valve (Fig. 9 ref. 4) hosesnipper (Fig. 9 ref. 3). Fasten the pipes (Fig. 9 ref. 1) with the prepared clamps (Fig. 9 ref. 5).
3. Connect the pipe (Fig. 9 ref. 14) from the greaser reduction gear filter (Fig. 9 ref. 7) (air not lubricated) to the pedalboard (Fig. 9 ref. 12).
4. Connect the pipe (Fig. 9 ref. 11) from the pedal board lower valve (Fig. 9 ref. 12) to the blow valve (Fig. 9 ref. 4) union (Fig. 9 ref. 13).
5. Connect the pipe (Fig. 9 ref. 6) to the T coupling (Fig. 9 ref. 8) and to the coupling (Fig. 9 ref. 16) placed on the tank (Fig. 9 ref. 9).
6. Connect the pipe (Fig. 9 ref. 10) from the valve (Fig. 9 ref. 15) to the pedalboard (Fig. 9 ref. 12).
7. Connect the pipe (Fig. 9 ref. 17) from the valve (Fig. 9 ref. 15) to the inflation unit (Fig. 9 ref. 18).

Fig. 9

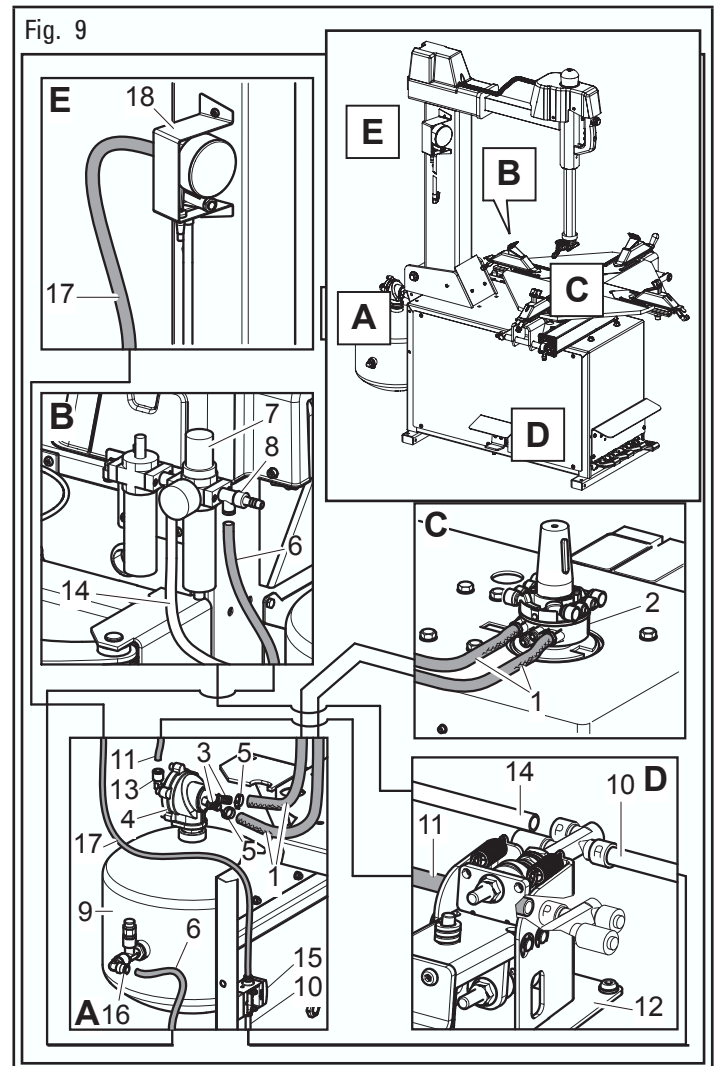

IN CASE OF A CHANCE SUPPLY FAILURE, AND/OR BEFORE ANY PNEUMATIC CONNECTIONS, MOVE THE CONTROLS TO THE NEUTRAL POSITION.

10.6 Electrical connections



EVEN THE TINIEST PROCEDURE OF AN ELECTRICAL NATURE MUST BE CARRIED OUT BY PROFESSIONALLY QUALIFIED STAFF.



BEFORE CONNECTING THE MACHINE MAKE SURE THAT:

- POWER LINE SPECIFICATIONS CORRESPOND TO MACHINE REQUIREMENTS AS SHOWN ON THE MACHINE PLATE;
- ALL MAIN POWER COMPONENTS ARE IN GOOD CONDITION;
- THE ELECTRICAL SYSTEM IS PROPERLY GROUNDED (GROUND WIRE MUST BE THE SAME CROSS-SECTION AREA AS THE LARGEST POWER SUPPLY CABLES OR GREATER);
- MAKE SURE THAT THE ELECTRICAL SYSTEM FEATURES A CUTOUT WITH DIFFERENTIAL PROTECTION SET AT 30 MA.

As envisaged by the regulations in force, the machine is not equipped with a master circuit breaker, but simply has a plug-socket connection to the electrical mains.

The machine is supplied with a cable with a suitable plug.



FIT A TYPE-APPROVED PLUG TO THE MACHINE CABLE (THE GROUND WIRE IS YELLOW/GREEN AND MUST NEVER BE CONNECTED TO ONE OF THE PHASE LEADS).



MAKE SURE THAT THE ELECTRICAL SYSTEM IS COMPATIBLE WITH THE RATED POWER ABSORPTION SPECIFIED IN THIS MANUAL AND APT TO ENSURE THAT VOLTAGE DROP UNDER FULL LOAD WILL NOT EXCEED 4% OF RATED VOLTAGE (10% UPON START-UP).



IN CASE OF A CHANGE SUPPLY FAILURE, AND/OR BEFORE ANY POWER SUPPLY CONNECTIONS, MOVE THE PEDALS TO THE NEUTRAL POSITION.

Models	Conformity standard	Voltage	Amperage	Poles	Minimum IP rating
1-Ph-adjustable speed	IEC 309	240 V	16 A	2 Poles + Ground	IP 44
3-Ph-2-speed		400 V		3 Poles + Ground	IP 54

10.7 Check of motor rotation direction

Once all power connections have been made, make sure that the chuck is rotating in the right direction (pedal lowered, clockwise rotation). If the direction of rotation is wrong, swap two phase wires in the plug.



FAILURE TO OBSERVE THE ABOVE INSTRUCTIONS WILL IMMEDIATELY INVALIDATE THE WARRANTY.

10.8 Air connection



EACH PNEUMATIC INTERVENTION MUST BE CARRIED OUT BY PROFESSIONALLY QUALIFIED STAFF.

Connect the tyre changer to the workshop compressed air system by means of plug (Fig. 10 ref. 1).

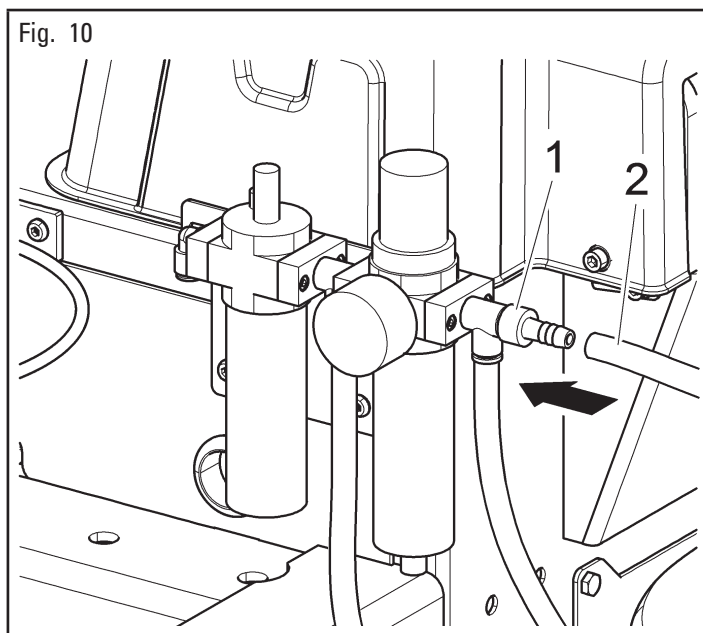

The pressurized pipe coming from the mains must have a section of 1/4x10 (Fig. 10 ref. 2).

The filter unit is already mounted on the machine.

10.9 Checks



BEFORE STARTING UP THE TYRE-CHANGER, BE SURE TO BECOME FAMILIAR WITH THE LOCATION AND OPERATION OF ALL CONTROLS AND CHECK THEIR PROPER OPERATION (SEE PAR. "CONTROLS").



CARRY OUT A DAILY CHECK OF THE MAINTAINED ACTION CONTROLS CORRECT FUNCTIONING, BEFORE STARTING MACHINE OPERATION.

11.0 CONTROLS

The pedal control unit comprises 4 (four) pedals.

11.1 4 pedals control unit

"Pedal 1" on this type of pedal control unit activates the automatic post unit and has two fixed operative functions:

the first one (with pedal up) overturns the post unit from the operator's opposite side; the second one (with pedal down) brings back the post to working position.

"Pedal 2" opens and closes chuck locking clamps. It has three stable positions: open – close – approach clamps.

"Pedal 3" has 2 operative positions: when it is pressed downwards, the cylinder for bead breaking with lateral arm (A) is operated; when such pedal is released, the bead breaking arm is moved back to the initial position (open bead breaker) (B).

"Pedal 4" controls chuck's plate rotation and has 3 stable positions:

1. 0 position, turntable stopped;
2. Pressed down, the turntable is rotated clockwise;
3. Raised, the turntable is rotated anti-clockwise.

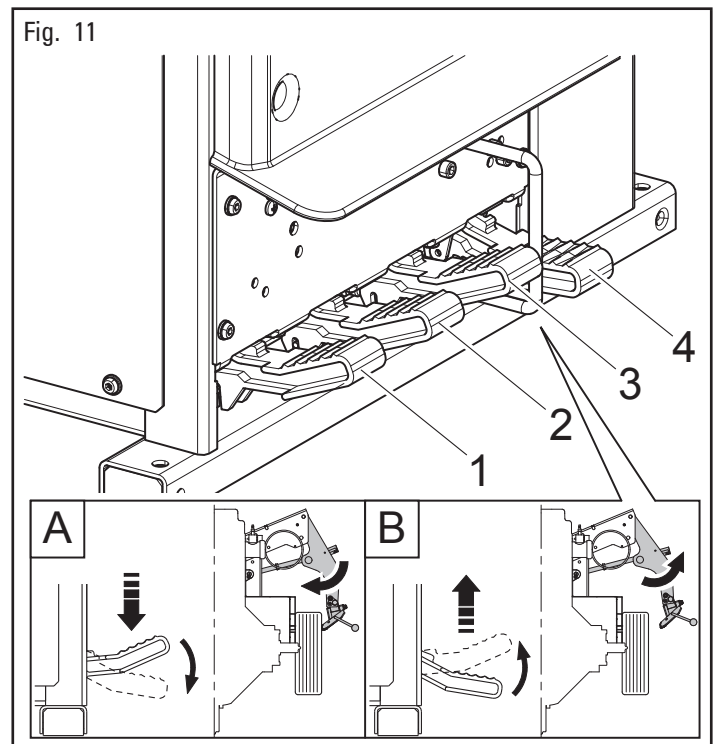

ONLY FOR VERSIONS WITH THREE-PHASE 220/400V - 50 HZ 2-SPEED

"Pedal 4" controls chuck's plate rotation and has 4 stable positions:

1. 0 position, turntable stopped;
2. Position 1 downwards - clockwise rotation of turntable;
3. Position 2 downwards from position 1 - clockwise rotation of turntable at double speed;
4. Position 1 upwards - counterclockwise rotation of turntable.

11.2 Inflation pedal (on demand)

The pressure on the inflation pedal, with a maintained action, delivers air at controlled pressure (max. $4,2 \pm 0,2$ bar).

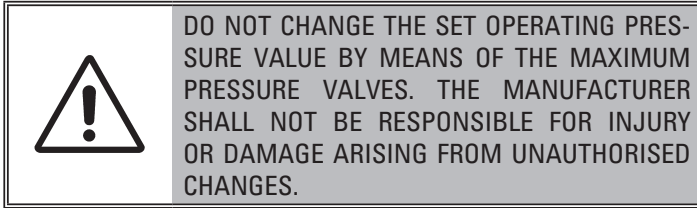

11.3 Additional pedal for devices with tubeless inflation

The inflating pedal (Fig. 12 ref. 1) has three positions:

- lowered (unstable) to cause air (contained in the reservoir) to be jetted out through air lances;
- middle stroke (unstable): it lets air out from inflating head;
- released (stable): it closes all air outlets.

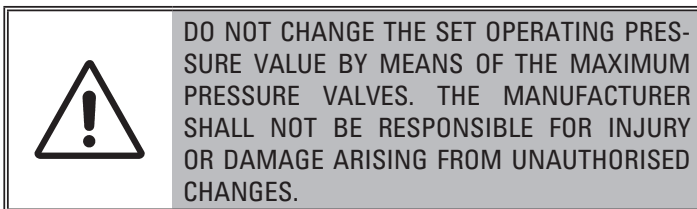
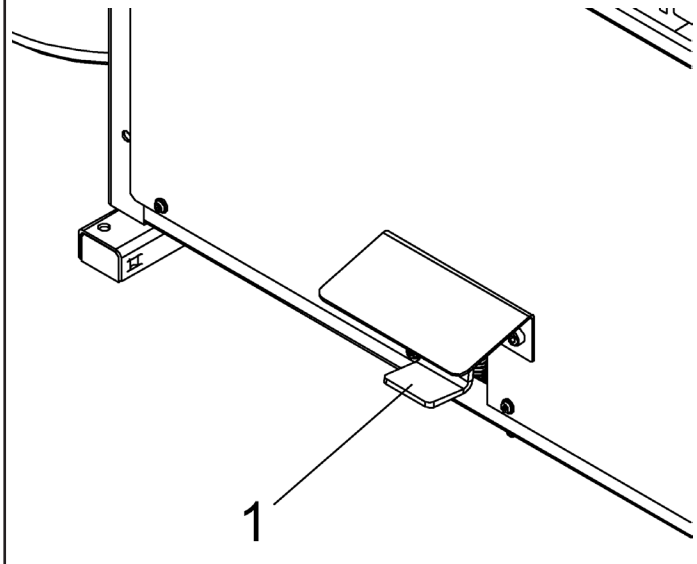

Fig. 12



11.4 Post unit handle manual adjustment

A pneumatically controlled handle on the post unit allows the locking and unlocking of the vertical and horizontal arm.

Pushing the push button located on this handle (Fig. 13) the following operations can be carried out:

- 1st tripping: locking of the vertical and horizontal arm in working position;
- 2nd tripping: unlocking of vertical and horizontal arm and manual rise of vertical arm in rest position (all upward).

Fig. 13

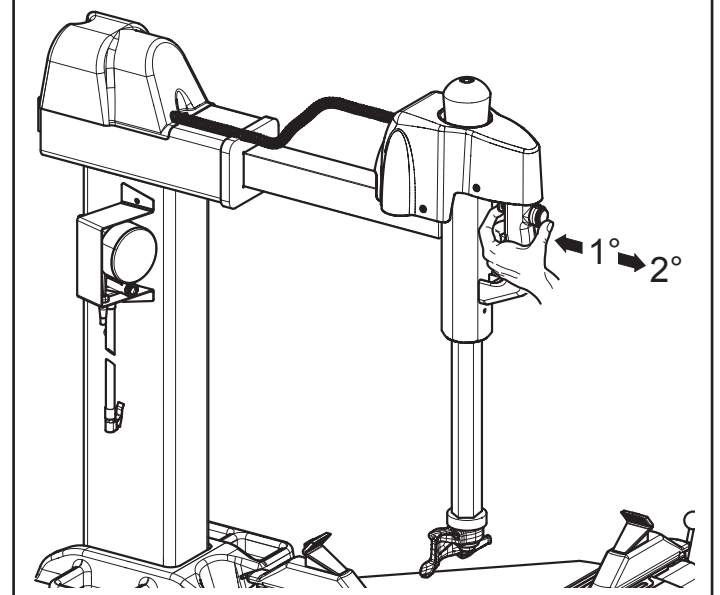

12.0 USING THE MACHINE

12.1 *Precaution measures during tyre removal and fitting*



Before fitting a tyre, observe the following safety rules:

- rim and tyre must always be clean, dry and in good condition; if necessary, clean the rims and check that:
 - neither the bead nor the tread of the tyre are damaged;
 - the rim does not produce dents and/or deformation (especially for alloy rims, dents can cause internal micro-fractures, that pass unobserved at visual inspection, and can compromise the solidity of the rim and constitute danger even during inflation);
- adequately lubricate the contact surface of rim and the tyre beads, using specific tyre lubricants only;
- replace the inner tube valve with a new valve, if the tyre tube has a metal valve, replace the grommet;
- always make sure that tyre and rim sizes are correct for their coupling; on the contrary, never fit a tyre unless you are sure it is of the right size (the rated size of rim and tyre is usually printed directly on them);
- do not use compressed air or water jets to clean the wheels on the machine.

12.2 *Preliminary operations - Preparing the wheel*

- Remove the wheel balancing weights from both sides of the wheel.



REMOVE THE VALVE STEM AND ALLOW THE TYRE TO COMPLETELY DEFLATE.

- Establish from which side the tyre should be demounted, checking the position of the groove.
- Find the rim locking type.
- Try to establish the special types of wheels, such as "TD" and "AH", in order to improve locking, bead breaking, assembly and disassembly performances.



WHEN HANDLING WHEELS WEIGHING MORE THAN 10 KG AND/OR WITH A FREQUENCY OF MORE THAN 20/30 WHEELS PER HOUR, A LIFTING DEVICE SHOULD BE USED.

12.3 *Bead breaking*



TYRE BEADING MUST BE CARRIED OUT AFTER THE TYRE HAS BEEN COMPLETELY DEFLATED AND OBSERVING ALL SAFETY RULES: BEADING PEDAL START-UP CAUSE SUDDEN, STRONG ARM CLAMPING, THUS REPRESENTING POTENTIAL CRUSHING DANGER FOR ANYTHING WITHIN THE OPERATING AREA. DO NOT KEEP YOUR HANDS ON TYRE SIDES DURING BEAD BREAKING. DURING TYRE BEADING SUDDEN NOISE LEVEL PEAKS CAN OCCUR: THEREFORE THE USE OF SAFETY EAR-CAPS IS RECOMMENDED.

After preparing the wheel as described in the previous point, follow the instructions given below to carry out the bead breaking procedure:

1. Position the wheel as indicated in Fig. 14 and move the bead breaker tool toward the edge of the rim.



PLACE THE VANE CORRECTLY, SO THAT IT CAN OPERATE ON TYRE SIDE AND NOT ON THE RIM.

2. Operate the bead breaker vane by pressing the relative pedal until the bead has detached. If the bead does not detach the first time, repeat the operation, on different points of the wheel, until it has come away completely.
3. Reverse the position of the wheel and repeat the operation on the other side.
4. Lubricate the tyre carefully along the entire circumference of the bead on both sides. Failure to lubricate might cause friction between the mounting tool and the tyre, and would cause damage to the tyre and/or the bead.

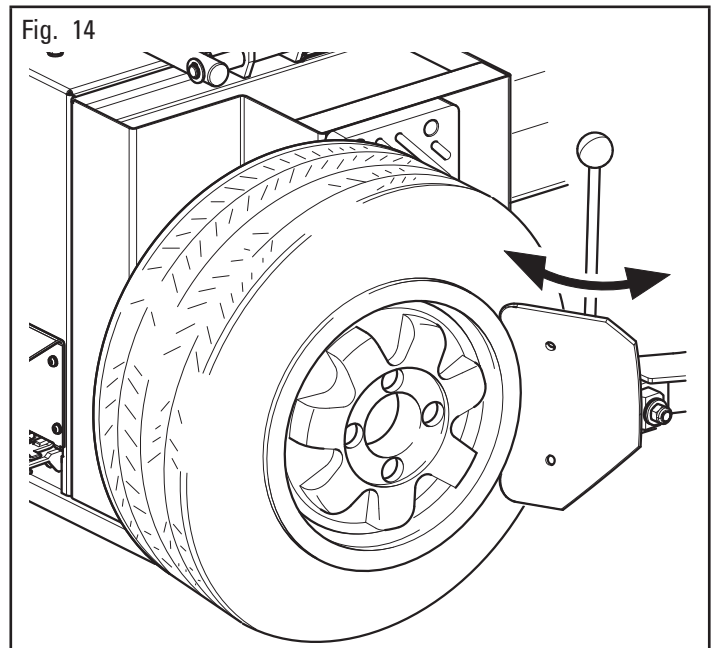

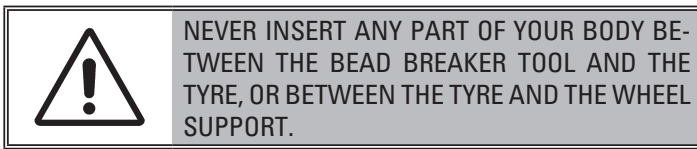

12.4 Wheel clamping on the chuck

To block the wheel from inside:

1. Grease tyre edges carefully, with the grease contained in the appropriate cup (see operating figure Fig. 15).
2. Release the hexagon shaft (Fig. 15 ref. 2) through the relevant push button on handle (Fig. 15 ref. 1) and take it up, fully home. Control horizontal arm (Fig. 15 ref. 3) tilting through the pedal.
3. The wheel can be secured to the chuck by placing clamps either inside or outside the rim (see Chapter 15 "Technical specifications" for required rim size).



Make sure the wheel is placed at the centre of chuck's plate (Fig. 15 ref. 6). Make sure the wheel is clamped by clamps (Fig. 15 ref. 7) symmetrically.

A) WHEEL SECURING OUTSIDE THE RIM (for allowed rim size, see Chapter 15 Technical specifications)

In order to carry out the clamping of the wheel from the outside:

1. pressing pedal (Fig. 15 ref. 9) in intermediate position, place the 4 fixing clamps (Fig. 15 ref. 7) at about the same level of tyre diameter.
2. Place the wheel on the chuck, press the rim downward and completely lower pedal (Fig. 15 ref. 9) to secure the wheel.

B) WHEEL SECURING INSIDE THE RIM (for allowed rim size, see Chapter 15. Technical specifications)

To block the wheel from inside:

1. close preventively fixing clamps (Fig. 15 ref. 7), by means of pedal (Fig. 15 ref. 9). Place the wheel on the chuck. Push down the rim while completing lowering the pedal and releasing it. The clamps release, thus securing the rim.

Fig. 15

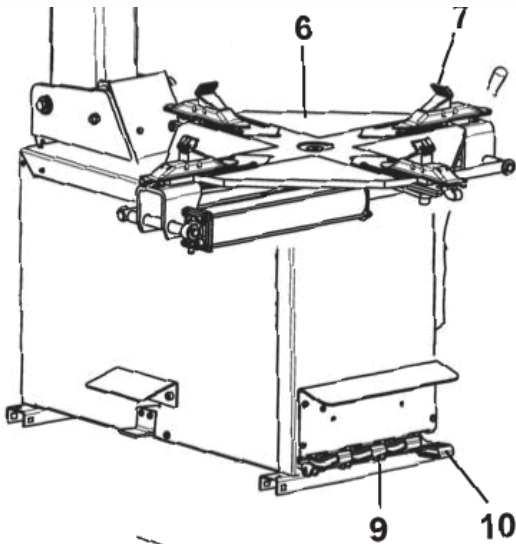
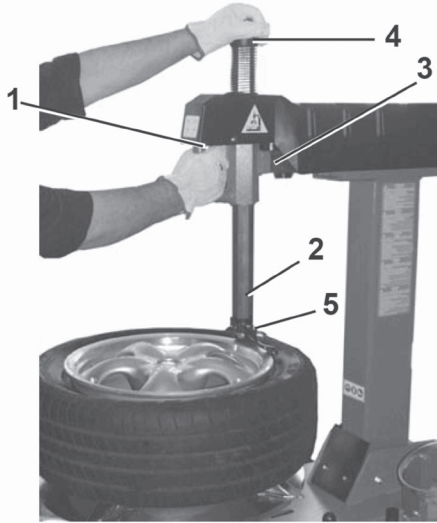

12.5 Demounting



KEEP YOUR HANDS AND BODY AWAY FROM MOUNTING TOOL DURING DISASSEMBLY/ASSEMBLY OPERATIONS TO AVOID SQUASHING DANGER.

After clamping the wheel, the tyre is demounted following the instructions given below, with reference to Fig. 16.

1. Press the rotation pedal to rotate the wheel clockwise until the valve stem reaches "hour 1" position.
2. Place arm (Fig. 15 ref. 3) in working position.



WHEN PLACING ARM IN WORKING POSITION, DO NOT LEAN HANDS ON THE RIM: DANGER OF SQUEEZING BETWEEN HEAD AND RIM.

3. Release the hexagon shaft (Fig. 15 ref. 2) and set tool (Fig. 15 ref. 5) radially and vertically on rim and lock it in place using the push button on handle (Fig. 15 ref. 1);
4. operate lever (Fig. 16 ref. 1) to push the tyre bead, laying it on the head nail (Fig. 16 ref. 2).
5. While keeping the lever in this position, turn the chuck clockwise by means of pedal (Fig. 15 ref. 10), until the bead is out of the rim. Operate the pedal by quickly pressing and releasing it.



WHEN OPERATING ON VERY "HARD" RIMS, THE TYRE BEAD TENDS TO SLIP DOWN THE HEAD. BEFORE TURNING THE CHUCK CLOCKWISE, TURN IT ANTICLOCKWISE BY A FEW CENTIMETERS WHILE KEEPING LEVER (Fig. 16 ref. 1) IN THE SAME POSITION.

Fig. 16

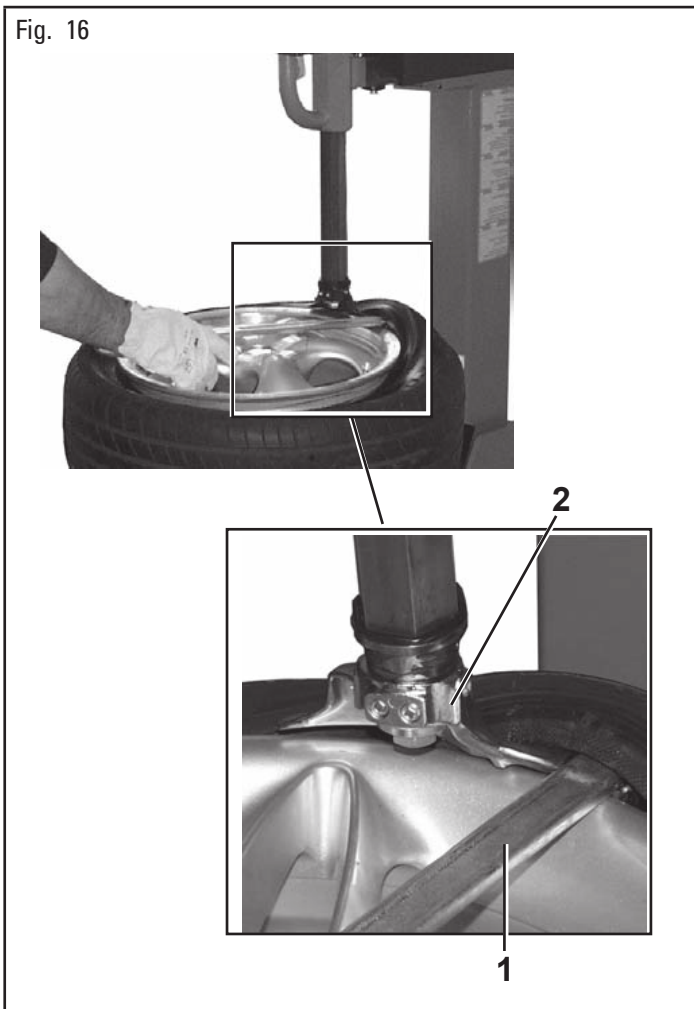

6. remove the inner tube (if fitted);
7. place the head as indicated in point 3; then by means of lever (Fig. 17 ref. 1) place the second tyre bead on the head nail (Fig. 17 ref. 2);
8. while keeping the lever (Fig. 17 ref. 1) in this position, turn the chuck clockwise until the tyre is completely out of the rim.
9. place the arm in idle position and remove the tyre from the rim.

Fig. 17

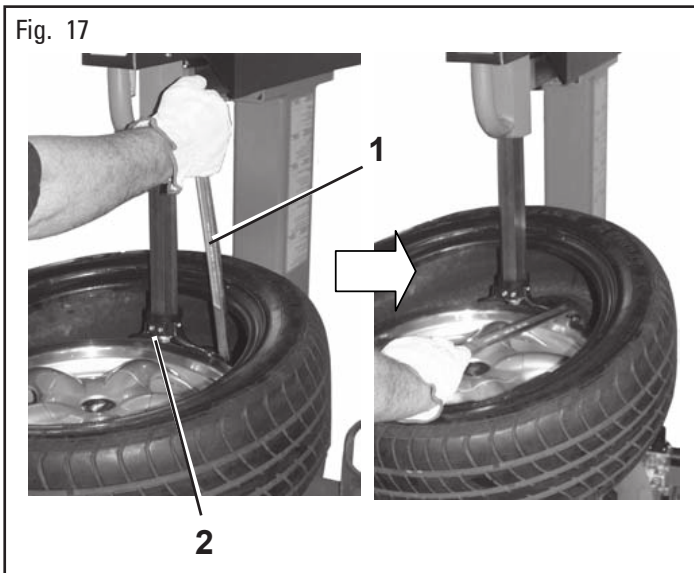

10. When demounting hard tyres, it may happen that the bead comes onto the mounting tool with the lip turned. This causes the bead to slide from the lever when clockwise rotation begins. To avoid this problem rotate the wheel slightly anti-clockwise until the bead flattens. Now the clockwise demounting cycle can begin (See Fig. 18).

Fig. 18

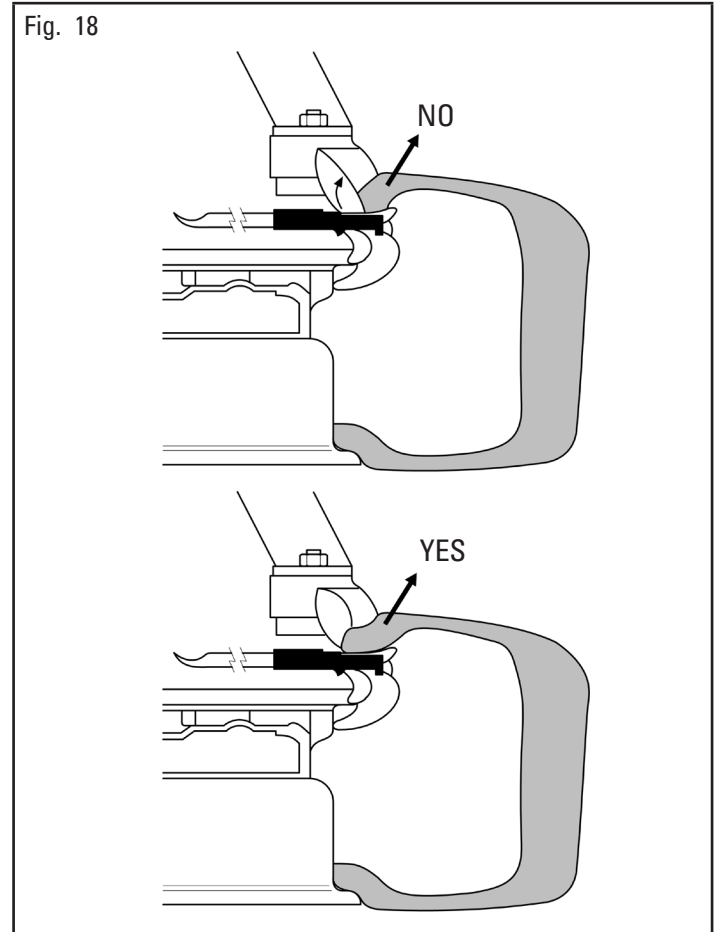

If the motor slows down or stops during tyre demounting and mounting, make the following checks:

- check that the bead has been lubricated;
- check that the bead has been pushed into the groove;
- check that the right side of the rim has been chosen for demounting or mounting the tyre;
- check that the rim groove is not off-centre.

12.6 Setting the tool for tyre fitting and removal

The tool is locked in position to a hexagonal post unit through 4 upper horizontal-axis dowels and a lower vertical-axis screw. The adjusting clamps lock the tool in its working position. Adjusting clamps also set head distance from the wheel rim. Head top is concave for smoother positioning. For tool setting a 14" rim with good concentricity degree and standard profile, better if with flat upper edge and proper right angle to its spin axis, is required.

12.6.1 Setting neck travel



SET THE NECKS BEFORE POSITIONING THE HEAD. AT THIS STAGE THE HEAD HAS NOT BEEN SET TO ITS FINAL POSITION YET BUT IT IS CLOSE TO ITS FINAL POSITION BEING LOCKED THROUGH THE UPPER DOWELS.

- Setting the travel (Fig. 19)
Tyre changers equipped with collapsible post unit and telescopic arm, tyre changers, have both horizontal and vertical adjusting necks for horizontal and vertical distance of the head from the rim, respectively. The horizontal neck must be adjusted by turning nut A, when the air-operated cylinder has been depressurized (remove upper guard and tighten the nut A1 first so to keep the neck horizontally, that is it should be perpendicular to the hex shaft):
 - turn the nut A clockwise for shorter travel of the head;
 - turn the nut A anti-clockwise for longer travel of the head.
 The vertical neck must be adjusted by turning nut B, when the air-operated cylinder has been depressurized (remove upper guard and tighten the nut B1 first to lock the cone in a fixed position with respect to the roller – see Fig. 19).
 - turn the nut B clockwise for shorter travel of the head;
 - turn the nut B anti-clockwise for longer travel of the head.

Fig. 19

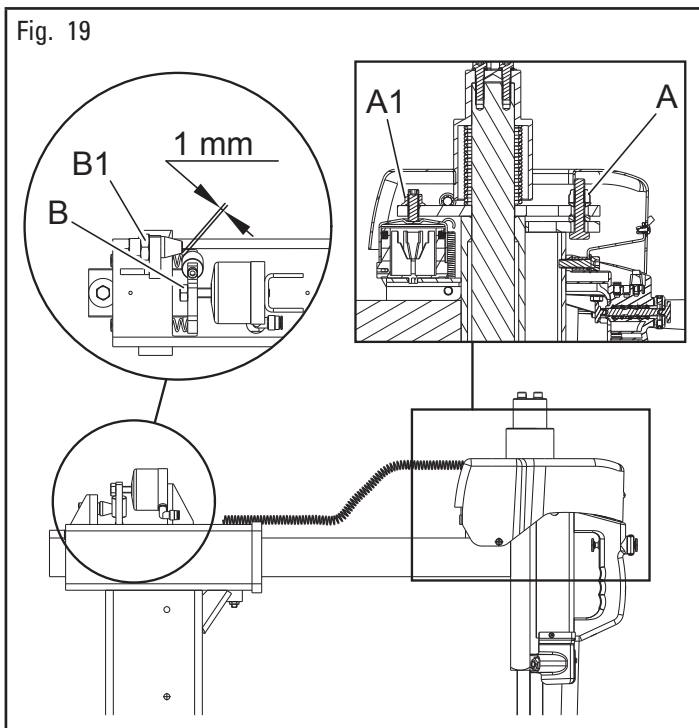

12.6.2 Setting the tool for tyre fitting and removal

When finished with neck adjustment, set head position along its three orthogonal axes using the 14" diameter sample rim. Tighten the dowels and the lower screw firmly to lock the head in position. When finished, correct head working position (equipped with roller or insert) when locked should be as shown in Fig. 20A-20B. Tighten bolts and nuts to the following torque values:

- lower screw: 70 Nm.
- neck bolts: 40 Nm.

Fig. 20

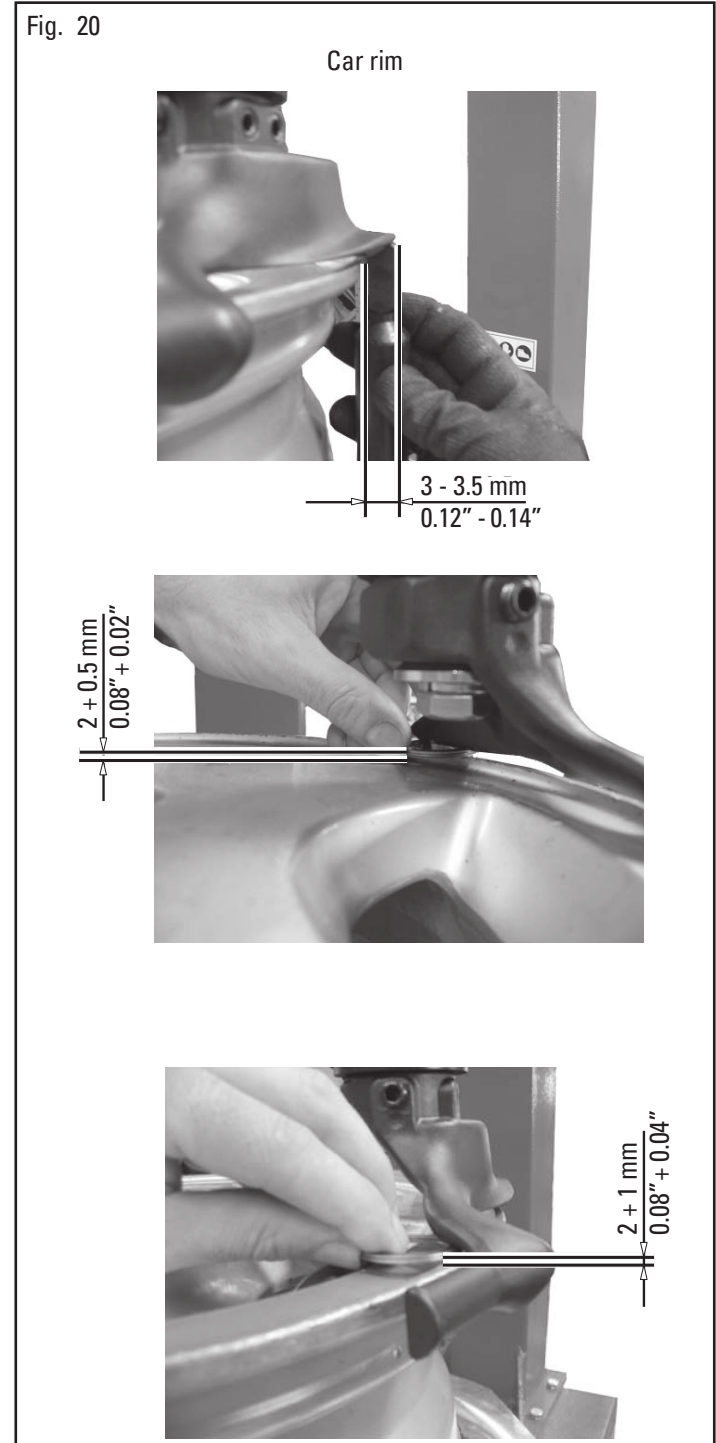
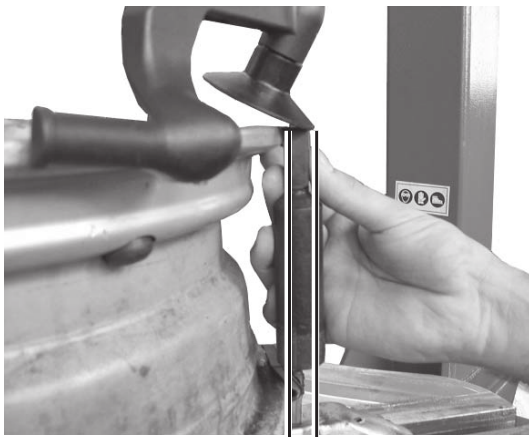
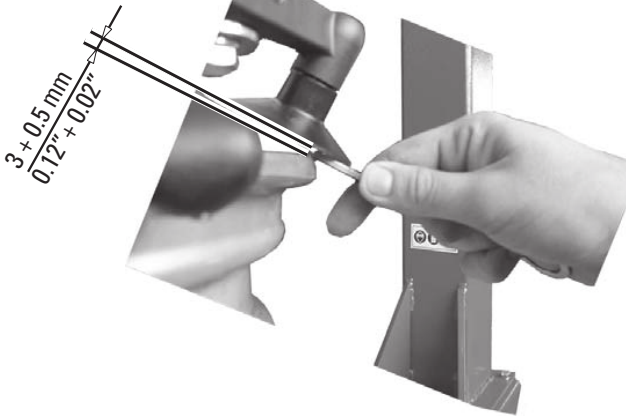

Fig. 20B

Rims with projecting spokes



$12 + 0.5 \text{ mm}$
 $0.47'' + 0.02''$



$3 + 0.5 \text{ mm}$
 $0.12'' + 0.02''$



$2 + 1 \text{ mm}$
 $0.08'' + 0.04''$

12.7 Mounting the tyre



KEEP YOUR HANDS AND BODY AWAY FROM MOUNTING TOOL DURING DISASSEMBLY/ASSEMBLY OPERATIONS TO AVOID SQUASHING DANGER.

To mount the tyre, proceed as follows:

1. Position the work arm in working position depressing pedal (Fig. 21 ref. A).

Fig. 21

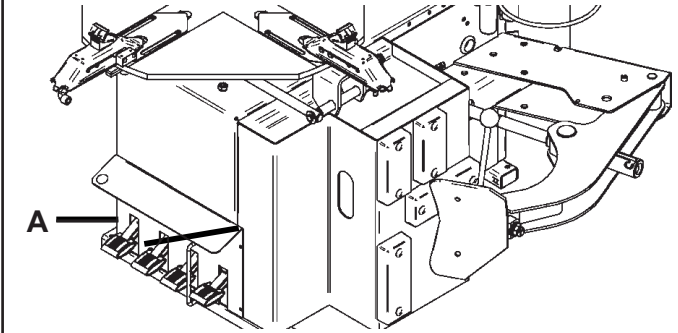

WHEN PLACING ARM IN WORKING POSITION, DO NOT LEAN HANDS ON THE RIM: DANGER OF SQUEEZING BETWEEN HEAD AND RIM.

2. Place head (Fig. 22 ref. 1) against the rim edge and lock arm (Fig. 22 ref. 2).



IF TYRE IS FITTED ON THE WHEEL PREVIOUSLY REMOVED OR WHEEL SIZE CORRESPONDS TO RIM SIZE, IT IS NOT NECESSARY TO OPERATE HANDLE (Fig. 22 ref. 3) TO SECURE AND RELEASE THE HEAD, ONLY ARM (Fig. 22 ref. 2) NEEDS TO BE REPOSITIONED.

3. Use Your hands to guide the tyre, so that the bead passes under head nail (Fig. 22 ref. 1) and outside its support lip (see Fig. 22 for lower bead).



WITH TUBELESS-TYPE TYRES, START ASSEMBLY PROCEDURES WITH VALVE SET AT 180° WITH RESPECT TO THE HEAD ("5/6 O' CLOCK").

- Turn chuck (Fig. 22 ref. 4) clockwise. Press the corresponding pedal and keeping the tyre bead pressed with Your hands in the inner rim groove.

Fig. 22

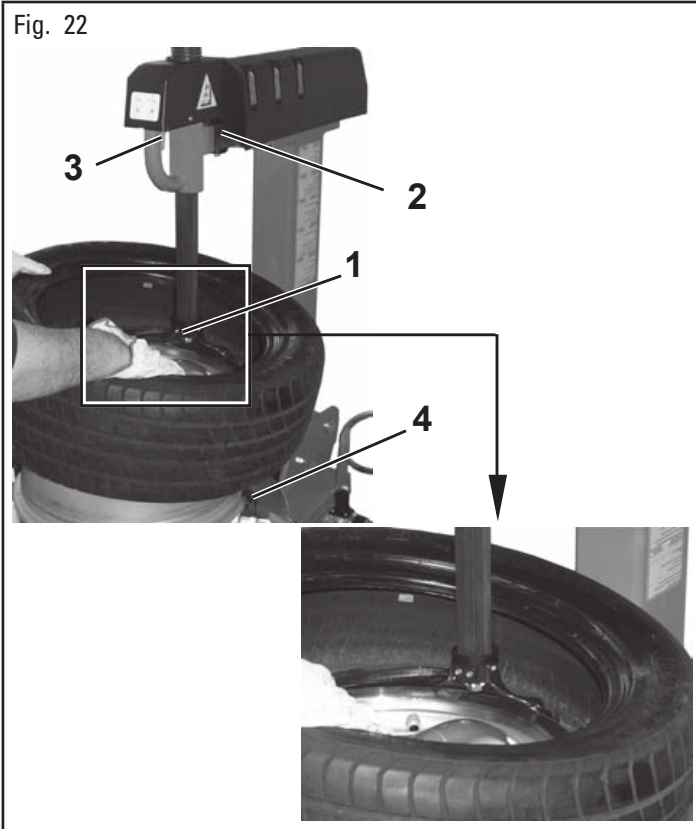

BE VERY CAREFUL, KEEP HANDS AND OTHER BODY PARTS FAR OFF THE HEAD WHEN THE CHUCK IS TURNING: DANGER OF SQUEEZING.

- If an "inner tube" tyre must be fitted, insert the inner tube after the first bead is completely inside the rim;
- repeat the same operations for the upper tyre bead, as shown in Fig. 23;
- once assembly is completed, remove arm and take it to rest position by depressing pedal (Fig. 21 ref. A);
- push the pedal to release the wheel from the chuck.

Fig. 23

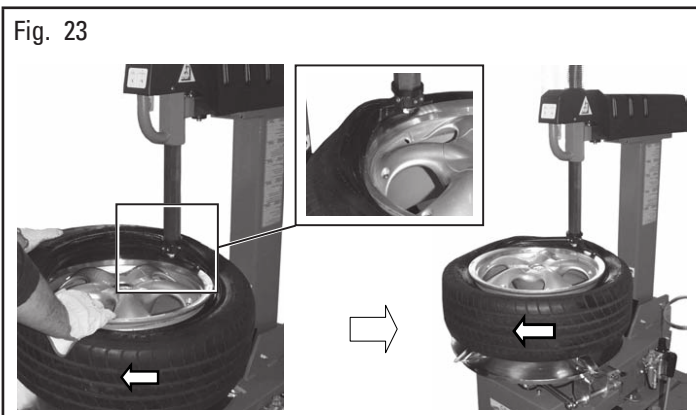

BOTH TYRE FITTING AND REMOVAL MUST BE CARRIED OUT WITH THE CHUCK TURNING CLOCKWISE. TURN THE CHUCKING TABLE ANTICLOCKWISE ONLY IF ADJUSTMENTS ARE REQUIRED.

12.8 Tyre inflation



TYRE INFLATING OPERATIONS ARE HAZARDOUS FOR THE OPERATOR; MOREOVER, IF NOT PROPERLY EXECUTED, THEY CAN CAUSE DAMAGE TO THE USERS OF THE VEHICLE WHERE THE TYRES ARE FITTED.



STANDARD OR OPTIONAL INFLATING UNITS FITTED ON TYRE CHANGERS ARE ALWAYS EQUIPPED WITH A PRESSURE LIMITING DEVICE WHICH ALMOST ELIMINATES ANY RISK OF TYRE EXPLOSION DURING INFLATING. HOWEVER, A RESIDUAL RISK OF EXPLOSION STILL EXISTS. THEN THE FOLLOWING PRECAUTIONS MUST BE RESPECTED:

- OPERATORS SHOULD WEAR SUITABLE PROTECTIVE CLOTHING LIKE: GLOVES, SAFETY EYEWEAR AND EARCAPS.
- BEFORE FITTING A TYRE, CHECK TYRE AND RIM CONDITIONS AS WELL AS THEIR PROPER COUPLING.
- MAKE SURE THAT THE TYRE IS PROPERLY POSITIONED ON THE MACHINE: THE WHEEL OUTER PART MUST NOT BE SECURED ON THE CLAMPS.
- CORRECT WORKING POSITION: DURING TYRE BEADING AND INFLATING THE OPERATOR MUST KEEP HIS BODY AS FAR AS POSSIBLE FROM THE TYRE.
- COMPLIANCE WITH TYRE MANUFACTURER'S SPECIFICATIONS FOR TYRE INFLATION PRESSURE.



IF MEASURED PRESSURE EXCEEDS 4,2 BAR, IT MEANS THAT THE PRESSURE LIMITING VALVE AND/OR PRESSURE GAUGE IS NOT WORKING PROPERLY. IN THIS CASE, DEFLATE THE TYRE ON THE SPOT AND CONTACT AN AUTHORIZED SERVICE CENTRE TO VERIFY EQUIPMENT OPERATION. MAKE SURE OF THE PROPER OPERATION OF THE INFLATING EQUIPMENT BEFORE USING IT.

12.8.1 Tyre inflation with pressure gauge (on demand)

Connect the inflation device to the tyre valve and inflate the tyre using the left pedal.

Well lubricated beads and rims make the beading in and inflation much safer and easier.



A LIMITATION DEVICE IS PRESENT IN THE AIR SUPPLY LINE FOR THE TYRE INFLATION ($4,2 \pm 0,2$ BAR/60 PSI).

In case the beads are not seated at 4.2 ± 0.2 bar, release all the air from the wheel, remove it from the tyre changer and put it in a safety cage to complete the inflation procedure.

12.8.2 Tyre inflation device with Tubeless inflation unit

Some types of tyre can be difficultly inflated if the beads are not in contact with the rim.

The tubeless inflating device, assembled only on some models, supplies air at high pressure from chuck nozzles (Fig. 24 Ref. 1) and therefore facilitates the positioning of the beads against the rim starting the normal inflation of the tyre.

In order to carry out the inflation of the tyre on these models follow these indications:

- Connect the inflation terminal to the valve of the tyre.
- Lift the lower bead while the pedal, placed on the left side of the machine, is pushed at its second stage, supplying that way the required air jet.
- Go on inflating the tyre until the required pressure is reached with the lateral pedal pushed on its first stage.



IN ORDER TO ALLOW THE AIR JET TO BREAK BOTH BEADS, DO NOT KEEP THE BEAD LIFTED FORCING IT.

Fig. 24

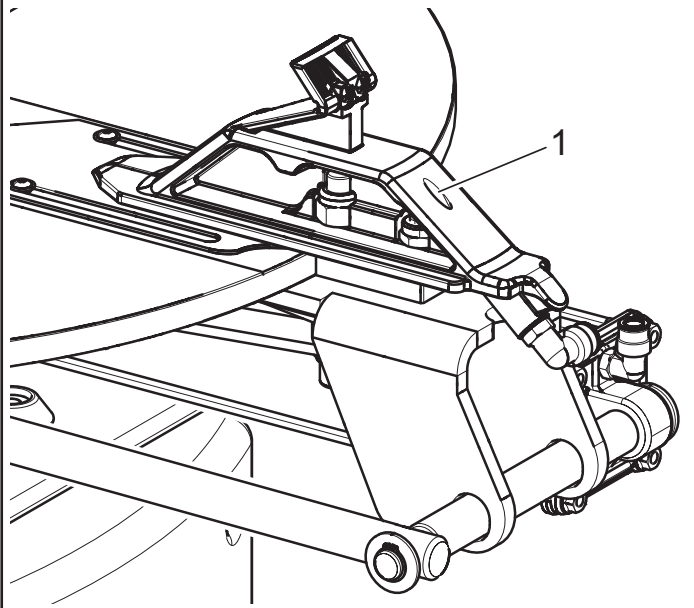

13.0 ROUTINE MAINTENANCE



BEFORE CARRYING OUT ANY ROUTINE MAINTENANCE PROCEDURE, DISCONNECT THE MACHINE FROM ITS POWER SUPPLY SOURCES, TAKING SPECIAL CARE OF THE ELECTRICAL PLUG/SOCKET CONNECTION.

To guarantee the efficiency and correct functioning of the machine, it is essential to carry out daily or weekly cleaning and weekly routine maintenance, as described below.

Cleaning and routine maintenance must be conducted by authorized personnel and according to the instructions given below.

- Disconnect the mains power supply before starting any cleaning or routine maintenance operations.
- Periodically check the calibration of the lubricator of the pressure regulator/oiler unit: 1 oil drop every four complete strokes of chuck clamps.
- Remove deposits of tyre powder and other waste materials with a vacuum cleaner.



BEFORE CARRYING OUT ANY MAINTENANCE OPERATIONS, MAKE SURE THERE ARE NO WHEELS CLAMPED ON THE CHUCK AND THAT ALL SUPPLIES TO THE MACHINE HAVE BEEN DISCONNECTED.

DO NOT BLOW IT WITH COMPRESSED AIR.

- Do not use solvents to clean the pressure regulator.
- The conditioning unit is equipped with an automatic vacuum-operated drain therefore it requires no manual intervention by the operator (see Fig. 25).

Fig. 25

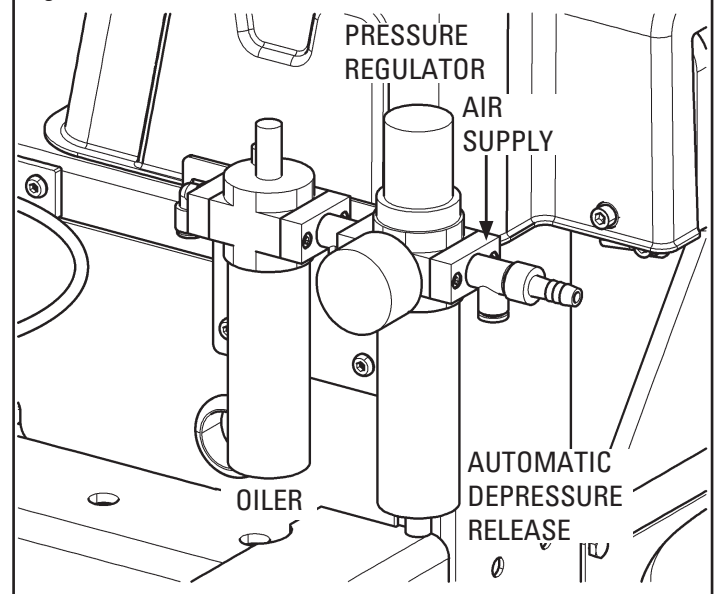



IN ORDER TO ALLOW A LONGER LIFE OF THE FILTER AND OF ALL MOVING PNEUMATIC DEVICES, YOU HAVE TO MAKE SURE THAT THE SUPPLIED AIR IS:

- EXEMPT FROM THE LUBRICATING OIL OF THE COMPRESSOR;
- EXEMPT FROM HUMIDITY;
- EXEMPT FROM IMPURITY.

- Every week and/or when necessary, top up the oil tank using the filler hole provided, closed by a cap or screw, on the lubricator filter.

NOTE: This operation should not be carried out by unscrewing the cup of the lubricator filter.

- The use of synthetic oil might damage the pressure regulator filter.
- Replace worn pieces (tool supports, rubber pads, lever guard, mounting tool) immediately.
- Periodically (preferably once a month) make a complete check on the controls, ensuring that they provide the specified actions.
- Every week check operation of the safety device.
- Periodically (at least each 100 working hours) check the lubricant level into the reduction unit (Fig. 26 ref. 1) removing the plug (Fig. 26 ref. 2) through the spy hole prearranged on the frame.

Fig. 26

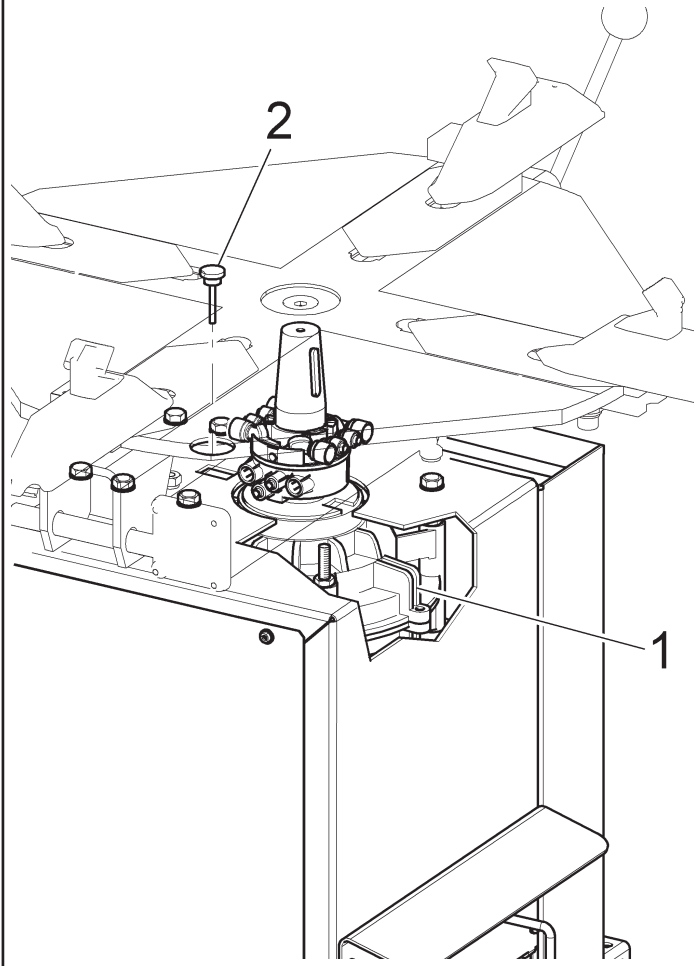

Interventions every 1000 working hours

- Clean and/or replace silencers (Fig. 27 ref. 1):
 1. Undo the four retaining screws and remove the left side of the tyre changer or undo the fastening screws to remove the whole pedal support unit from machine front;
 2. Undo the silencers (Fig. 27 ref. 1) onto the pedal distributor controlling chuck and bead breaker;
 3. Blow compressed air to clean or replace in case of damages referring to spare parts catalogue;
 4. Fit the filters onto their distributors;
 5. Fit the tyre changer pedal support or side and secure with the screws.

Fig. 27

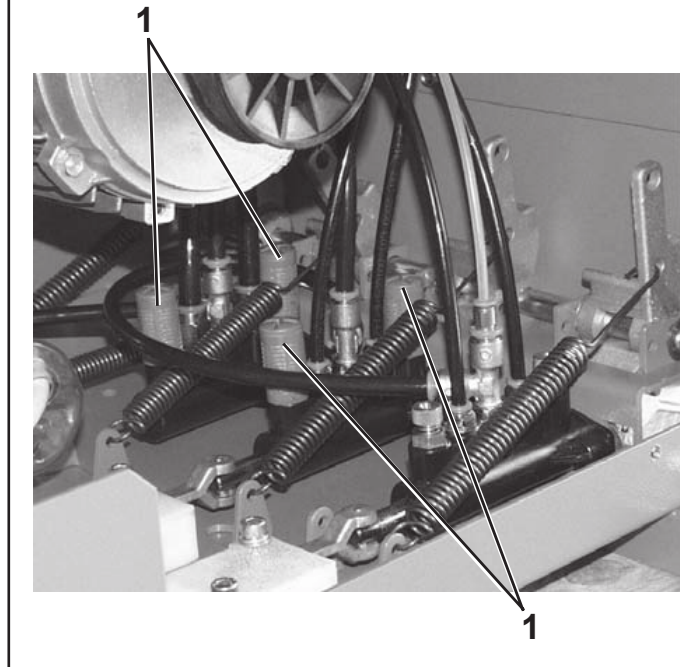

- Check the transmission belt (Fig. 28 ref. 3) for wear or proper tensioning:
1. Undo the four retaining screws and remove tyre changer side panel (Fig. 28 ref. 1);
 2. To tension up the belt (Fig. 28 ref. 3) Turn the screws (Fig. 28 ref. 4) motor support (Fig. 28 ref. 2);
 3. Replace the belt (Fig. 28 ref. 3) if worn out using genuine parts;
 4. Fit the tyre changer side panel before continuing with assembly and disassembly procedure;

Fig. 28

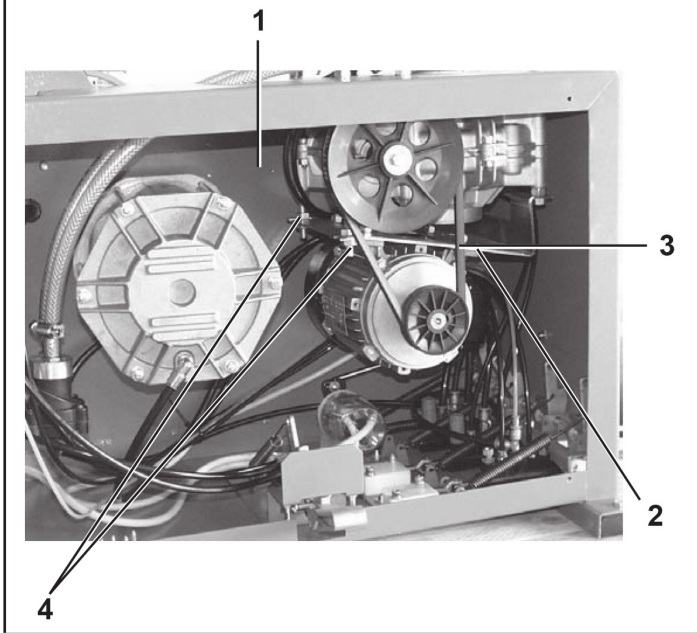

13.1 Lubricants

To grease the chuck movement control gearbox, use ESSO GEAR OIL GX140.

Lubricate slides and screws/nut screws or racks and pinion with a soft brush using lubricant of ESSO GP.



ANY DAMAGE TO THE MACHINE DEVICES RESULTING FROM THE USE OF LUBRICANTS OTHER THAN THOSE RECOMMENDED IN THIS MANUAL WILL RELEASE THE MANUFACTURER FROM ANY LIABILITY.



ANY DAMAGE TO THE MACHINE DEVICES RESULTING FROM THE USE OF LUBRICANTS OTHER THAN THOSE RECOMMENDED IN THIS MANUAL WILL RELEASE THE MANUFACTURER FROM ANY LIABILITY!!

14.0 TROUBLESHOOTING TABLE

Possible troubles which might occur to the tyre-changer are listed below. The manufacturer disclaims all responsibility for damages to people, animals or objects due to improper operation by non-authorized personnel. In case of trouble, call Technical Service Department for instructions on how to service and/or adjust the machine in full safety to avoid any risk of damage to people, animals or objects.

In an emergency and before maintenance on tyre-changer, set the main switch to "0" and lock it in this position.



CONTACT AUTHORIZED TECHNICAL SERVICE
do not try and service alone

Problem	Possible cause	Remedy
The chuck does not work if pedal is pressed.	<ol style="list-style-type: none"> 1. No voltage available. 2. Motor faulty. 3. Safety fuses for machine system blown. 	<ol style="list-style-type: none"> 1. Check that the plug is properly connected and power supply is working. 2. Check for correspondence of electric data of the machine with the mains. 3. Check for proper working conditions. Check connections and parts (motors and switches).
The chuck stops during tyre assembly/disassembly.	Transmission belt slow or worn out.	Check for proper working conditions of the transmission belt. Tension up and/or replace, if necessary.
The chuck does not clamp the rim properly.	<ol style="list-style-type: none"> 1. Clamps worn out. 2. One or more pneumatic cylinders faulty. 	<ol style="list-style-type: none"> 1. Replace clamps. 2. Replace pneumatic cylinder gaskets.
The head gets in contact with the rim during assembly/disassembly.	<ol style="list-style-type: none"> 1. Clamping plate not adjusted or faulty. 2. Chuck locking screw loose. 	<ol style="list-style-type: none"> 1. Adjust or replace the clamping plate. 2. Tighten the screw.
One or more pedals do not return to their original position.	<ol style="list-style-type: none"> 1. Return spring released. 2. Return spring broken. 	<ol style="list-style-type: none"> 1. Fasten the spring. 2. Replace the spring.
Pneumatic controls do not work (chuck locking, bead breaker, post unit tilting and tool clamping).	<ol style="list-style-type: none"> 1. Machine pneumatic system not connected. 2. Air lines clogged. 	<ol style="list-style-type: none"> 1. Check pneumatic connections and supply. 2. Ensure that the air filter is clean and undamaged, if fitted. If no air filter is fitted, remove any dirt into the pneumatic system and then fit a suitable filter. Clean and/or replace the silencers.
Some single pneumatic devices do not work (bead breaker, clamps, post unit tilting device).	Ensure that device and/or distributor seals are not damaged.	Call for technical assistance. 

15.0 TECHNICAL DATA

15.1 *Technical electrical data*

		For 1-Ph adjustable speed version	For 3-Ph 2-speed versions
Motor power (kW)		0.75	0.8-1.1
Power supply	Voltage (V)	240	400
	Phases	1	3
	Frequency (Hz)	50-60	50
Chuck rotation speed (rev/min)		0-16	6.5/13

15.2 *Technical mechanical data*

		For versions with 10"-22" chuck	For version with 10"-24" chuck
Max. tyre diameter (mm)		1050 (41")	
Tool working span (inches)		10 - 22	10 - 24
Max. rim width (inches)		12	
Max. torque to chuck (Nm)		1200	
Bead-breaker cylinder power at 10 bar (N)		30000	
Self-centring chuck lock: external (inches)		10 - 22	10 - 24
Self-centring chuck lock: internal (inches)		12 - 24.5	12 - 26.5
Operating pressure (bar)		8 - 10	

		For version without tubeless inflation	For versions with tubeless inflation
Weight (Kg)		214	234

15.3 Dimensions

Fig. 29

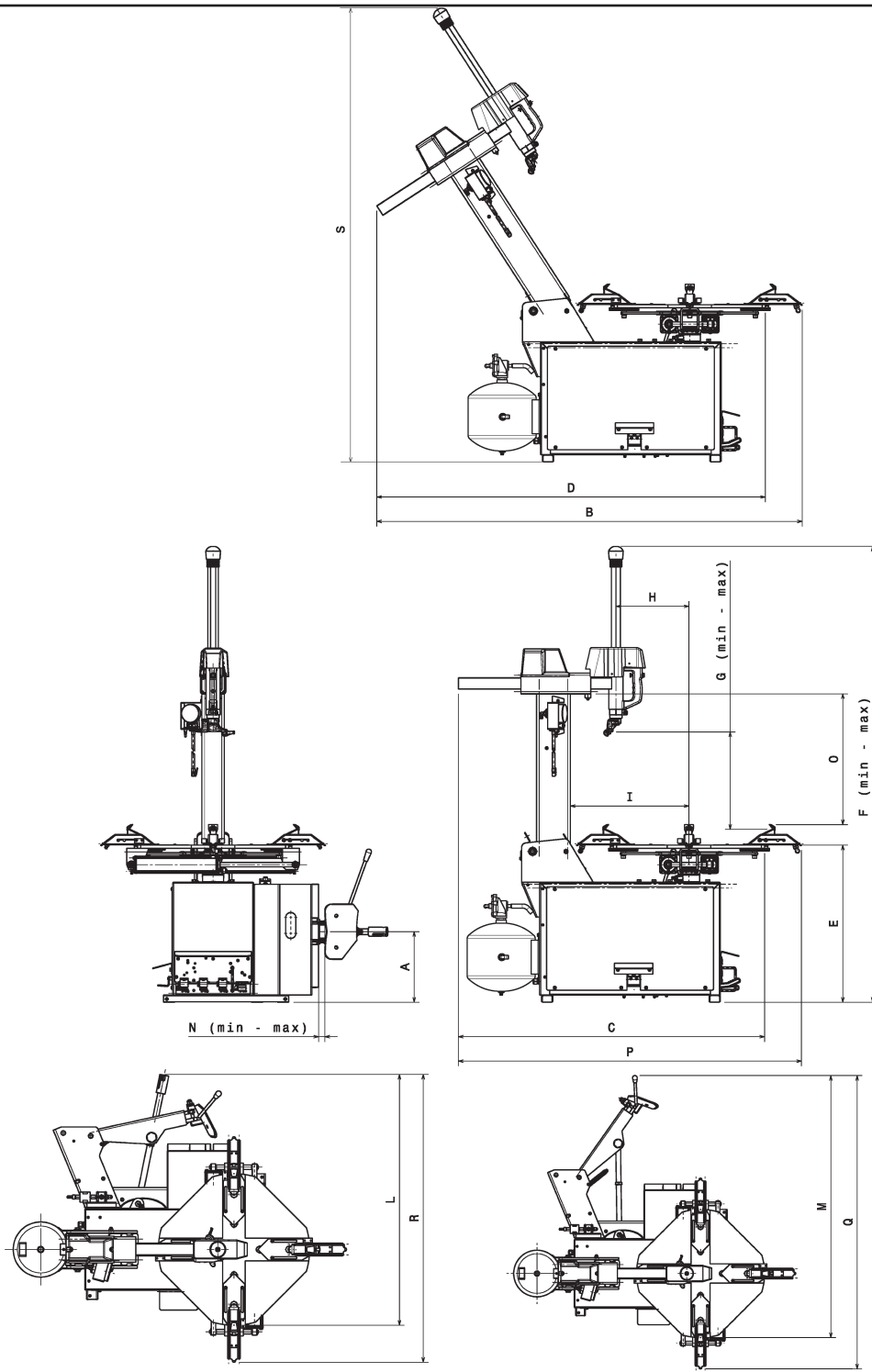

Model	A	B	C	D	E	F		G	H	I	L	M	N		O	P	Q	R	S
	(mm)	(mm)	(mm)	(mm)	(mm)	(mm)	(mm)	(mm)	(mm)	(mm)	(mm)	(mm)	(mm)	(mm)	(mm)	(mm)	(mm)	(mm)	(mm)
	(inches)	(inches)	(inches)	(inches)	(inches)	(inches)	(inches)	(inches)	(inches)	(inches)	(inches)	(inches)	(inches)	(inches)	(inches)	(inches)	(inches)	(inches)	(inches)
						Min.	Max.	Max.					Min.	Max.					
1-Ph adjustable-speed with tubeless inflation	310 12.2	1809 71.22	1323 52.09	1686.5 66.4	664 26.14	1529 60.2"	1796 70.71	287 11.3	311.5 12.26	525 20.67	903 35.55	1182 46.54	50 1.97	359 14.13	492 19.37	1449 57.05	1303.5 51.32	1025 40.35	1950 76.77
3-Ph 2-speed with 24" chuck tubeless inflation	310 12.2	1832 72.13	1306 51.42	1710 67.32	664 26.14	1529 60.2	1796 70.71	287 11.3	311.5 12.26	525 20.67	963 37.91	1242 48.9	50 1.97	359 14.13	492 19.37	1432 56.38	1327 52.24	1048 41.26	1950 76.77

16.0 STORING

If storing for long periods (6 months or longer) disconnect the main power supply and take measures to protect the machine from dust build-up. Lubricate parts that could be damaged from drying out. When putting the machine back into operation replace the rubber pads and the mounting tool. Moreover, carry out a verification of machine perfect functioning.

17.0 SCRAPPING

When the decision is taken not to make further use of the machine, it is advisable to make it inoperative by removing the connection pressure hoses. The machine is to be considered as special waste and should be dismantled into homogeneous parts. Dispose of it in accordance with current legislation.

Instructions for the correct management of waste from electric and electronic equipment (WEEE) according to the Italian legislative decree 49/14 and subsequent amendments.

In order to inform the users on the correct way to dispose the product (as required by the article 26, paragraph 1 of the Italian legislative decree 49/14 and subsequent amendments), we communicate what follows: the meaning of the crossed dustbin symbol reported on the equipment indicates that the product must not be thrown among the undifferentiated rubbish (that is to say together with the "mixed urban waste"), but it has to be managed separately, to let the WEEE go through special operations for their reuse or treatment, in order to remove and dispose safely the waste that could be dangerous for the environment and to extract and recycle the raw materials to be reused.

Fig. 30

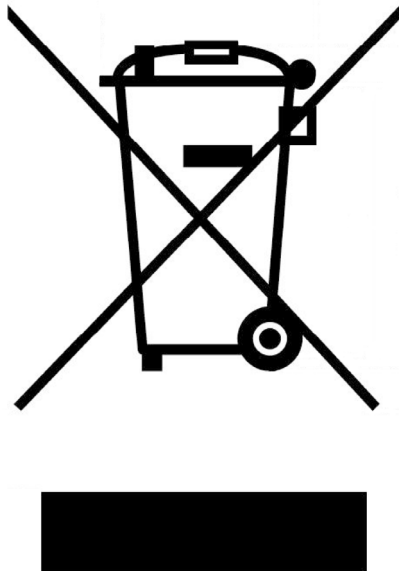

18.0 REGISTRATION PLATE DATA

The validity of the Conformity Declaration enclosed to this manual is also extended to products and/or devices the machine model object of the Conformity Declaration can be equipped with. Said plate must always be kept clean from grease residues or filth generally.

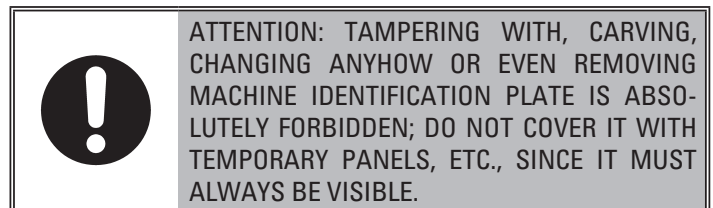

WARNING: Should the plate be accidentally damaged (removed from the machine, damaged or even partially illegible) inform immediately the manufacturer.

19.0 FUNCTIONAL DIAGRAMS

Here follows a list of the machine functional diagrams.

Installer: Please return this booklet to literature package, and give it to the owner/operator.

Thank You

Trained Operators and Regular Maintenance Ensures Satisfactory Performance of Your Wheel Service Equipment.

Contact Your Nearest Authorized Rotary Wheel Service Equipment Parts Distributor for Genuine Replacement Parts. See Literature Package for Parts Breakdown.

Rotary World Headquarters

2700 Lanier Drive
Madison, IN 47250, USA
www.rotarylif.com

North America Contact Information

Tech. Support:
p 800.445.5438
f 800.578.5438
e userlink@rotarylif.com
Sales:
p 800.640.5438
f 800.578.5438
e userlink@rotarylif.com

World Wide Contact Information

World Headquarters/USA: 1.812.273.1622
Canada: 1.905.812.9920
European Headquarters/Germany: +49.771.9233.0
United Kingdom: +44.178.747.7711
Australasia: +60.3.7660.0285
Latin America / Caribbean: +54.3488.431.608
Middle East / Northern Africa: +49.771.9233.0

© Vehicle Service Group™™™

Printed in U.S.A., All Rights Reserved. Unless otherwise indicated, ROTARY, and all other trademarks are property of Dover Corporation and its affiliates.

