

Installation Instructions

Capacity 10,000 lbs. (4,536kg.)
(400 Series Lift)

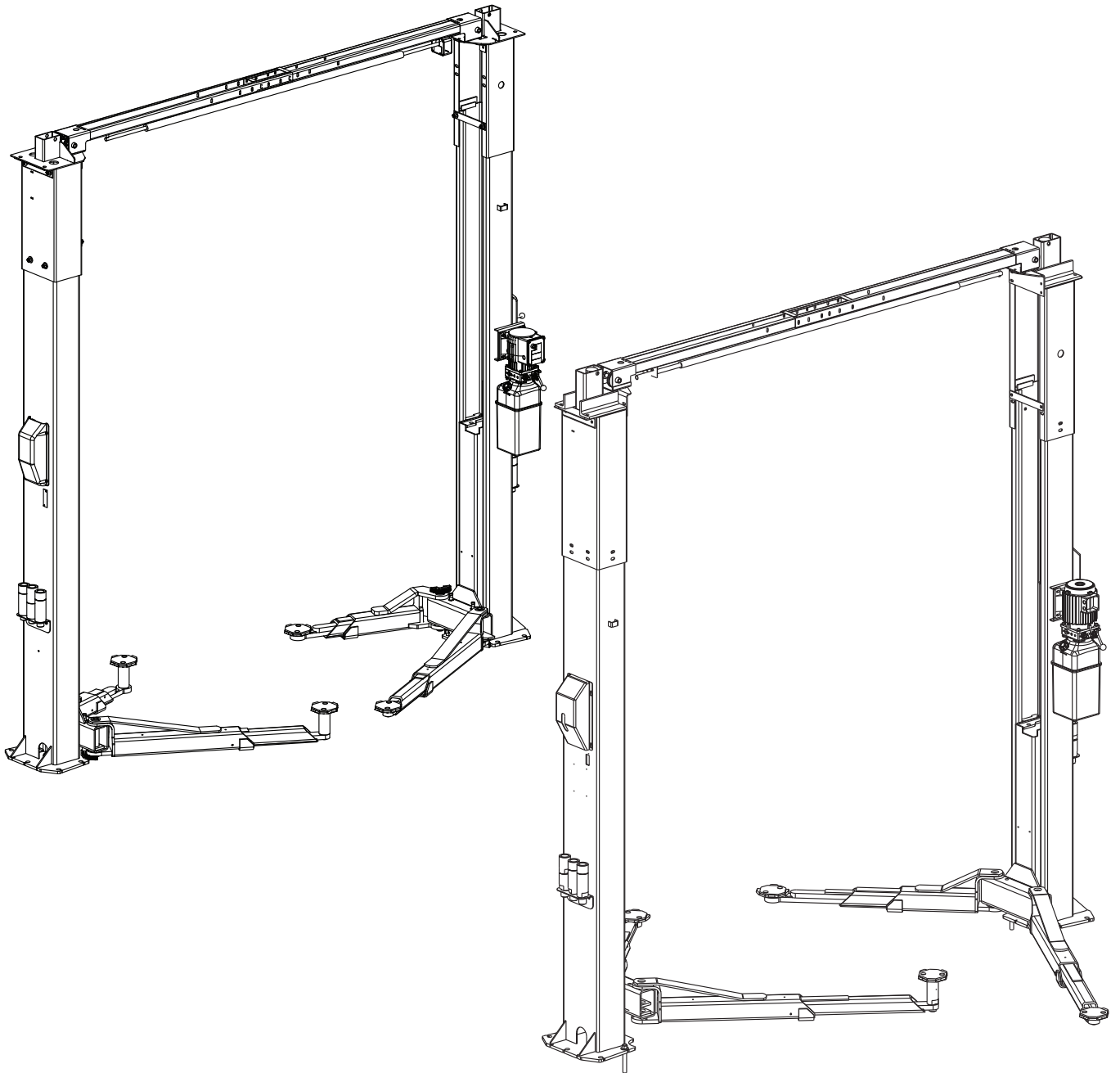

▲ IMPORTANT Reference ANSI/ALI ALIS, Safety Requirements for Installation and Service of Automotive Lifts before installing lift.

OPERATING CONDITIONS
Lift is not intended for outdoor use
and has an operating ambient temperature
range of
41°-104°F (5°-40°C)

LP60026

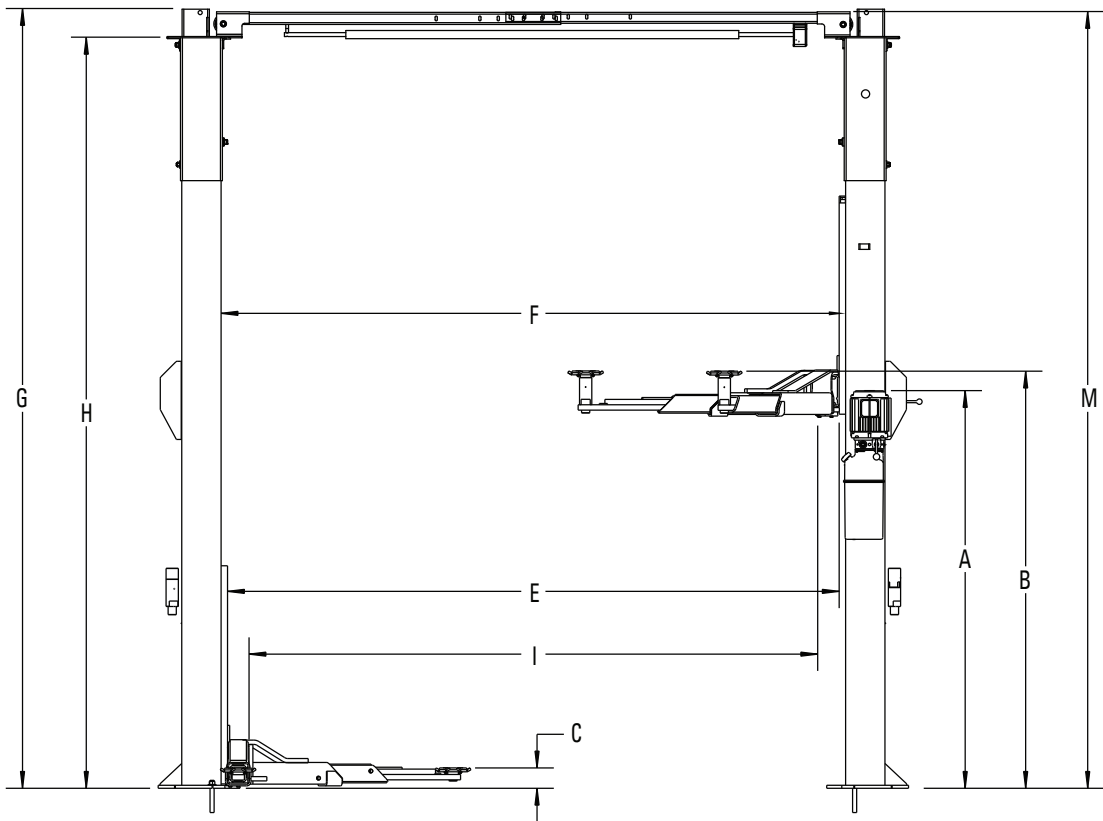

Fig. 1a

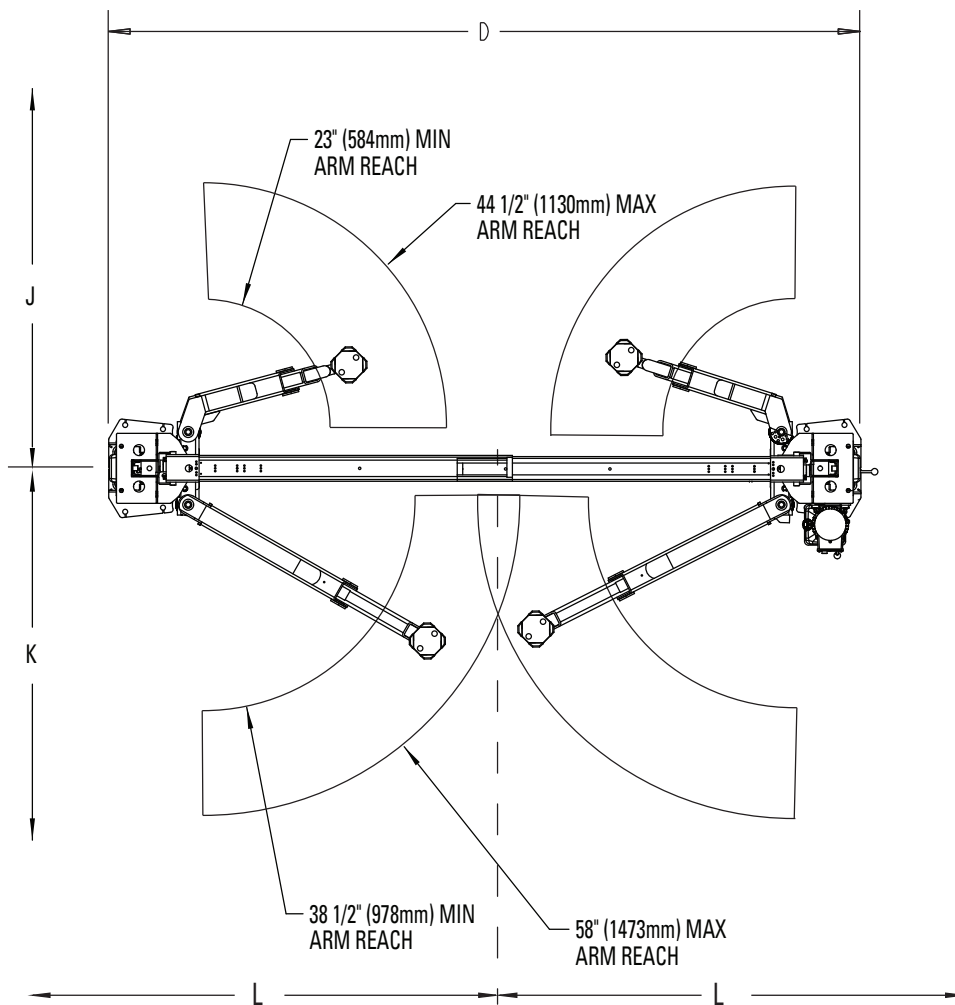

Fig. 1b

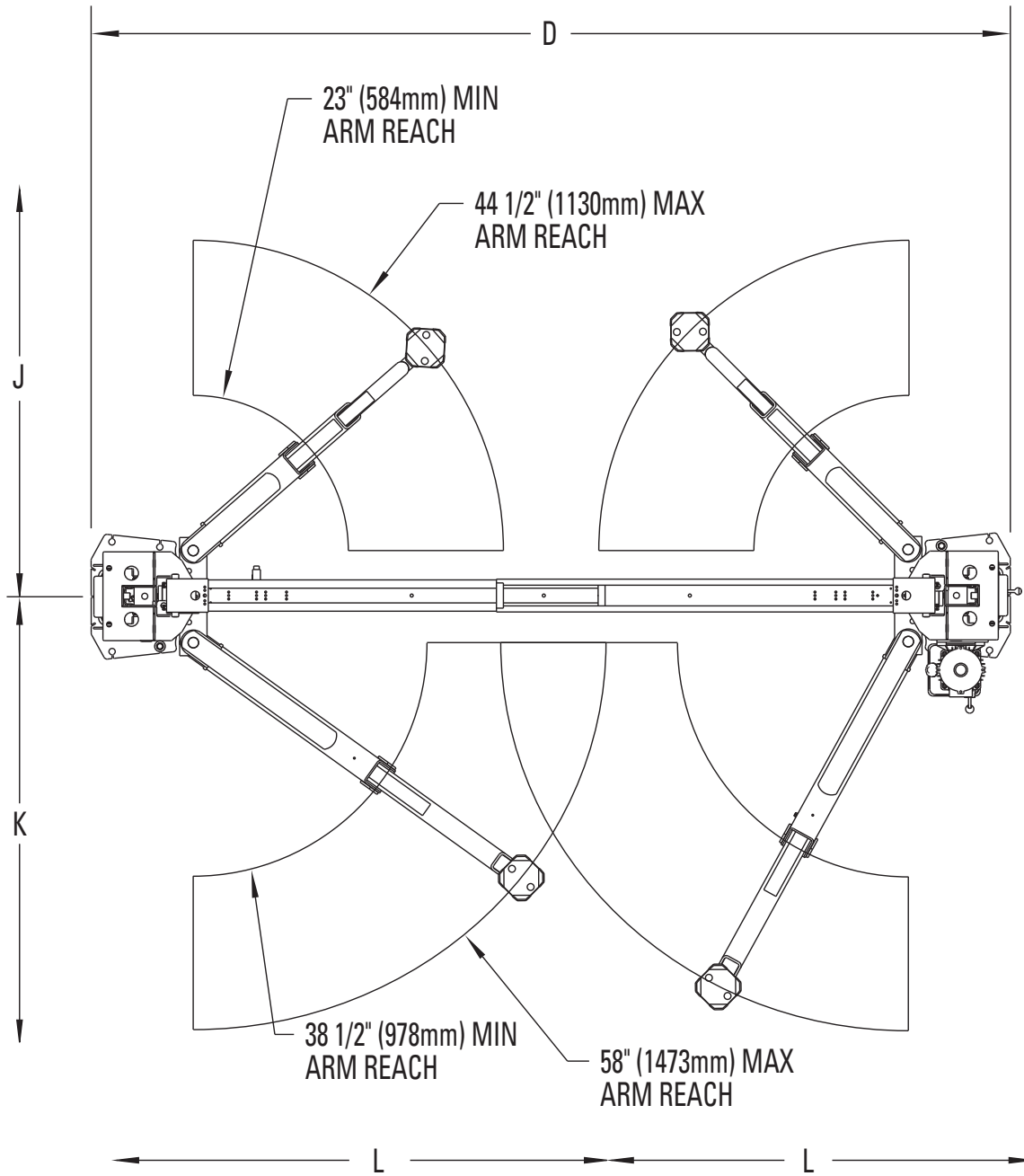

Fig. 1c

1. Lift Location: Use architects plan when available to locate lift. Fig. 1a & Fig. 1b shows dimensions of a typical bay layout.

⚠ WARNING DO NOT install this lift in a pit or depression due to fire or explosion risks.

A	POWER UNIT HEIGHT	72 1/2" (1842mm)
B	LIFTING HEIGHT W/ 5" (127mm) EXTENSION	76 1/8" (1934mm) W/ 67 1/2" (1715mm) STROKE
C	MIN. LIFT HEIGHT	3 5/8" (92mm)
	MIN. LIFT HEIGHT W/ 1 3/4" (44mm) ADAPTER	5 3/8" (137mm)
	MIN. LIFT HEIGHT W/ 3 1/2" (89mm) ADAPTER	7 1/8" (181mm)
	MIN. LIFT HEIGHT W/ 5" ADAPTER	8 5/8" (219mm)
D	OVERALL FLOOR WIDTH	137" (3480mm)
	OVERALL FLOOR WIDTH (NARROW)	131" (3327mm)
E	WIDTH BETWEEN CARRIAGES	113" (2870mm)
	WIDTH BETWEEN CARRIAGES (NARROW)	107" (2718mm)
F	INSIDE COLUMNS	115" (2921mm)
	INSIDE COLUMNS (NARROW)	109" (2769mm)
G	HEIGHT OVERALL	143 1/2" (3645mm)
	MIN. FLOOR CEILING HEIGHT	144" (3658mm)
	MIN. FLOOR CEILING HEIGHT (LOW HEIGHT)	138 1/2" (3518mm)
H	FLOOR TO OVERHEAD SWITCH	137 5/8" (3496mm)
	FLOOR TO OVERHEAD SWITCH (LOW HEIGHT)	131 5/8" (3343mm)
I	DRIVE THRU CLEARANCE	105" (2667mm)
	DRIVE THRU CLEARANCE (NARROW)	99" (2515mm)
J	MINIMUM TO NEAREST OBSTRUCTION	132" (3353mm)
K	MINIMUM TO NEAREST OBSTRUCTION	156" (3962mm)
L	MINIMUM TO NEAREST OBSTRUCTION	72" (1829mm)
M	OVERHEAD HEIGHT	143" (3632mm)
	OVERHEAD HEIGHT (LOW HEIGHT)	137" (3480mm)

NOTES:

- 1.) ALL HEIGHT DIMENSIONS ARE WITHOUT LEVELING SHIMS.
- 2.) STANDARD HEIGHT LIFT SHOWN.
- 3.) ANCHORING SYSTEM TESTED TO ANSI/ALI ALCTV 2006.

LIFT CAPACITY	10,000 LBS. (4,536 kg.)
LIFTING SPEED (RISE TIME)	APPROXIMATELY 45 SECONDS UNLOADED APPROXIMATELY 51 SECONDS AT RATED CAPACITY
MOTOR RATING OPTIONS	3 PHASE 208-230/460V 50-60Hz 17/8.5-14/8 AMPS SINGLE PHASE 208-230V 60Hz 16 AMPS SINGLE PHASE 208-230V 50Hz 15 AMPS
WEIGHT	1505 LBS. (683 kg.)
MECHANICAL SAFETY LOCKS	AUTOMATIC ALL POSITIONS
MECHANICAL SAFETY RELEASE	MANUAL ALL BOTH COLUMNS
SWING ARM RESTRAINTS	AUTOMATIC ENGAGEMENT ABOVE 2 1/2" (64mm)
HYDRAULIC SAFETY SYSTEM	AUTOMATIC ALL POSITIONS
CYLINDERS	TWO, ONE PER COLUMN
CARRIAGE BEARINGS	EIGHT PER CARRIAGE, UHMW
SYNCHRONIZATION	EQUALIZATION CABLES
MIN. BAY SIZE	12' X 24' (3658 X 7315mm) VERIFY WITH SITE PLAN & SERVICE VEHICLES

2. Latch Cable Guides: Install the latch cable conduit guide brackets to column extensions with (1) 1/4" - 20NC x 1" HHCS and 1/4" - 20NC Flanged Locknuts, HHCS should go through hole nearest the edge as shown, Fig. 2.

3. Cylinder Fitting: Prior to standing up lift columns, install the 90° elbow fitting to the cylinder and equalizer cable to the bottom of the carriage Fig 3. Remove plug from the top of the cylinders and install the appropriate fittings per Fig. 12a.

CAUTION Over tightening will damage fitting resulting in fluid leakage.

4. Equalizer Cables

- A.) First, run a cable end up through the small hole in the lower tie-off plate. Fig. 15.
- B) Push the cable up until the stud is out of the carriage top opening.
- C) Run a nylon insert locknut onto the cable stud so 1/2" (13mm) of the stud extends out of the locknut.
- D) Pull the cable back down, Fig. 3.
- E) Run cable around the lower sheave, then up and out of the top of the column.

5. Tie Bar: Attach tie bar to column with (2) 1/2" - 13x1-3/4" HHCS, (2) 1/2" Flat Washer, and (2) 1/2"-13 Nylon Locknut, Fig. 3.

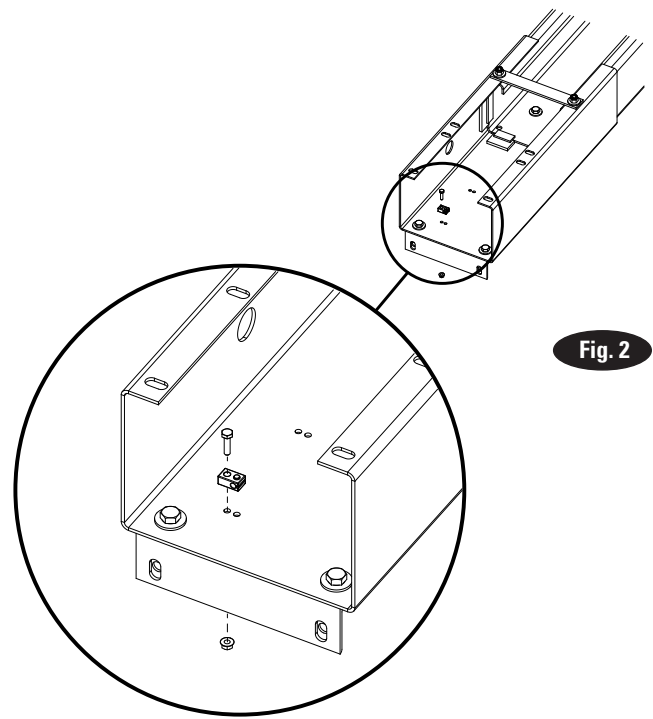

Fig. 2

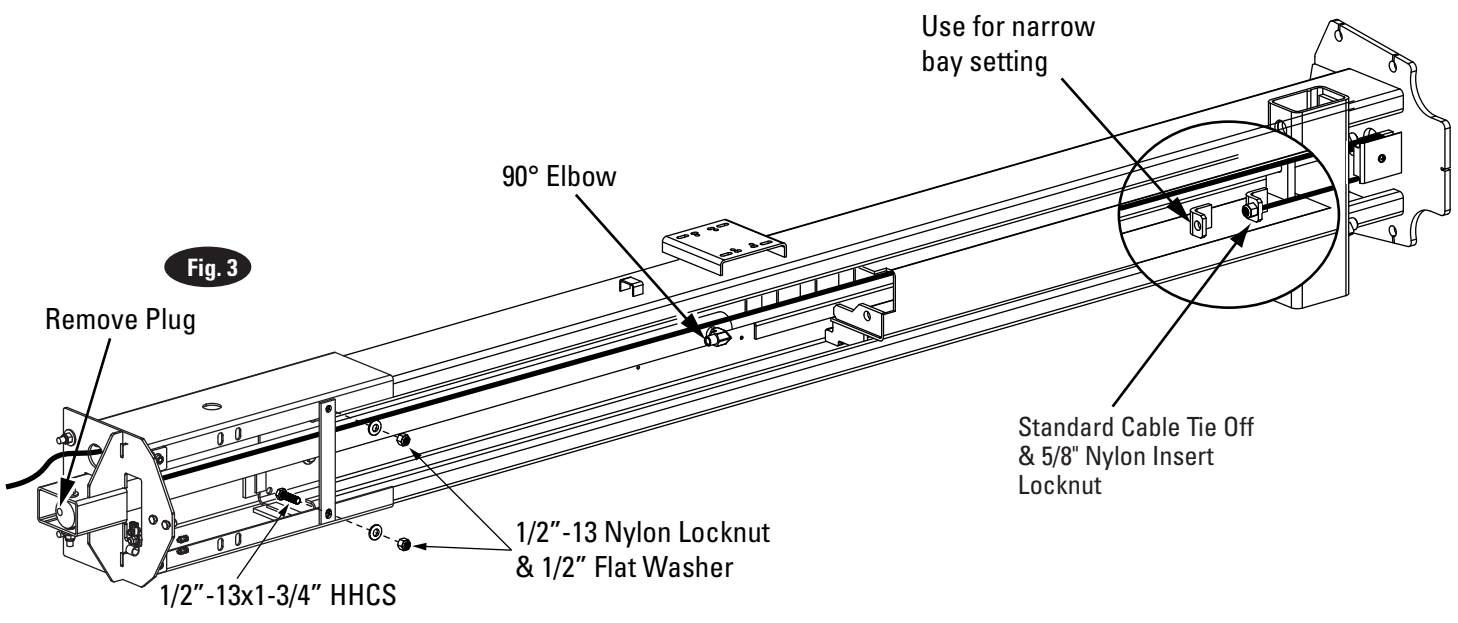

Fig. 3

6. Lift Setting: Position columns in bay using dimensions shown in Fig. 1a & Fig. 1b. Place column with power unit mounting bracket on vehicle passenger side of lift. Both column base plate backs must be square on center line of lift. Notches are cut into each base plate to indicate center line of lift. Use appropriate equipment to raise carriage to first latch position. Be sure locking latch is securely engaged.

7. Concrete and Anchoring:

Drill (10) 3/4" dia. holes in concrete floor using holes in column base plate as a guide. See Fig. 5 for hole depth, hole spacing, and edge distance requirements.

CAUTION DO NOT install on asphalt or other similar unstable surfaces. Columns are supported only by anchors in floor.

IMPORTANT Using the horse shoe shims provided, shim each column base until each column is plumb. If one column has to be elevated to match the plane of the other column, full size base shim plates should be used (Reference FA9116 Shim Kit). Recheck columns for plumb. Tighten anchor bolts to an installation torque of 110 ft-lbs. (149 Nm). Shim thickness MUST NOT exceed 1/2" (13mm) when using the 5-1/2" (140mm) long anchors provided with the lift, Fig. 4. Adjust the column extensions plumb.

If anchors do not tighten to 110 ft-lbs. (149 Nm) installation torque, replace concrete under each column base with a 4' x 4' x 6" (1219 x 1219 x 152mm) thick 3000 PSI (20684 kPa) minimum concrete pad keyed under and flush with the top of existing floor. Let concrete cure before installing lifts and anchors.

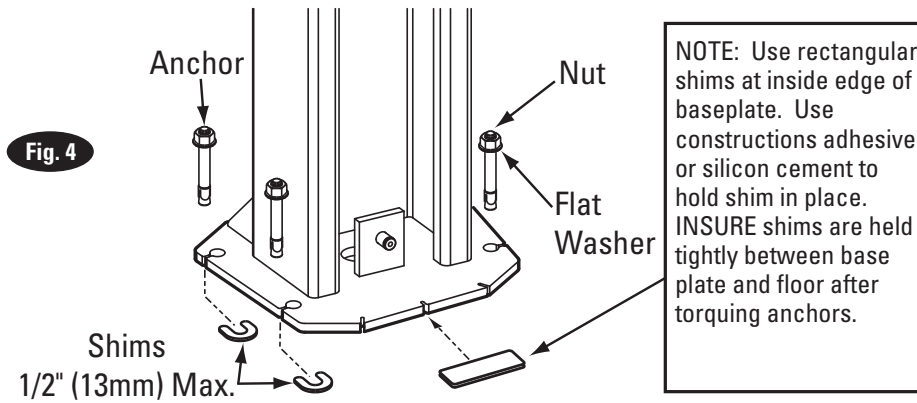

NOTE: If more than 2 horse shoe shims are used at any of the column anchor bolts, pack non-shrink grout under the unsupported area of the column base. Insure shims are held tightly between the baseplate and floor after torquing anchors.

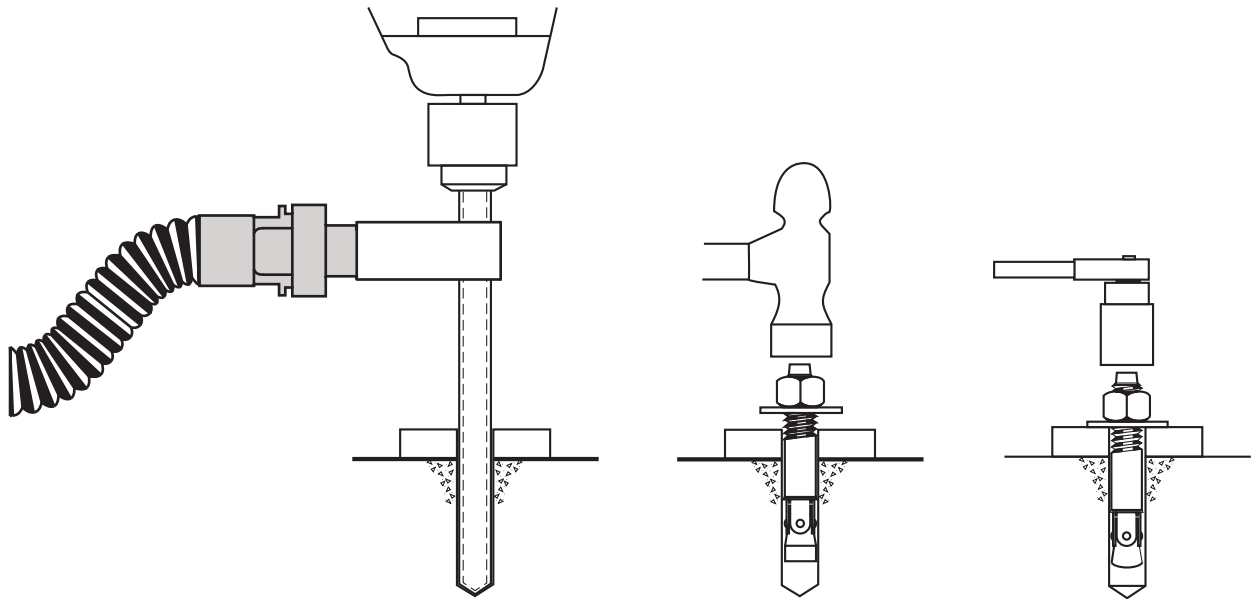

Drill holes using 3/4" carbide tipped masonry drill bit per ANSI B212.15-1994 (R2000). Construction dust collected per OSHA 29 CFR 1926.1153.

Run nut down just below impact section of bolt. Drive anchor into hole until nut and washer contact base.

Tighten nut with Torque wrench to 110 ft.-lbs. (149 Nm).

Fig. 5

7-10K 2-Post Lift Anchor Installation Reference Guide

Anchor:	Min Concrete Thickness	Min Edge Distance	Min Anchor Embedment	Installation Anchor Torque Ft-lbs	Min Concrete PSI Strength - For All Standards	Concrete pad Size If Concrete Does Not Meet Requirements	Maintenance Torque Values	SEISMIC
Hilti Kwik Bolt III (3/4" x 5-1/2")	4-1/4" (108mm)	3-3/8" (86mm)	3-1/4" (83mm)	110 (149 Nm)	3000 (20684 kPa)	4'x4'x6" (1219 x 1219 x 152mm)	65 (88 Nm)	Varies by location consult with your structural engineer and manufacturer's representative.
Hilti HY200 (with HAS threaded rod)	6-7/16" (164mm)	1-3/4" (45mm)	4-1/2" (115mm)	100 (149 Nm) / less than 3-3/4" (95mm) edge distance use Torque Value of 30 Ft-lbs (41 Nm)	3000 (20684 kPa)	4'x4'x6" (1219 x 1219 x 152mm)	N/A	
Hilti HY200 (with HAS threaded rod)	5-1/4" (134mm)	3" (77mm)	3-1/2" (89mm)	100 (149 Nm) / less than 3-3/4" (95mm) edge distance use Torque Value of 30 Ft-lbs (41 Nm)	3000 (20684 kPa)	4'x4'x6" (1219 x 1219 x 152mm)	N/A	

***The supplied concrete fasteners meet the criteria of the American National Standard "Automotive Lifts - Safety Requirements for Construction, Testing, and Validation" ANSI/ALI ALCTV-2011, and the lift owner is responsible for all charges related to any additional anchoring requirements as specified by local codes. Contact customer service for further information at: 800.640.5438**

8. Overhead Assembly: Fig. 7: Adjust overhead to appropriate dimension. Install (4) M10-1.5 x 20mm HHCS & M10-1.5 Flanged Locknuts, do not tighten. Slide Switch Box, Fig. 6, over switch bar ensuring knock out holes face the power unit column. Use (2) 1/4"-20NC x 3/4" lg. HHCS, 1/4" Flat Washer, and 1/4"-20NC Nuts to mount switch box to overhead, Fig. 7.

Insert 1/4"-20NC x 2 3/4" HHCS through pivot hole in end of switch bar. Insert opposite end of bar through slot in switch mounting bracket. Then secure HHCS and Switch Bar to overhead as shown, Fig. 7, using (2) 3/4" (19mm) spacers and 1/4"-20NC Locknut. Tighten Hex bolt leaving 1/16" (1.6mm) gap between the spacer and the overhead assembly.

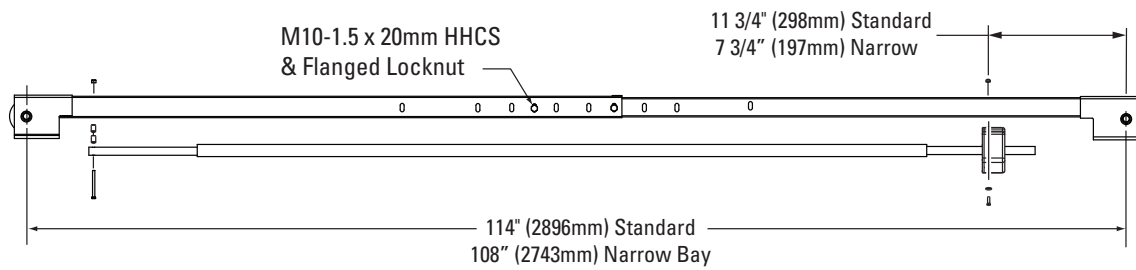
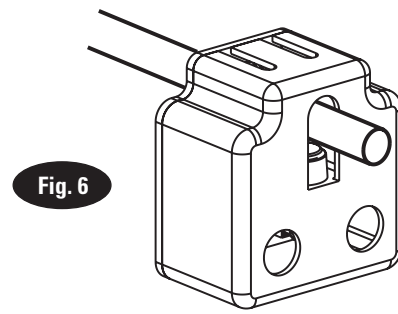
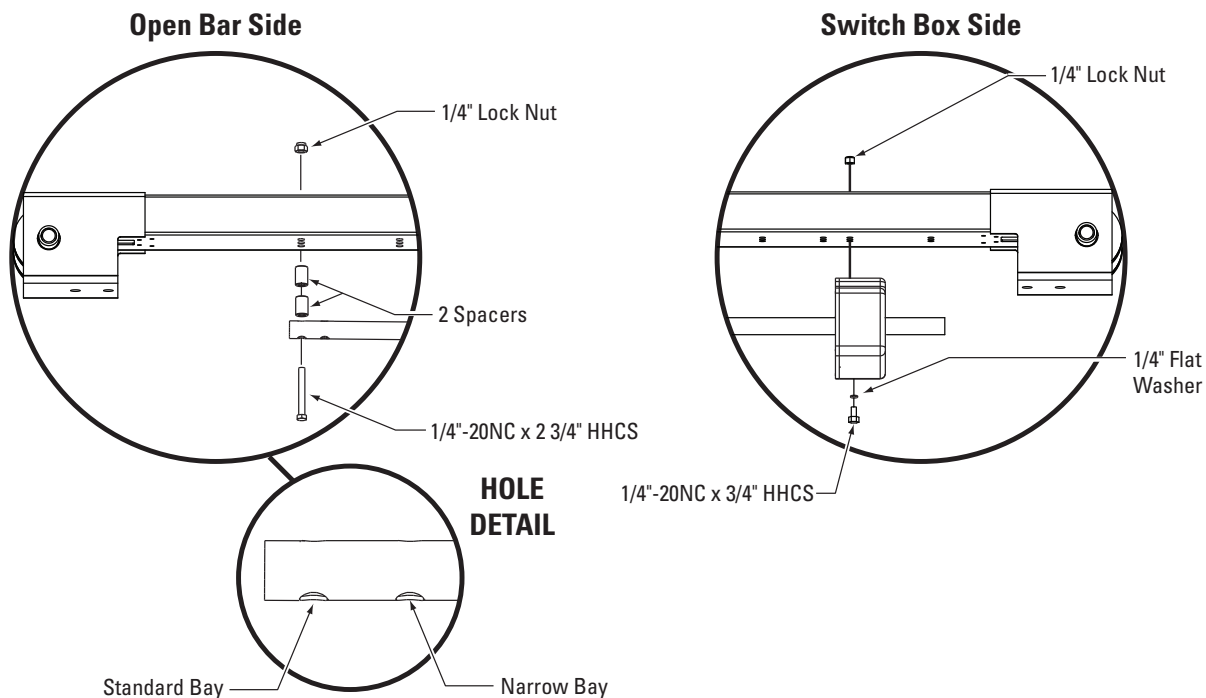

Fig. 7

Hardware Detail For Overhead Assembly



9. Overhead Installation: Install overhead assembly to Mounting Bracket with (4) M10-1.5 x 20mm HHCS, and (4) M10-1.5 Flanged Locknut on both columns, Fig. 8. Tighten bolts at center of overhead assembly.

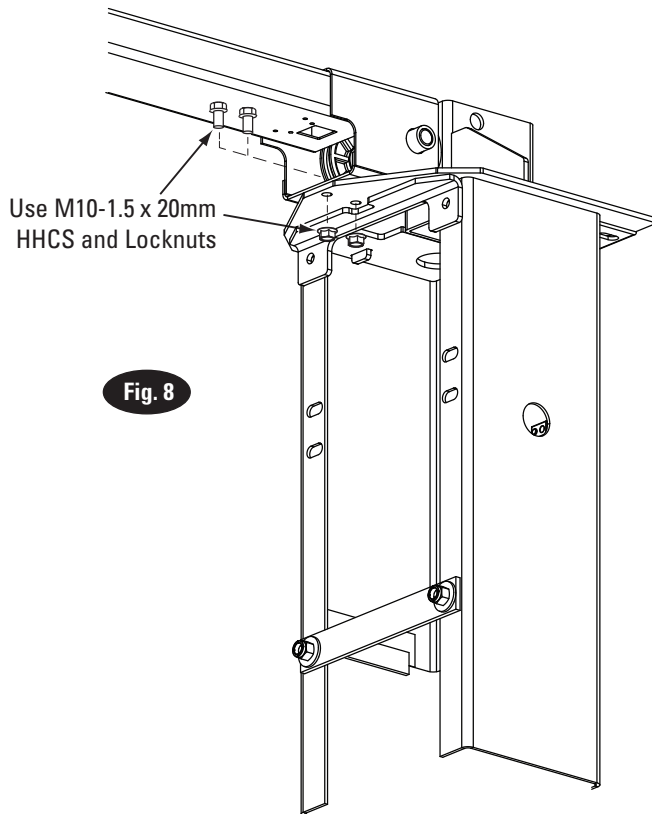

Fig. 8

Overhead Installation Low Height: Install overhead assembly using TP10-3000Kit. Mount the overhead brackets using the lower extension slots, Fig. 9. The low height option allows the overhead to be 6" (152mm) lower than the standard height. See Fig. 9a below for ceiling dimensions required for low height setting.

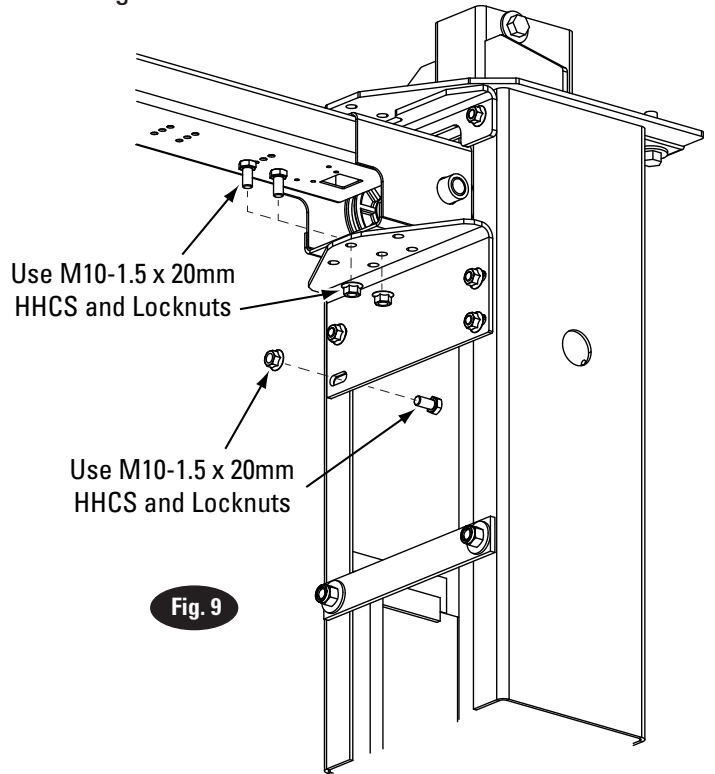

Fig. 9

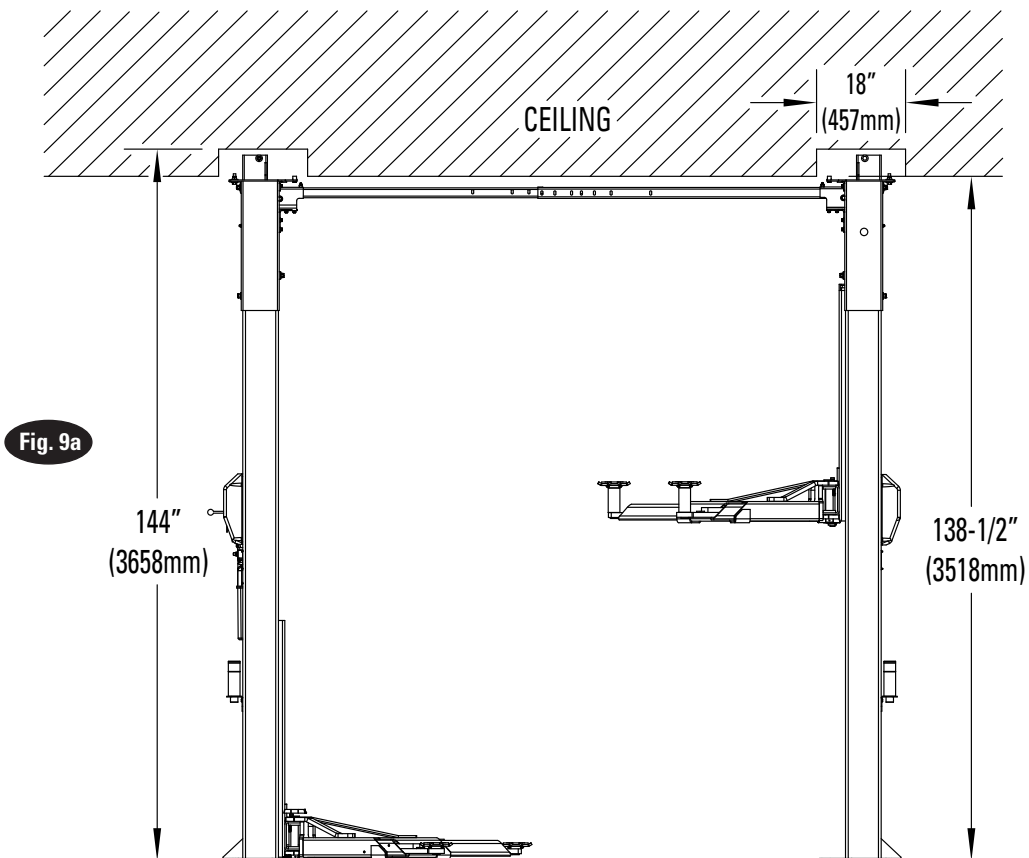

Fig. 9a

10. Power Unit: First install a star washer onto all of the (4) 5/16" -18NC x 1-1/2" HHCS. This is very important for grounding. Put the (4) 5/16" -18NC x 1-1/2" HHCS thru holes in power unit bracket, Fig. 10. Mount unit with motor up to column bracket and install (4) 5/16" star washers and 5/16" Nuts. Install and hand tighten fitting to pump until O-ring is seated. Continue to tighten the locknut until the nut and washer bottom out against the pump manifold.

NOTE: You may still be able to rotate the fitting. This is acceptable unless there is seepage at the O-ring. If so, slightly tighten the locknut.

CAUTION Over tightening locknut may tear O-ring or distort threads in pump manifold outlet.

11. Hoses: Clean adapters and hose. Inspect all threads for damage and hose ends to be sure they are crimped, Fig. 12a & 16a. Install hose and hose clamps, Fig. 11 & Fig. 16a.

Flared Fittings Tightening Procedure

1. Screw the fittings together finger tight. Then, using the proper size wrench, rotate the fitting 2-1/2 hex flats.

IMPORTANT Flare seat **MUST NOT** rotate when tightening. Only the nut should turn.

2. Back the fitting off one full turn.

3. Again tighten the fittings finger tight; then using a wrench, rotate the fitting 2-1/2 hex flats. This will complete the tightening procedure and develop a pressure tight seal.

CAUTION Over tightening will damage fitting resulting in fluid leakage.

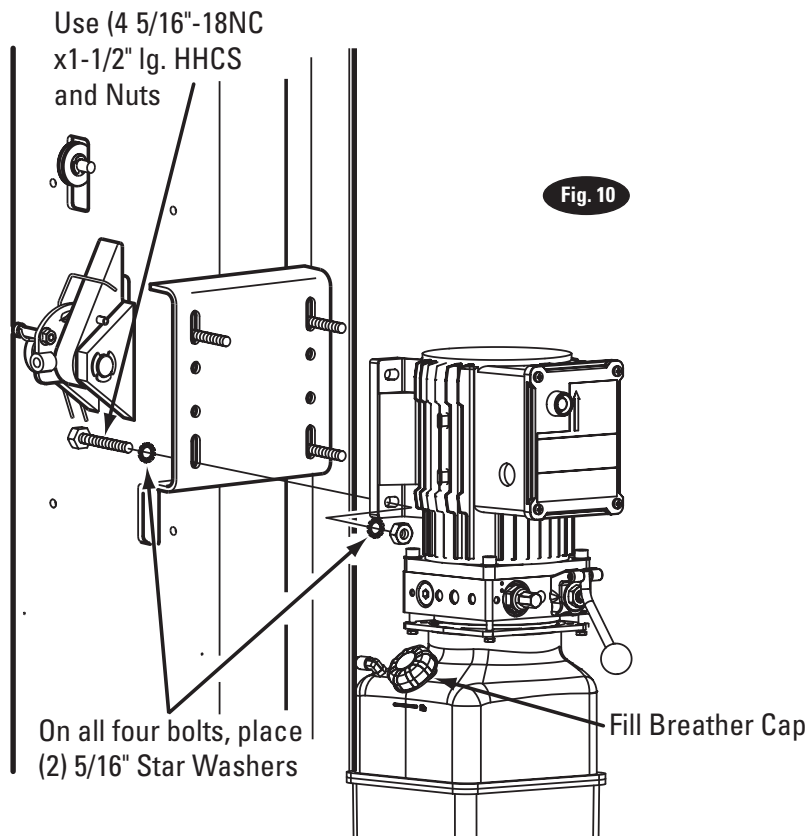

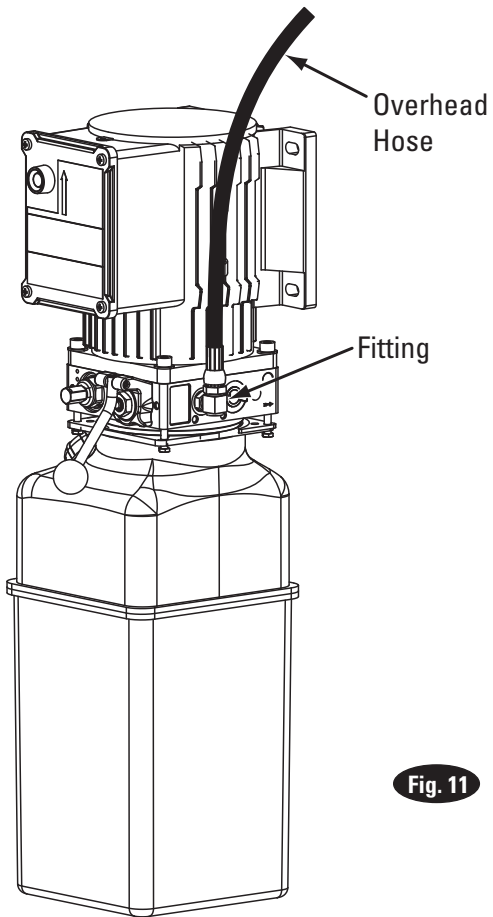

Fig. 11

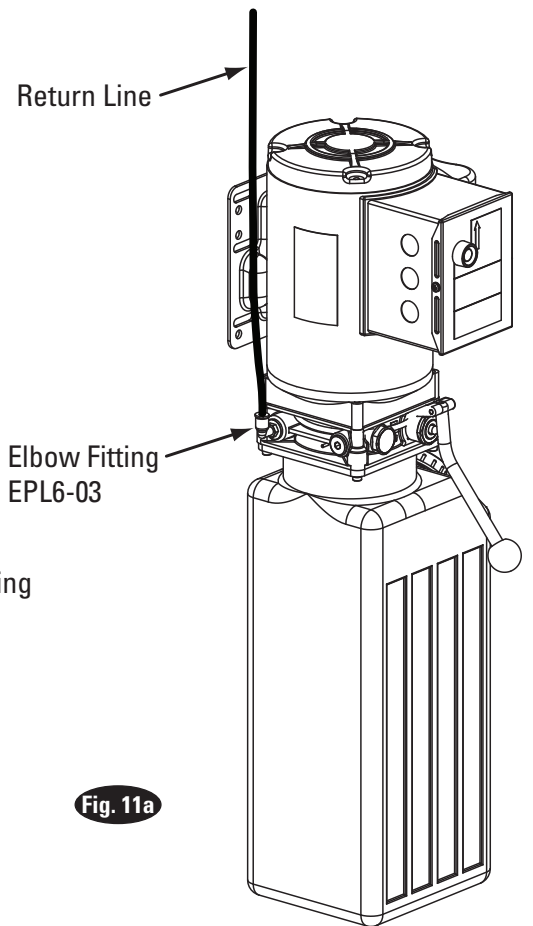
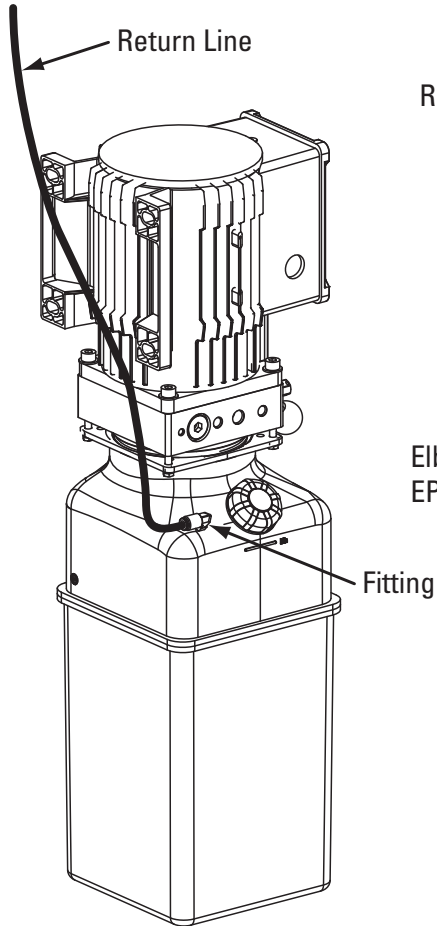

Fig. 11a

Adapter & Hose Installation

1. Before installing the hoses into the lift, attach the Overhead hose Pc. (3) and Cylinder hose Pc. (4) to the "T" fitting Pc. (6) as shown in Figure 12b.
2. Route the assembled hose through the overhead but do not attach to either cylinder.
3. Route the Power Unit hose Pc. (5) through the column hole and attach it to the "T" fitting.

IMPORTANT: Before you connect the power unit hose you must tuck the hoses and union tee behind the cylinder to give you room to complete installation, Fig 12b.

4. Place the assembled "T" fitting behind the cylinder and connect the hoses to the two cylinder ends and the Power Unit.
5. Take up the slack in the Power Unit side cylinder hose and wire tie the "T" fitting tightly to the power unit side cylinder.
6. Secure each hose as needed.
7. Run return line from elbow Pc. (8) to tee Pc. (9). The return line then runs outside of column down and connects to the power unit, Fig. 12a.
8. Verify hydraulic return line fitting is located on fluid tank, Fig. 11. If not, install included return line fitting to power unit, Fig. 11a.

NOTE: Overhead hose goes over top end of overhead assembly, Fig. 12a, 12c, Fig. 17a, & Fig. 17b.

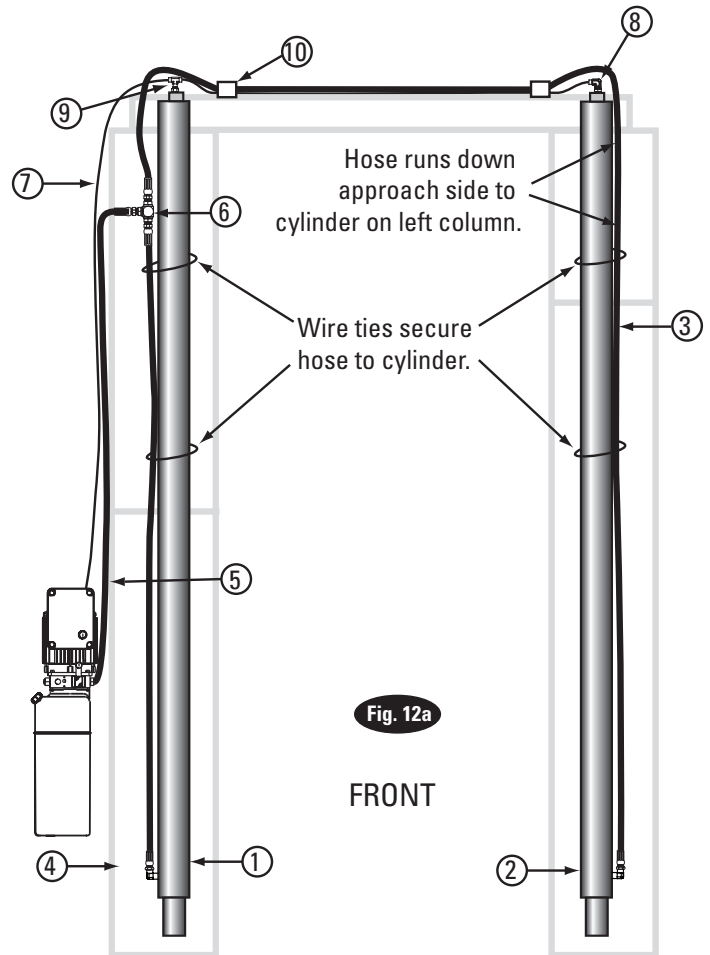

ITEM	QTY.	DESCRIPTION
1	1	Power Unit Side Cylinder
2	1	Passenger Side Cylinder
3	1	Passenger Side Hose
4	1	Cylinder Hose
5	1	Power Unit Hose
6	1	3/8" Branch Tee
7	1	Return Line
8	1	1/4" Elbow
9	1	1/4" Branch Tee
10	2	Hose Clamps
	2	M10-1.5 x 20mm HHCS
	2	M10-1.5 Flanged Locknuts

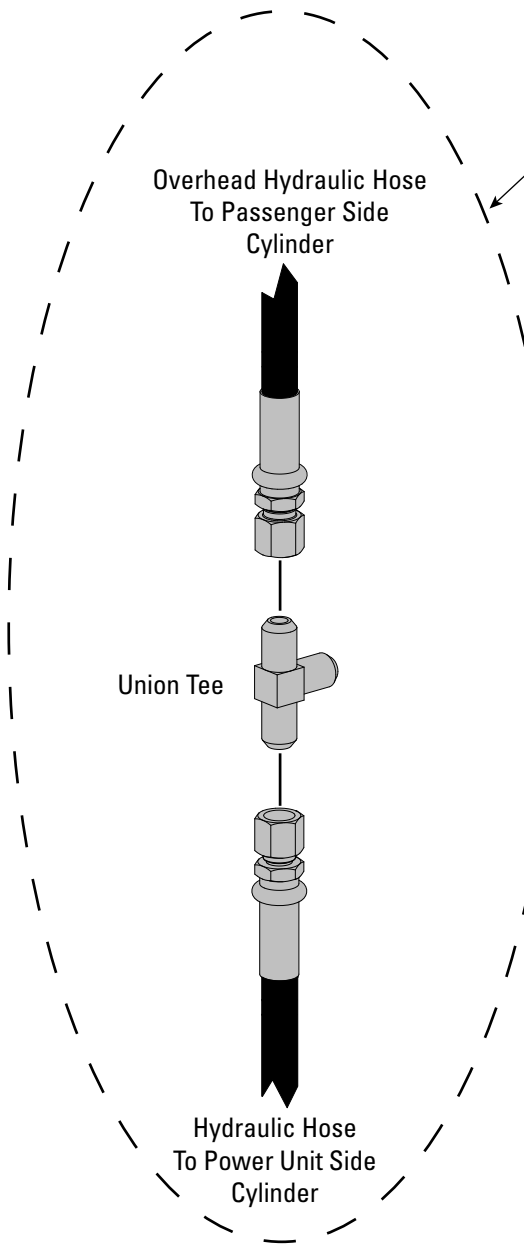

Assemble These 3 Items Before You Route Them Inside The Lift Assembly

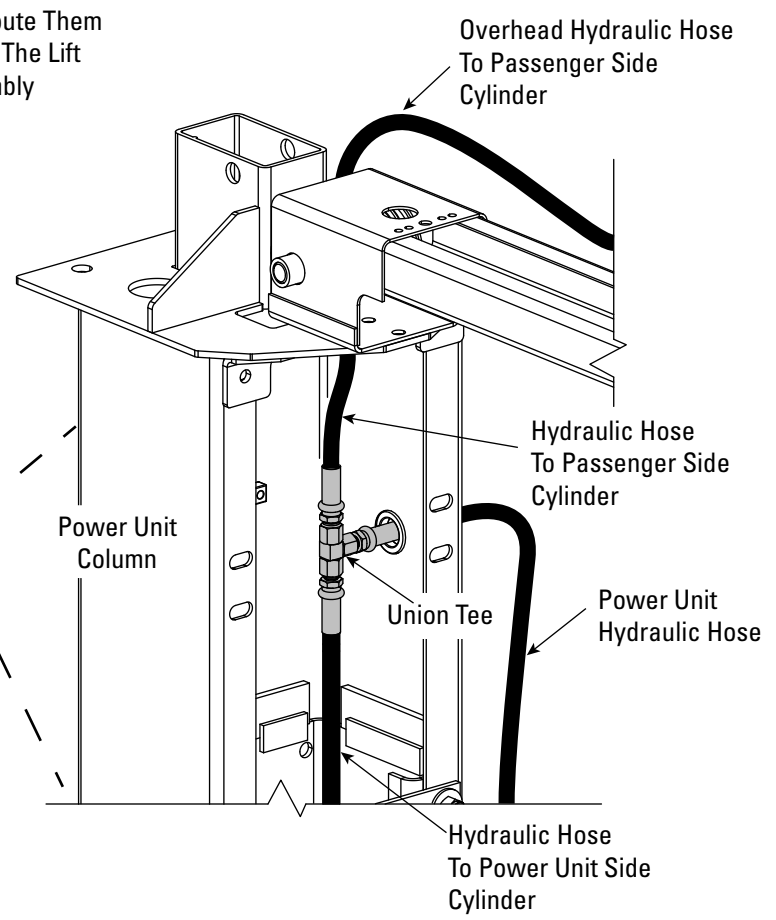
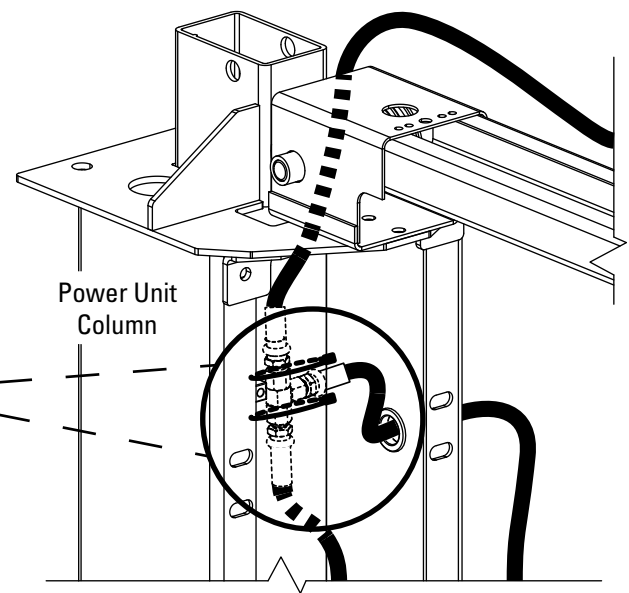

Fig. 12b

IMPORTANT
Wire Tie Union Tee And Hydraulic hoses behind the Cylinder



12. Equalizing Cables

- A) Refer to Fig. 14 for the general cable arrangement.
- B) Run cable from paragraph 4 around overhead sheave and across and down to the opposite carriage, Fig. 14. Install sheave cover, Fig. 13.
- C) Fasten the cable end to the carriage upper tie-off bracket, Fig. 15. Tighten the locknut enough to apply light tension to the cable.
- D) Adjust the tension of both cables during the final adjustments in paragraph 22.

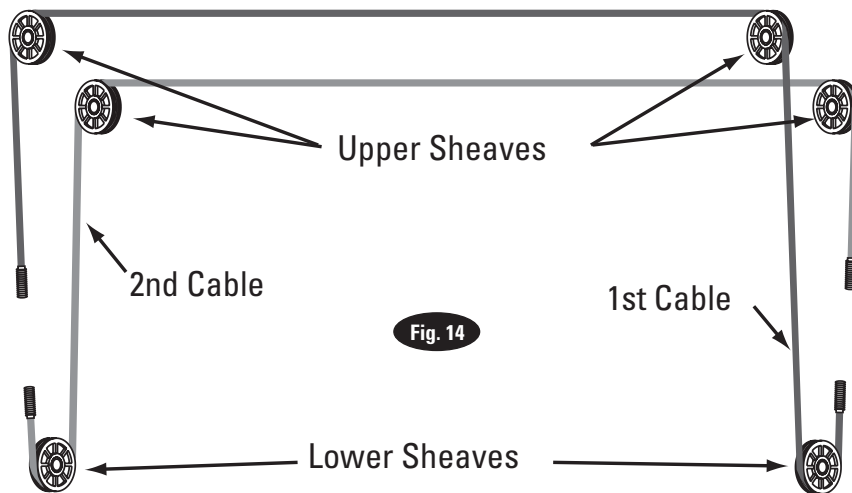
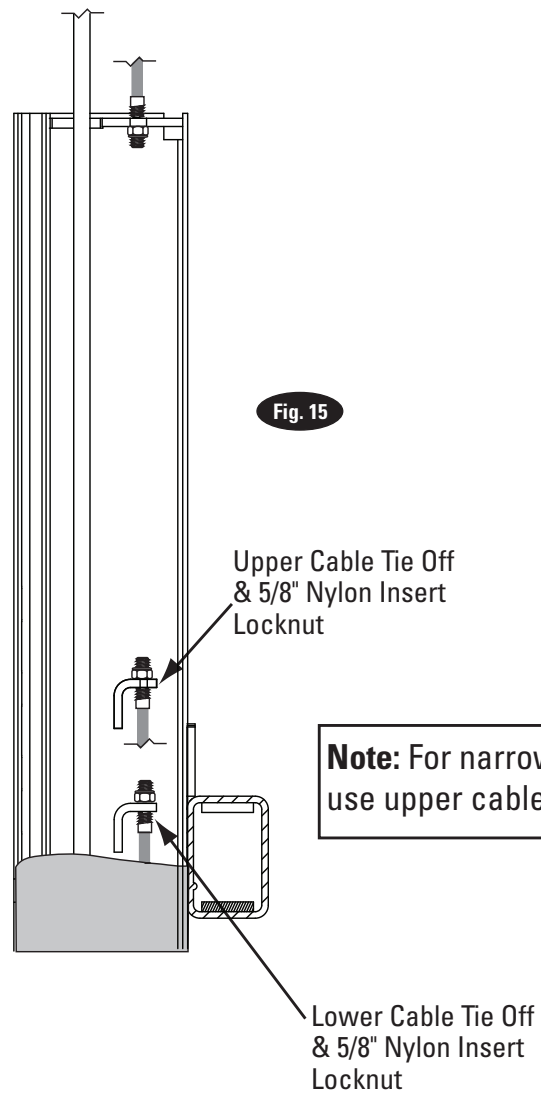
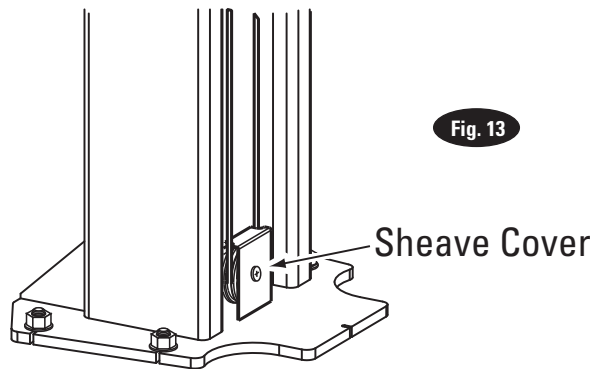

13. Locking Latch Cable

- A) Install latch cable sheave and retaining rings in upper slot of power unit column as shown, Fig. 17.
- B) Slip loop end of cable over end of shoulder screw on right side latch control plate, Fig. 17.
- C) Feed the other end of the cable through the latch cable sheave slot making sure that the cable is running under the bottom side of the latch cable sheave and inside the right column, Fig. 17.
- D) Attach latch cable conduit guide brackets to overhead as shown, Fig. 16a, 16b, & Fig. 16c. Always use the holes on the approach side of the lift. HHCS should be in hole nearest the center of the overhead, Fig. 16b.
- E) Route cable up inside column and through the latch cable guide, Fig. 16a & Fig. 18.

IMPORTANT Using wire ties provided, tie off hydraulic hose snug to cylinders to keep hose away from equalizing cable, Fig. 12a.

- F) Continue routing cable to the left column latch cable guide, Fig. 16a & Fig. 18, routing the cable through the left column latch cable guide, Fig. 16a.
- G) Bring the cable down inside the left column and feed the end of the cable through the lower latch cable sheave slot so that the cable is now back outside the column, Fig. 19.
- H) Route cable under the bottom side of the latch cable sheave, Fig. 19.
- I) At this point you **MUST** install the latch handle, jam nut, and right column latch cover Fig. 17 & Fig. 20. Install latch handle ball, Fig. 20.
- J) Insert cable in cable clamp along one side, loop around shoulder screw and back down, inserting cable along other side of cable clamp, Fig. 19. Place top back on clamp, barely tightening.
- K) Next, pull the control plate down, Fig. 18 & Fig. 19, to eliminate any clearance between the control plate slot and the latch dog pin, Fig. 18.
- L) Using Pliers, pull cable tight and secure the clamp close to the shoulder screw. Tighten clamp.

STANDARD OVERHEAD HEIGHT

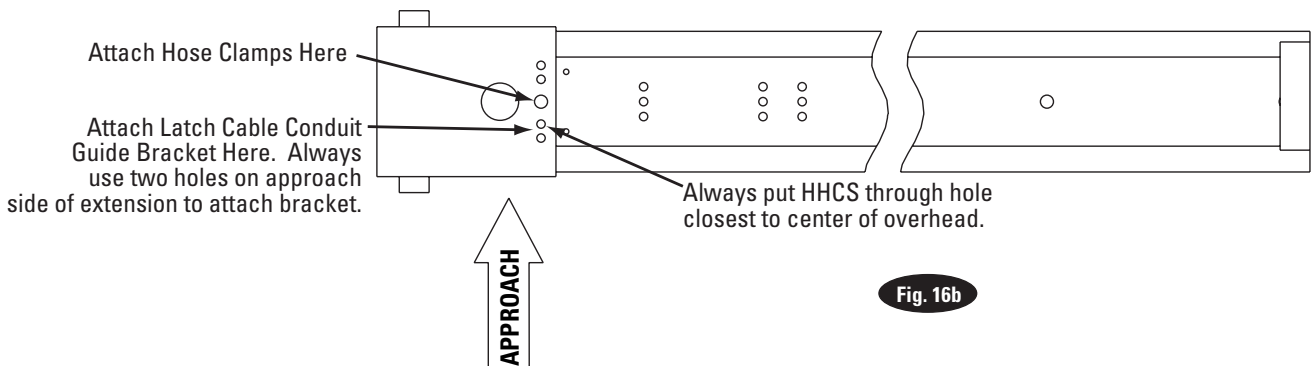
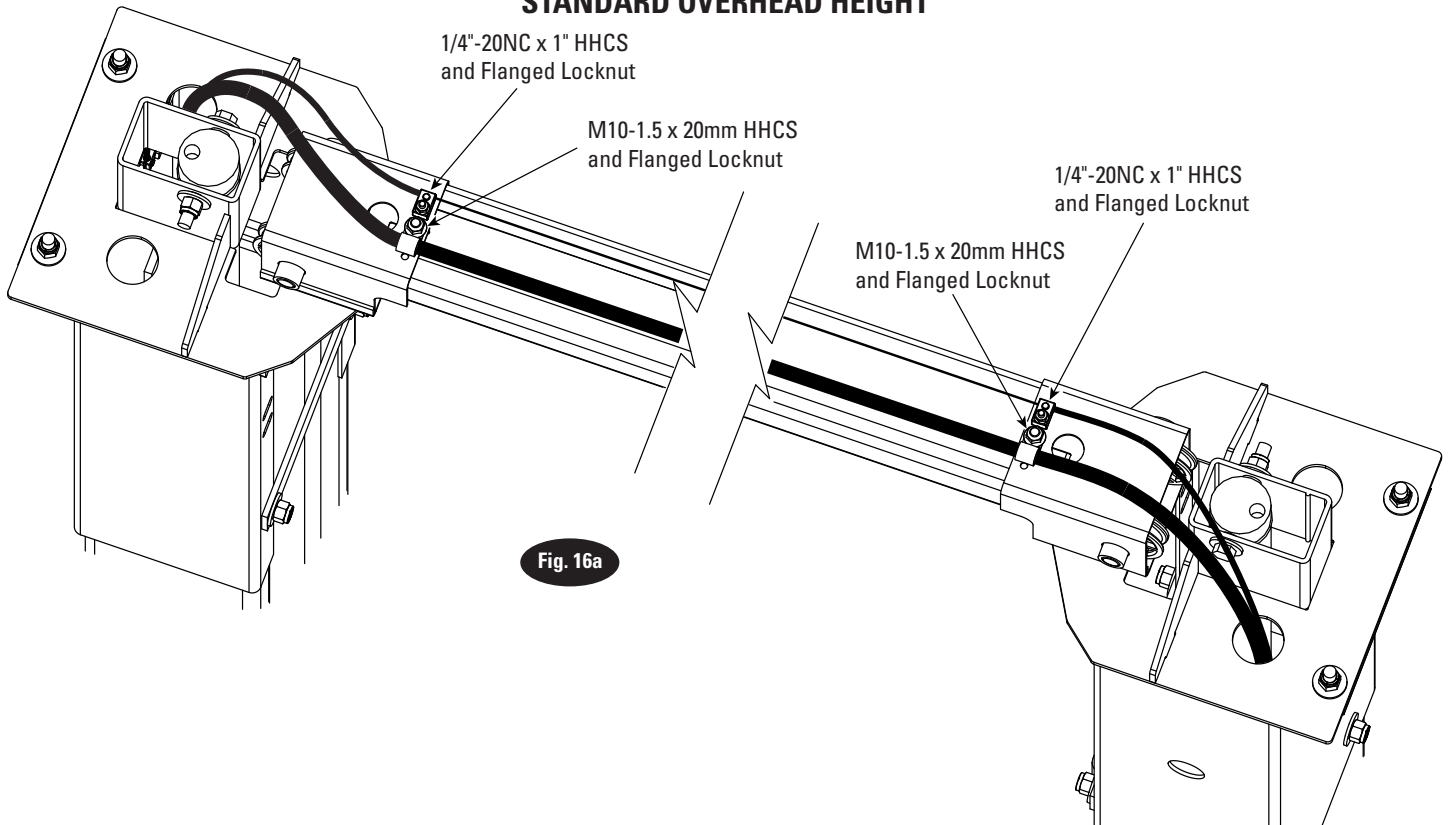

LOW OVERHEAD HEIGHT

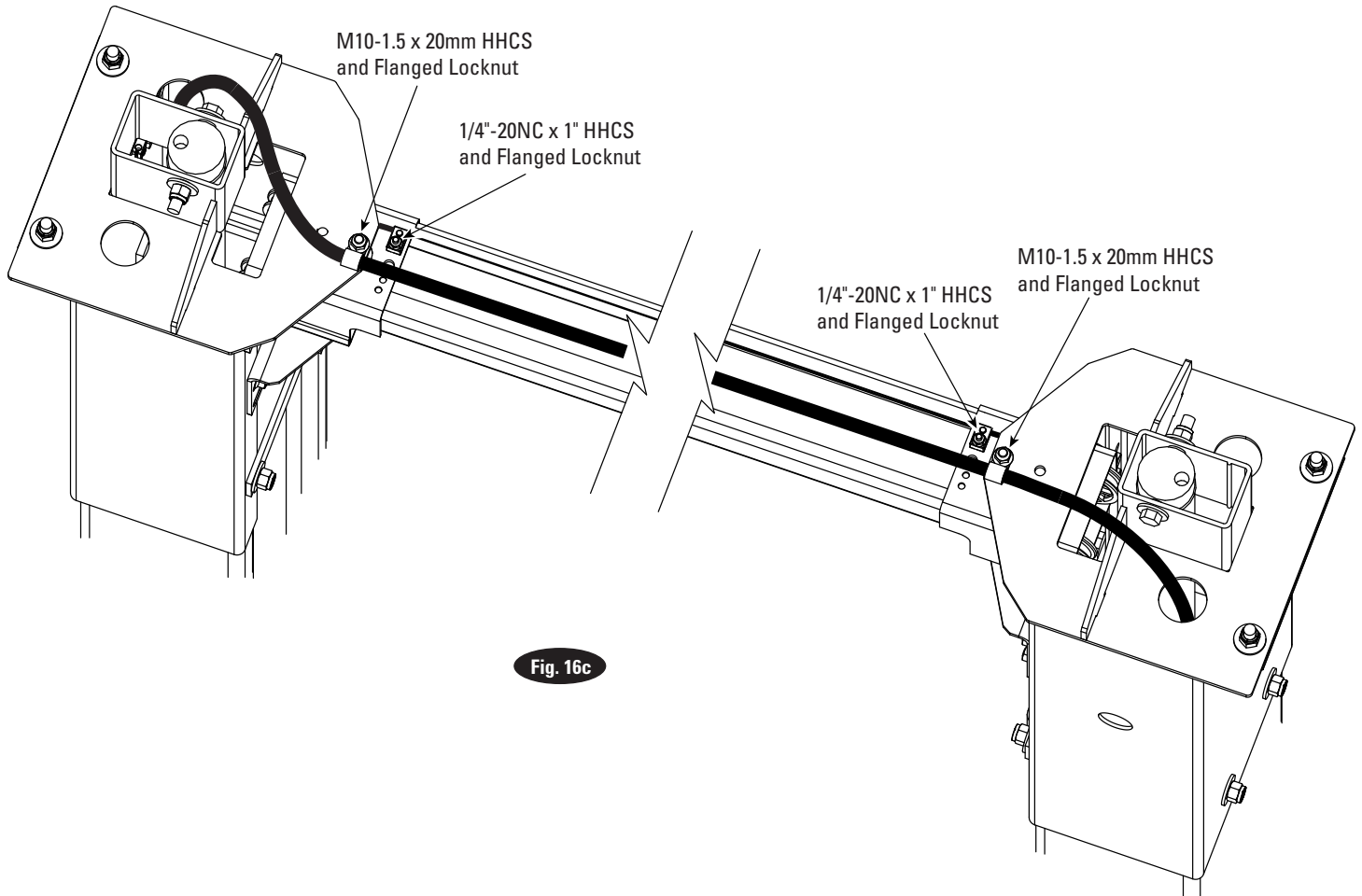

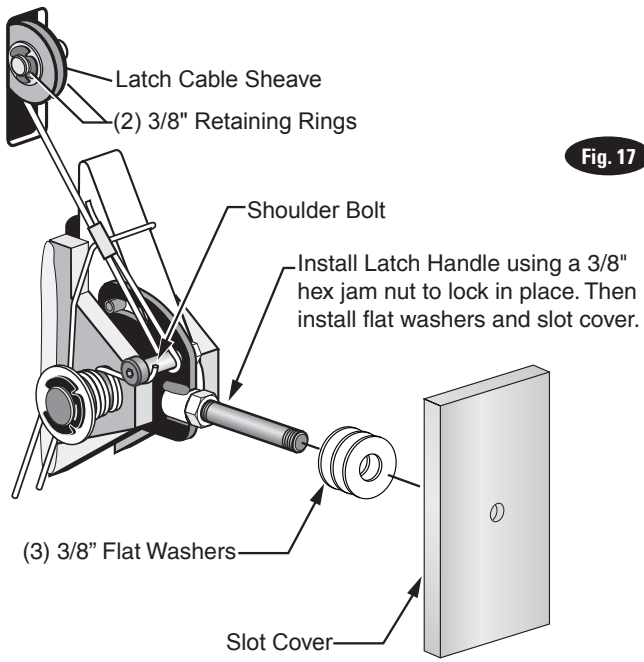

Fig. 17

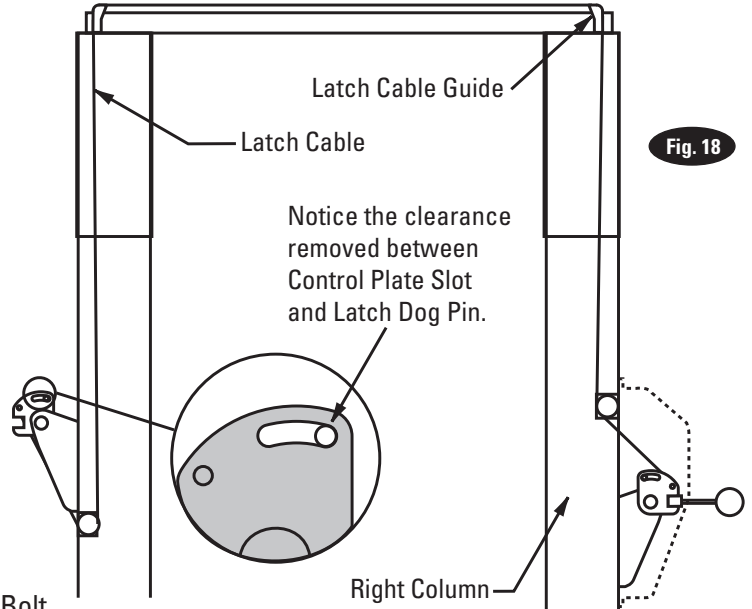

Fig. 18

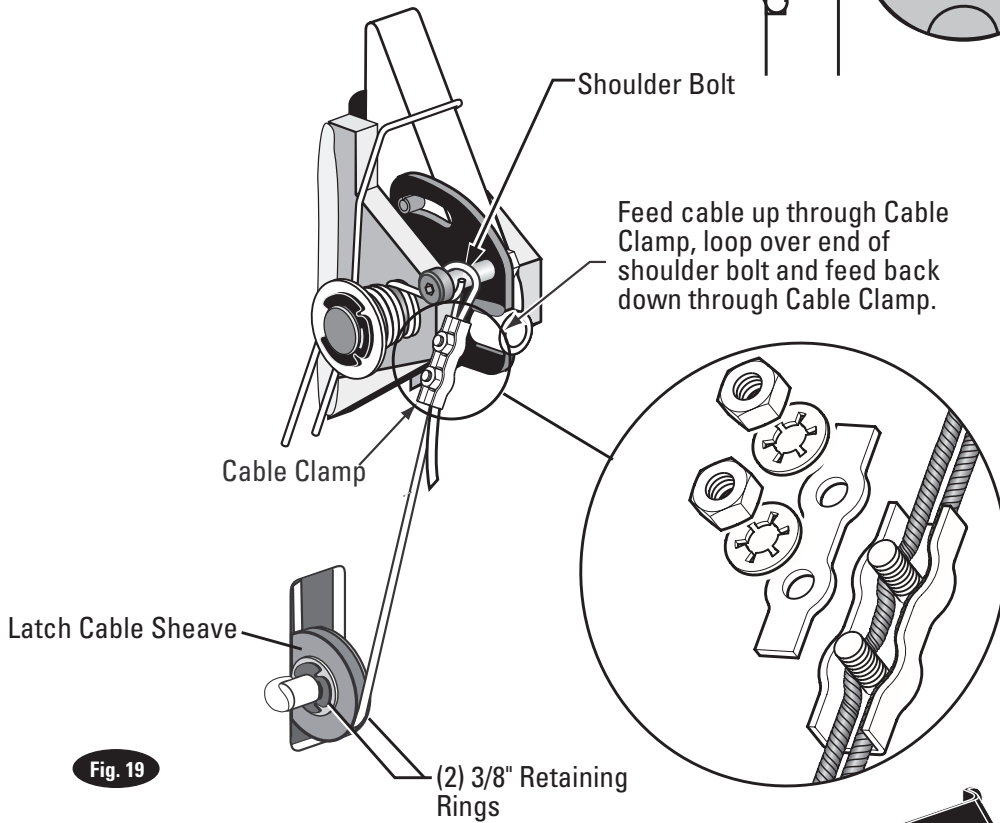

Fig. 19

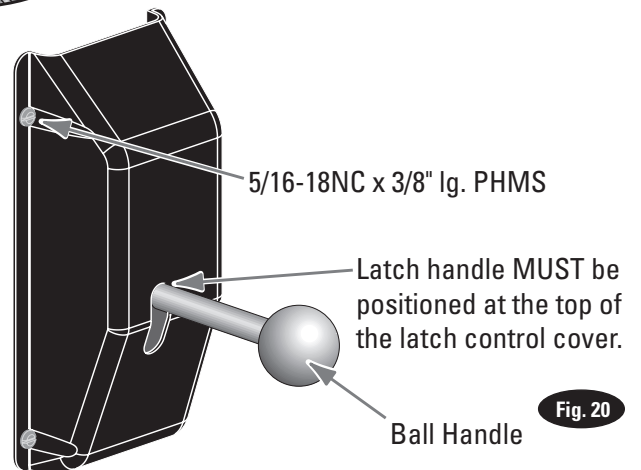

Fig. 20

14. Electrical (1Ø Only): Have a certified electrician run appropriate power supply to motor, Fig. 21 & 22a. Size wire for 20 amp circuit. See Motor Operating Data Table.

CAUTION Never operate the motor on line voltage less than 208V. Motor damage may occur.

IMPORTANT: Use separate circuit for each power unit. Protect each circuit with time delay fuse or circuit breaker. For single phase 208-230V, use 20 amp fuse. Three phase 208-240V, use 20 amp fuse. For three phase 400V and above, use 10 amp fuse. For three phase 380V use 16 amp fuse. For wiring see Fig. 21 & Fig. 23. All wiring must comply with NEC and all local electrical codes.

Single Phase Power Unit

MOTOR OPERATING DATA TABLE - SINGLE PHASE	
LINE VOLTAGE	RUNNING MOTOR VOLTAGE RANGE
208-230V 50Hz.	197-253V
208-230V 60Hz.	197-253V

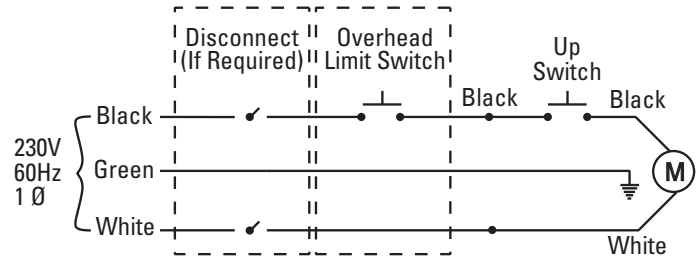

Note: 60Hz. Single phase motor CAN NOT be run on 50Hz. line without a physical change in the motor.

NOTE: Assure cord used for connection between the overhead switch and power unit is of the type specified in:

UL201, Sections 10.1.1.3 & 10.1.1.4

Size for 25 amp circuit. See UL 201, Section 15 for proper wiring requirements for this connection.

Fig. 21

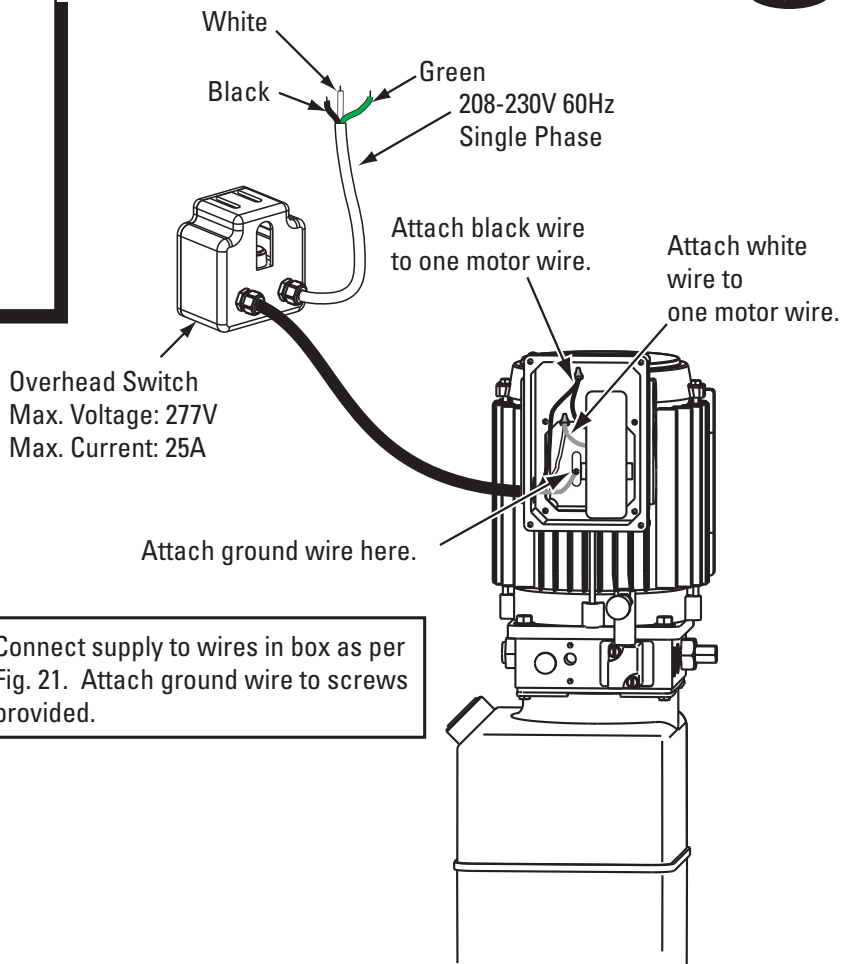

Connect supply to wires in box as per Fig. 21. Attach ground wire to screws provided.

15. 3Ø Control Box Installation:

- Attach Mounting Bracket on column using (4) 5/16" -18NC x 1-1/2" HHCS, (4) 5/16" -18NC Hex Nuts, and (4) 5/16" Ext. Tooth Washers, Fig. 10.
- Attach Control Box to Bracket using (4) 1/4" -20NC x 1/2" HHCS, (4) 1/4" Flat Washers, and (4) 1/4" Star Washers.
- Route cord through strain relief on motor and connect per table on the bottom of page.

Note:

The contactor in the control box has a 480V coil. For installations where the electric supply is 230V, the coil must be replaced with the extra 230V coil shipped with the control box. For 575V electric supply, the coil must be replaced with the extra 575V coil shipped with the lift.

Fig. 22

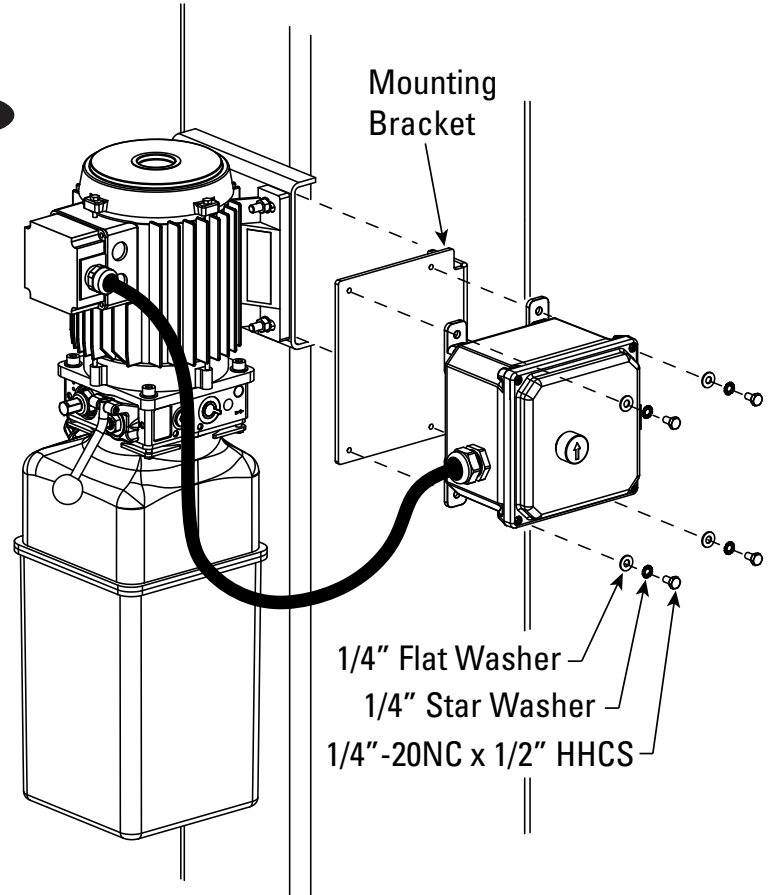
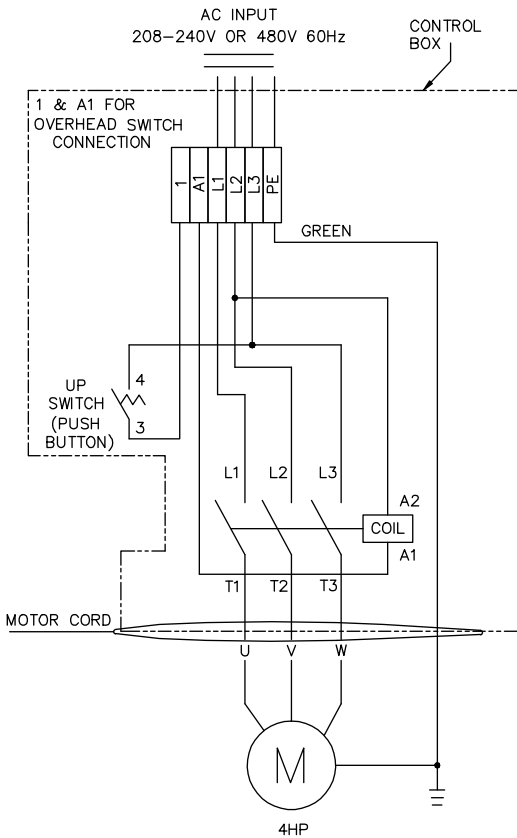
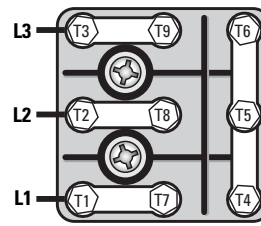

Fig. 23



Use Appropriate Terminal Diagram



208-240V
50-60Hz. 3Ø

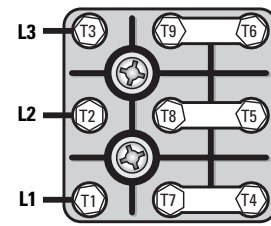

440-480V 50-60Hz. 3Ø
380-400V 50Hz. 3Ø

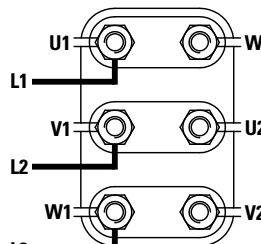

208-240V
50-60Hz. 3Ø

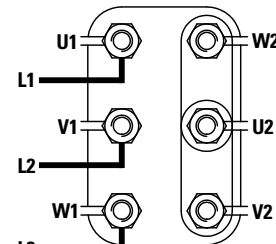

440-480V 50-60Hz. 3Ø
380-400V 50Hz. 3Ø

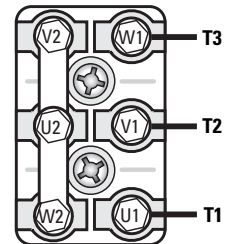

575V 60Hz. 3Ø

Three Phase Power Unit

MOTOR OPERATING DATA TABLE - THREE PHASE	
LINE VOLTAGE	RUNNING MOTOR VOLTAGE RANGE
208-240V 50/60Hz.	197-253V
400V 50Hz.	360-440V
440-480V 50/60Hz.	396V-528V
575V 60Hz.	518V-632V

16. Oil Filling & Bleeding: Use Dexron III ATF, or Hydraulic Fluid that meets ISO 32 specifications. Remove fill-breather cap, Fig. 10. Pour in (8) quarts of fluid. Start unit, raise lift to full rise several times until lift operates smoothly.

CAUTION If fill-breather cap is lost or broken, order replacement. Reservoir must be vented.

17. Overhead switch: Check overhead switch assembly to assure that switch bar is depressing switch plunger sufficiently to actuate the switch. The overhead switch is wired normally open, see Fig. 21. Lift will not operate until weight of switch bar is depressing switch plunger. Verify that Power Unit stops working when switch bar is raised, and re-starts when the bar is released.

18. Arms & Restraints: Before installing arms, raise carriages to a convenient height. Grease swivel arm pins and holes with Lithium grease. Slide arm into yoke, Fig. 24. Install 1-3/4" diameter arm pin(s) and arm stop, Fig. 24.

Install Spring Pin to secure arm pin in place, Fig. 24.

Note: Arm stop will be required on the drive in side of the power unit side. Install at same time as arm pin, Fig. 25. Notice the orientation of arm stop in Fig. 26.

After installing arms and pins, install arm Restraint Gears as follows: Install Restraint Gear onto arm clevis, as shown, Fig. 27. Ensure side of gear marked **TOP** is facing upward, Fig. 27.

NOTE: **TOP** is stamped on top side of gear. You may need to pull up on the pin to allow enough room to install Restraint Gear.

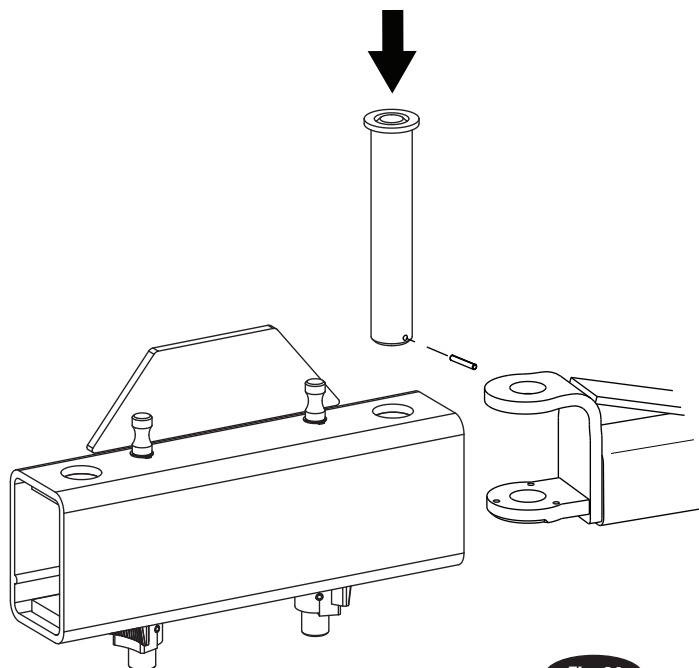
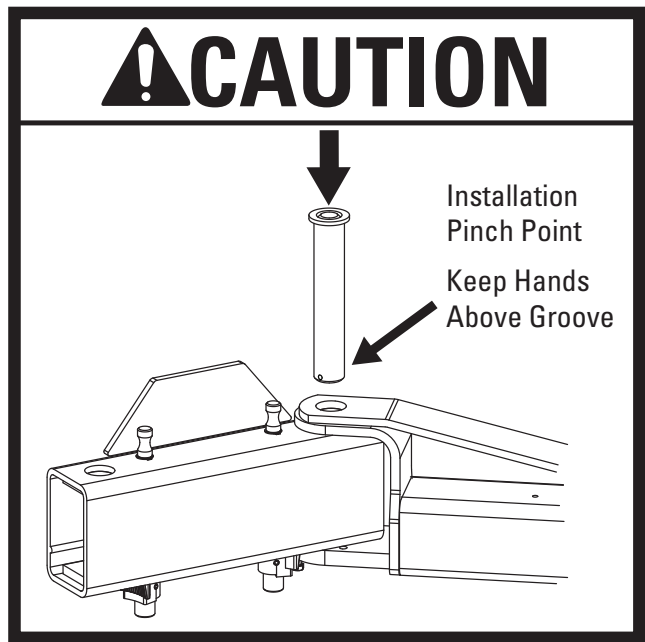

Fig. 24



Arms With 3 Holes In Bearing Bars: Then, install the (2) 3/8" -16NC x 1-1/2" Lg. HHCS ((8) total for all (4) arms) into the gear and arm. Reference Fig. 28 & Fig. 29.

Torque the Restraint Gear bolts to 30-34 ft-lbs. (41-46 Nm)

NOTE: To check operation of arm restraints, raise carriage 1" (25mm) min. from full down position. Pull up on pin and adjust arms to desired position. To engage restraint, let pin-ring down allowing gear teeth to mesh together. It may be necessary to rotate arm slightly to engage gear teeth.

NOTE: Pin, Spring, & Gear Block are all pre-assembled.

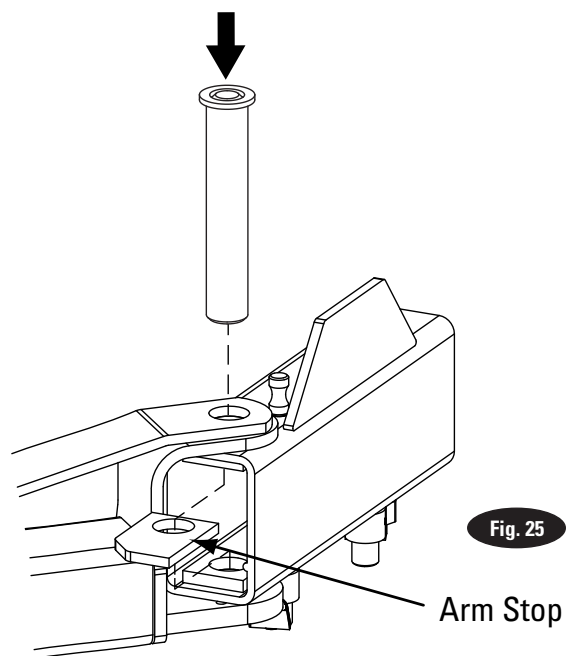
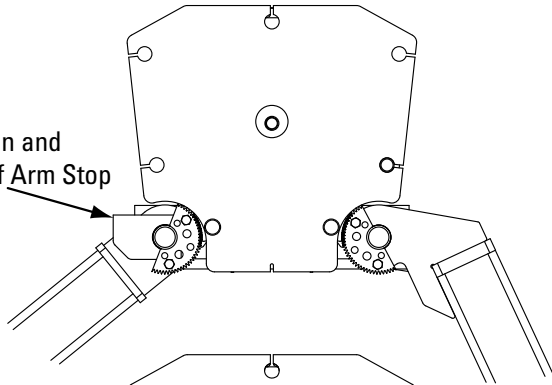

Fig. 25

Note: Location and Orientation of Arm Stop



Note: Location and Orientation of Arm Stop

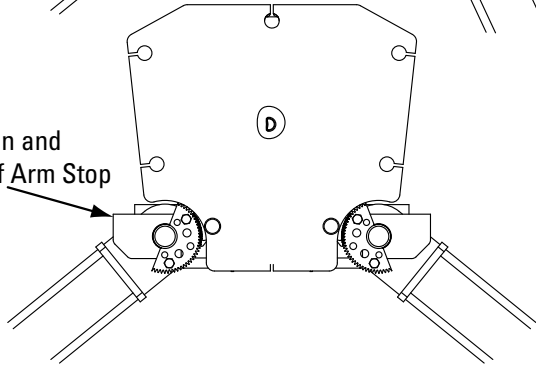

Fig. 26

NOTE: Once arm is installed in yoke, pull up actuator pin and swing arm fully around, being sure that the Restraint Gear and Gear Block always stay aligned. If they do not stay aligned, remove restraint gear and install in the opposite position.

TOP will be marked on top side of restraint gear

NOTE beveled gear orientation

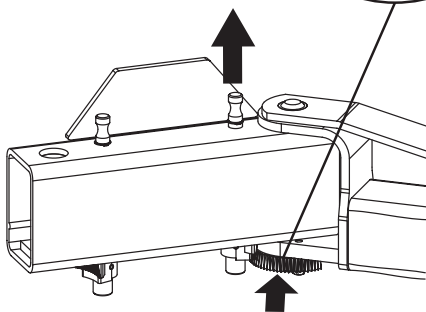
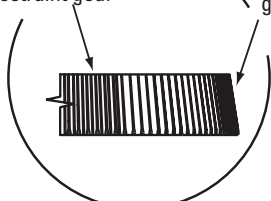

Fig. 27

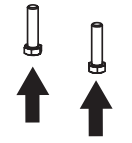
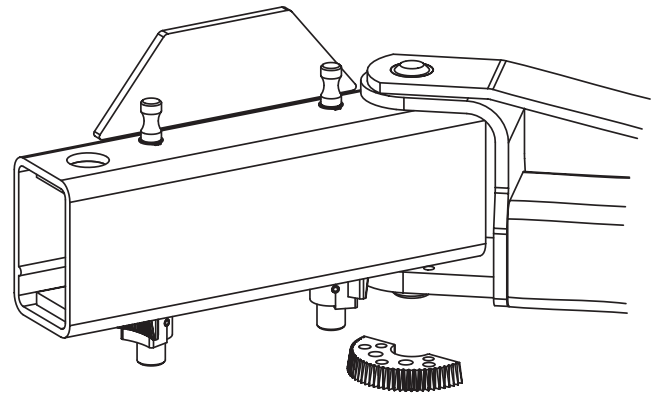
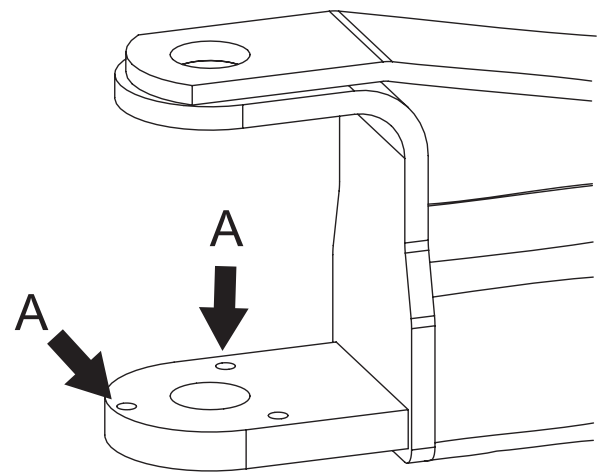
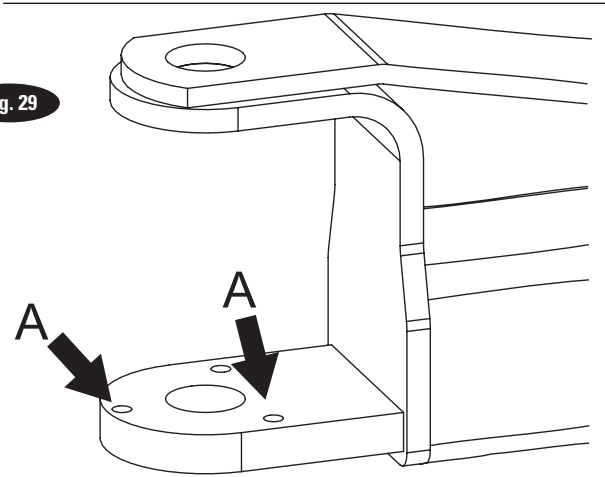

Fig. 28



Use holes marked "A" for Right Front and Left Rear.

Fig. 29



Use holes marked "A" for Left Front and Right Rear.

19. Rubber Bumper Installation (Optional Accessory):

Install rubber bumpers inside of both sides of lift using (2) M8 x 35mm socket bolts, Fig. 30.

Fig. 30

NOTE: Figure shown with optional truck adapters.

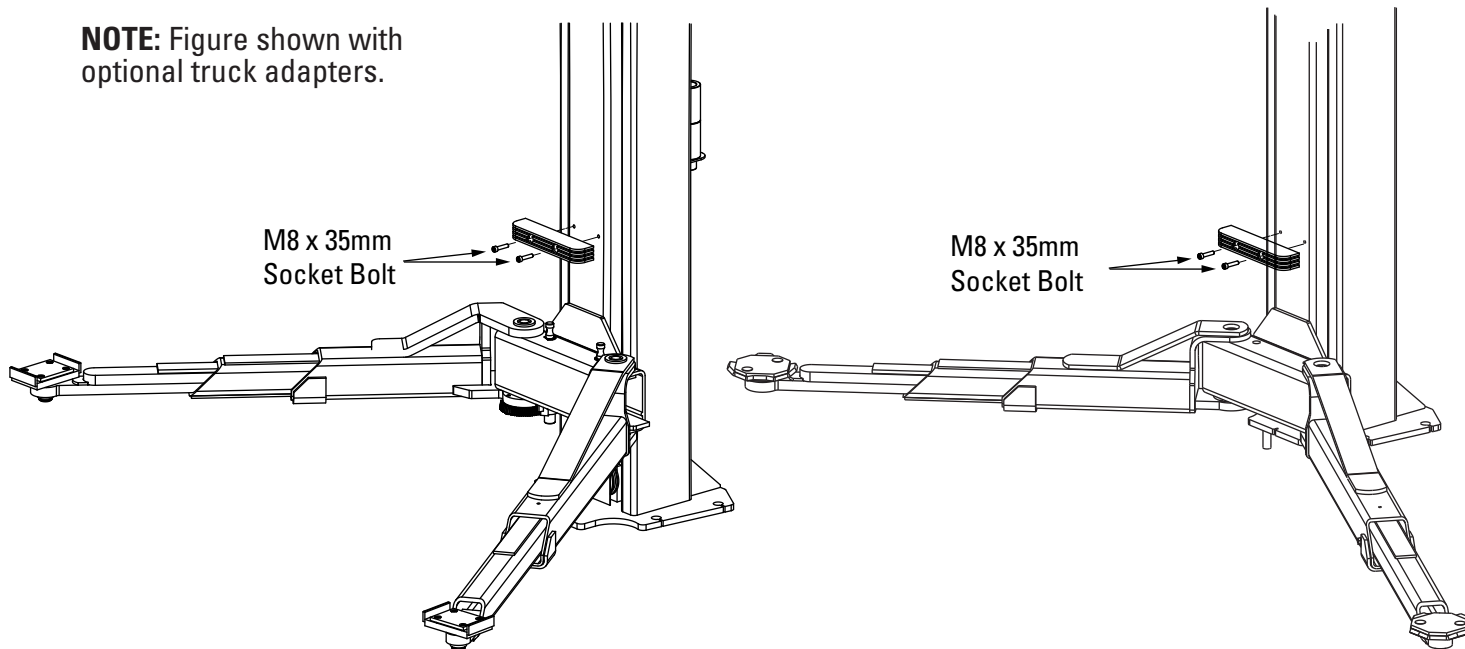

20. Exterior Adapters: Install adapter bracket to outside of each column using (2) 5/16" -18NC x 3/8" PHMS. Then, add adapters to the bracket as shown, Fig. 31.

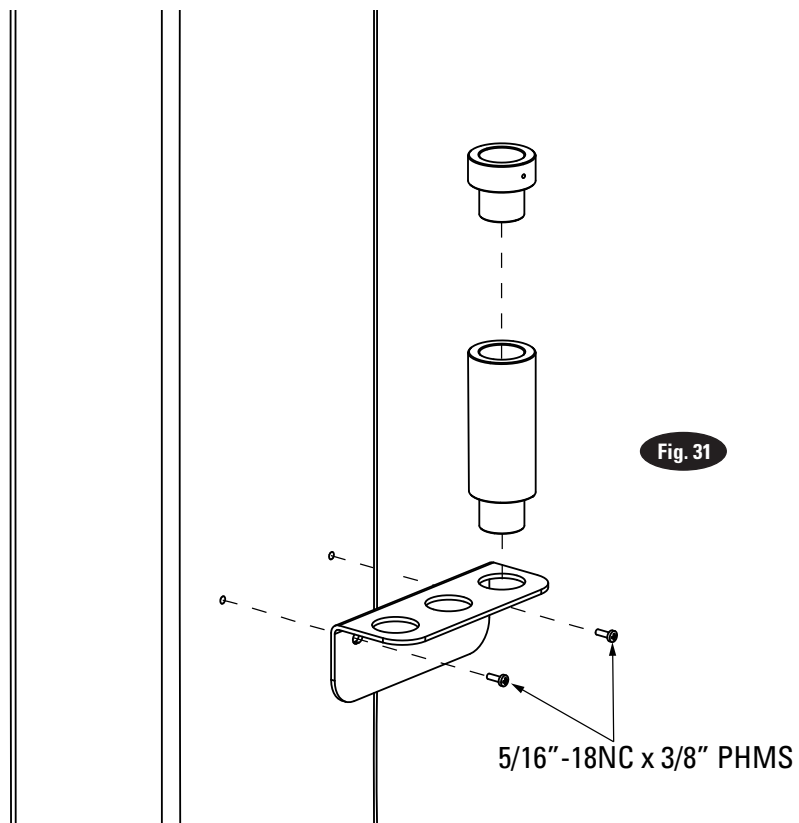

21. Latch Cable Adjustment:

- A) Check to make sure the latch will properly engage and disengage. Slowly release the latch handle. A 1/8" (3mm) gap between the top of the latch dog and the column is allowable, Fig. 32.
- B) When raising, listen to latches to be sure that both latch dogs fall into latch slots. If they do not, loosen clamp and adjust tension as necessary.
- C) Install left latch cover using 5/16-18NC x 3/8" lg PHMS.

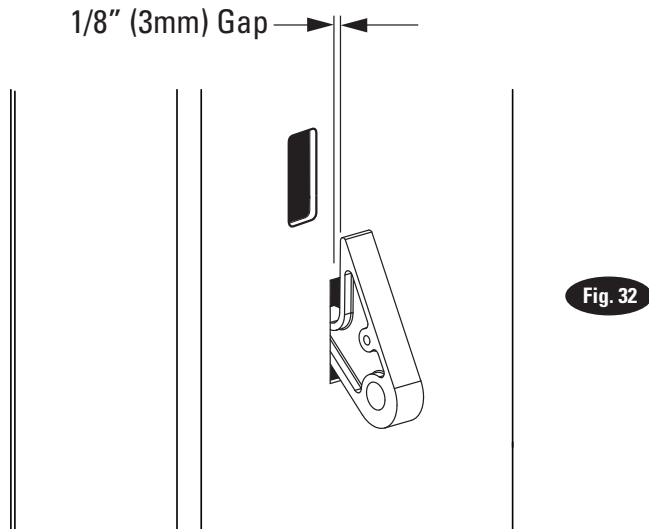

- 24. Latch Release Decal:** Install latch release decal on cover above latch release handle, Fig. 34.

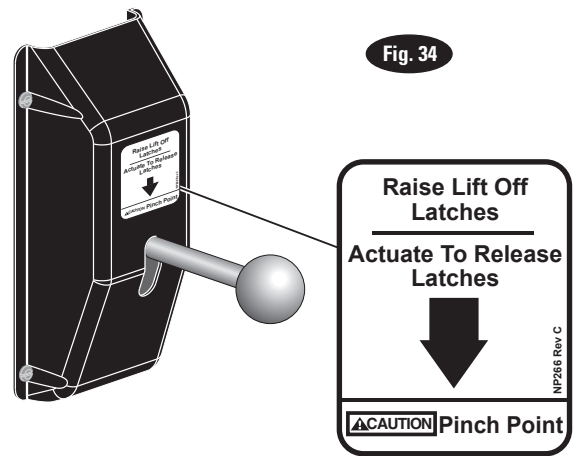

22. Pressure Test: Run lift to full rise and keep motor running for 5 seconds. Stop and check all hose connections. Tighten or reseal if required. Repeat air bleeding of cylinders.

23. Equalizer Cable Adjustment: Raise lift to check equalizer cable tension. Below carriage, grasp adjacent cables between thumb and forefinger, with about 15 lbs. (7 kg) effort you should just pull the cables together, Fig. 33. Adjust at upper tie-offs Fig. 15.

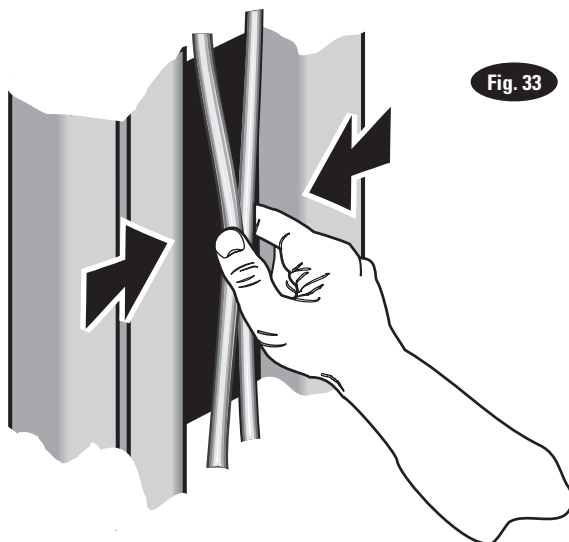

Vehicle Service GroupSM
2700 Lanier Drive
Madison, IN 47250, USA
1-800-640-5438
www.vsgdover.com



© **Vehicle Service GroupSM**
All Rights Reserved. Unless otherwise
indicated, **Vehicle Service GroupSM**
and all other trademarks are property
of Dover Corporation and its affiliates.