

SPO20

SUPER DUTY SYMMETRIC LIFT WITH PATENTED THREE-STAGE TRIO™ ARMS

INCREASE SHOP VERSATILITY!

From Class 1 to Class 5 vehicles, low profile TRIO™ arms maximize lifting capabilities as never before.*



Model shown:
SPO20U0T0BL

20,000 lbs. capacity SHOCKWAVE-equipped lift

PICK UP A GREATER VARIETY OF VEHICLES FASTER AND EASIER ALL ON ONE HEAVY DUTY 2-POST LIFT

Packed with industry leading features, the SPO20 combines high capacity, a low profile stance, wider options and extreme arm reach possibilities with patented lifting speed!

CUSTOMIZE SPO20 LIFTS TO FIT THE NEEDS OF YOUR SHOP!

CHOOSE YOUR:

- Adapter type
- Lift height
- Lift width
- Power option
- Lift accessories

FEATURES:

- 2 adjustable lift height options
- 3 column width options
- Rise height of over 76"
- 20 second lowering time
- Original "Double S" column design
- Performance tested to 20,000 lift cycles
- Nationwide support
- ALI Gold Certified

*NOTE: Level bay floors provide the best underbody clearance needed to accommodate the broadest range of vehicles to spot and lift. Wide setting installations create the best tire clearance on shorter wheelbases. Vehicle axle weight MUST NOT EXCEED one half of total lift capability. Maximum arm load is 1/4 of lift rated capacity.

SPO20 SYMMETRIC 2 POST LIFT

SPO20 TRIO™ ARMS: THREE STAGES OF FLEXIBILITY IN A TWO-PIECE ARM!

No extra heavy inner arms to move for positioning. Greater productivity equals higher profits per bay.

With height and width installation options and low ceiling models, you can be confident we have a lift for all your service jobs.



TRIO 3-STAGE ARM RANGE

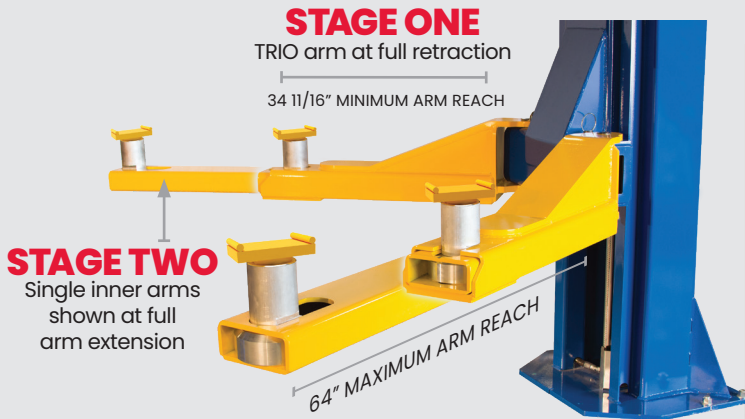

STAGE THREE ADAPTER REACH

Patented multi-position adapter slider

Integrated "third stage" adapter adjustment easily slides to a pinpoint vehicle contact location without having to move heavy inner arms - saving technicians even greater set-up time!

PATENTED STAGE THREE RANGE

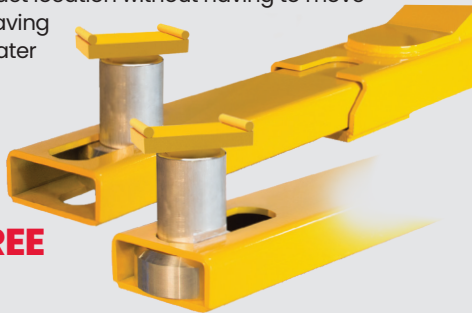

STANDARD WITH CLIP ON ADAPTER PADS

Rubber padded adapter clips provide lifting option for spotting unibody passenger cars. Set of four (4) standard.

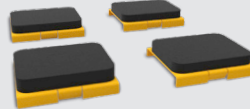

SPO TRIO™ ARMS 22% GREATER ARM REACH VERSUS CONVENTIONAL 2-STAGE ARMS

A SPO20 TRIO ARMS ARM REACH RANGE: 64" to 34-11/16"
ADAPTER AREA COVERAGE: 9,088 SQUARE INCHES

B 2-STAGE ARMS CONVENTIONAL ARM REACH RANGE: 62" to 38-1/2"
ADAPTER AREA COVERAGE: 7,395 SQUARE INCHES

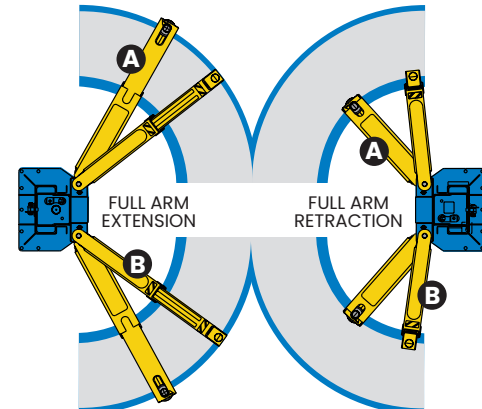

GREATER REACH AND RETRACTION
MEASURED IN WIDEST STANCE INSTALLATION

THREAD-UP ADAPTERS FOR EASY VEHICLE CONTACT

Adjustable adapters with rubber pads come standard with ultra-strong 10" (2 each) and 5" (4 each) stackable adapter extensions.



10" High Step Height: 15 31/32" to 18 1/32"



OPTIONAL ROUND ADAPTERS FOR UNIBODY VEHICLES

Round rubber adapters provide a 3/8" lower profile for pinch weld lifting.

LIFTING CAPACITY:
11,000 lbs. per arm

SPO20 FEATURES

THREE COLUMN WIDTH OPTIONS

From 12' 11" to 13' 11"

Improve vehicle access for your shop.

MULTIPLE HEIGHT ADJUSTMENT OPTIONS

Standard height options from 15' to 16' 6"

MAXIMIZE WORKING RISE HEIGHT

From 77 - 31/32" to 80 - 1/32"

Rise is measured from floor to adapter in the lowest and highest position.

AIR OPERATED LOCK RELEASE

Single point air operated lock release.

SINGLE-PIECE OVERHEAD

Robust design for greater strength.

OPTIONAL SHOCKWAVE™ EQUIPPED DC POWER

Supercharge your lift with SHOCKWAVE™ and make your lifting speed twice as fast!

Patented DC power system reduces operating costs.°°

- Accelerate productivity immediately!
- Increase service orders per bay!
- Added productivity equals EXTRA PROFIT!

SPOTLINE™ MOTION ACTIVATED LASER

Standard with SHOCKWAVE-equipped lifts, this laser-guided system helps center vehicles quickly and accurately the first time.



WHEEL SPOTTING DISHES

Two (2) three-position spotting dishes come standard.



36 SECOND RISE TIME!°



Model shown: **SPO20U0T0BL**

20,000 lbs. capacity SHOCKWAVE-equipped lift

° Actual rise times may vary depending on weight of the vehicle.

°° Shockwave's patented DC power system uses two standard Group 24 batteries with built in 110v power battery charger. Batteries not included.

ROTARY[®]

BY ROTARY SOLUTIONS

SPO20 LIFTS[†]

BL = Blue / RD = Red

STANDARD POWER	SPO20N0T0BL SPO20N0TLRD
SHOCKWAVE EQUIPPED	SPO20U0T0BL SPO20U0TLRD
Lifting Capacity	20,000 lbs.
Rise*	77" – 80"
Overall Height	15' to 16' 6"
Overall Width	NARROW: 12' 11" STANDARD: 13' 5" WIDE: 13' 11"
Drive-thru	NARROW: 105 11/32" STANDARD: 111 11/32" WIDE: 117 11/32"
Inside Columns	NARROW: 120 15/32" STANDARD: 126 15/32" WIDE: 132 15/32"
Arm Reach Front & Rear Min/Max Reach	34 11/16" – 64"
Minimum Adapter Height FLOOR TO TOP OF ADAPTER EAR	5 31/32"
Maximum Adapter Height	18 1/32"
Minimum Bay Size	15' x 30'
Ceiling Height Minimum	15' 2" to 16' 8"
Low Ceiling (LC) Model	13' 8" to 14' 8"
Motor / Voltage With SHOCKWAVE	4 HP, 208–230V 5 HP / 110V
Time of Rise / Descent With SHOCKWAVE**	81 / 20 seconds 60 / 20 seconds

*Rise measures lowest and highest position of the supplied adapters from floor to full cylinder stroke

**Optional DC SHOCKWAVE battery power cycle times vary depending on vehicle weight



Service your entire fleet on a single lift!

With a 20,000 lbs. capacity and optional low ceiling models, you can be assured we have a lift for all your service jobs.

OPTIONAL ACCESSORIES

LIGHT KITS

TECH LIGHT™ Line Light 2

2 ultra slim light wands attach to columns for effective lighting. 4 magnetic clips provide easy positioning on columns.

Includes:

- (2) 96 LED lights with 25' of cable and 20W power supply
- 3' spiral cords - stretches to 16" for placement under vehicle
- Magnetic junction box
- Input voltage 100-240 V AC
- Each measures 34"

#FA5701



TECH LIGHT™ Line Light R

Rechargeable LED inspection hand lamp with top spot light. Supplied with flexible suspension clips holder with both hook and magnet for positioning the light where you need it.

- 180 lumen in main light operates up to 3 hours
- 120 lumen in spot light operates up to 6 hours
- 4 hour charging time

Additional suspension solutions available as accessories.

#FA5702



TIRE AND WHEEL LIFTS

- Air-operated with adjustable lifting and lowering speeds
- Easy alignment of wheel and hub
- Includes air hose and auxiliary air tool connection

#MW-200
200 lbs. capacity



#MW-500
500 lbs. capacity



†NOTE: Level bay floors provide the best underbody clearance needed to accommodate the broadest range of vehicles to spot and lift. Wide setting installations create the best tire clearance on shorter wheelbases.

Vehicle axle weight MUST NOT EXCEED one half of total lift capacity.

Maximum arm load is 1/4 of lift rated capacity.



ROTARY SOLUTIONS

To learn more about all of our automotive service and repair solutions or to contact your local distributor, visit us at www.RotarySolutions.com today.

Need assistance or have questions? We're here to help:
800.445.5438 / Sales: insidesales@rotarysolutions.com
Technical Support: HD-techsupport@rotarysolutions.com

ROTARY SOLUTIONS™

2700 Lanier Drive | Madison, IN 47250, U.S.A.

Lit# Rotary.SPO20.Cutsheet.03.01.2026

©2026 VEHICLE SERVICE GROUP™

All Rights Reserved. Unless otherwise indicated, ROTARY SOLUTIONS™, VEHICLE SERVICE GROUP™, DOVER® and all other trademarks are property of Dover Corporation and its affiliates.

Product specifications, part numbers, images and component descriptions are subject to change without notice or liability.