

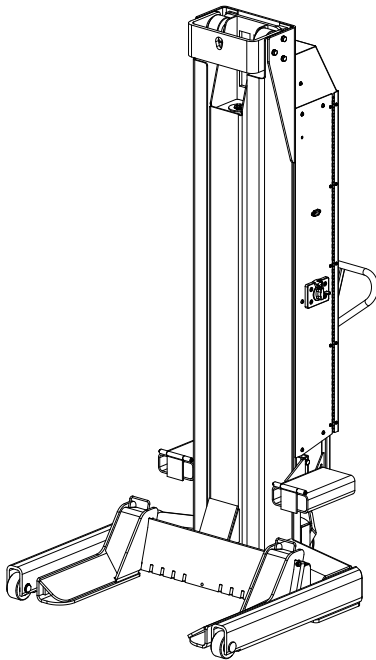

MCHA14 / MCHF14 / MCHM14 Series  
MCHA19 / MCHF19 / MCHM19 Series  
MCHA20R / MCHF20R / MCHM20R Series  
Column Lift Systems  
24V DC Powered

MCHA14 / MCHF14 / MCHM14 14,000 PER COLUMN  
MCHA19 / MCHF19 / MCHM19 18,800 PER COLUMN  
MCHA20R / MCHF20R / MCHM20R 20,000 PER COLUMN



MCHF14 / MCHM14

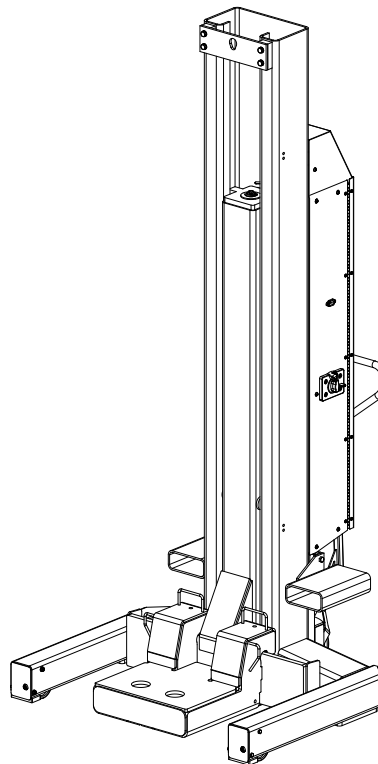

MCHA20R / MCHF20R / MCHM20R

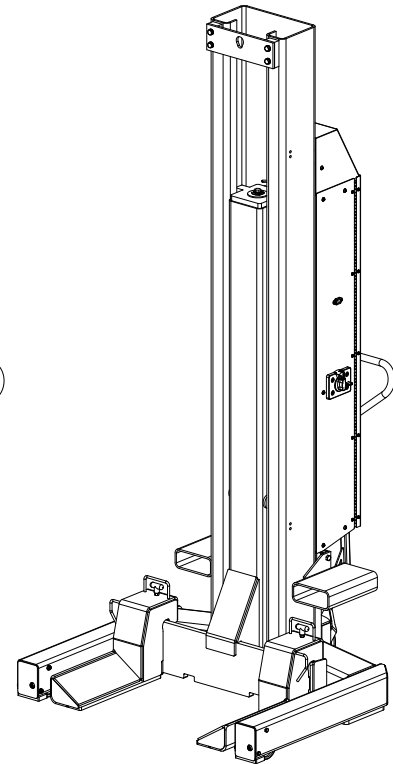

MCHA14 / MCHA19 / MCHF19 / MCHM19

**▲ IMPORTANT** Reference ANSI/ALI ALIS,  
Safety Requirements for  
Installation and Service of Automotive Lifts  
before installing lift.

## INDEX

|  |    |                                |    |
|--|----|--------------------------------|----|
| Owner/Employer Responsibilities .....  | 2  | Emergency Stop .....           | 18 |
| Lift Lockout/Tagout Procedure .....    | 3  | Bleeding.....                  | 20 |
| Safety Instructions .....              | 4  | Battery Charging .....         | 21 |
| Set-Up Instructions .....              | 6  | Maintenance Instructions ..... | 22 |
| Lift Initialization Instructions ..... | 10 | Trouble Shooting .....         | 24 |
| Lift Operation .....                   | 13 | Wiring Diagram .....           | 26 |
| Detailed Operating Instructions .....  | 14 | Safety Information .....       | 27 |

---

### The Owner/Employer:

- Shall ensure that lift operators are qualified and that they are trained in the safe use and operation of the lift using the manufacturer's operating instructions; ALI/SM 93-1, ALI Lifting it Right safety manual; ALI/ST-90 ALI Safety Tips card; ANSI/ALI ALOIM-2008, American National Standard for Automotive Lifts-Safety Requirements for Operation, Inspection and Maintenance; ALI/WL Series, ALI Uniform Warning Label Decals/Placards; and in the case of frame engaging lifts, ALI/LP-GUIDE, Vehicle Lifting Points/Quick Reference Guide for Frame Engaging Lifts.
- Shall establish procedures to periodically inspect the lift in accordance with the lift manufacturer's instructions or ANSI/ALI ALOIM-2008, American National Standard for Automotive Lifts-Safety Requirements for Operation, Inspection and Maintenance; and The Employer Shall ensure that lift inspectors are qualified and that they are adequately trained in the inspection of the lift.
- Shall establish procedures to periodically maintain the lift in accordance with the lift manufacturer's instructions or ANSI/ALI ALOIM-2008, American National Standard for Automotive Lifts-Safety Requirements for Operation, Inspection and Maintenance; and The Employer Shall ensure that lift maintenance personnel are qualified and that they are adequately trained in the maintenance of the lift.
- Shall maintain the periodic inspection and maintenance records recommended by the manufacturer or ANSI/ALI ALOIM-2008, American National Standard for Automotive Lifts-Safety Requirements for Operation, Inspection and Maintenance.
- Shall display the lift manufacturer's operating instructions; ALI/SM 93-1, ALI Lifting it Right safety manual; ALI/ST-90 ALI Safety Tips card; ANSI/ALI ALOIM-2008, American National Standard for Automotive Lifts-Safety Requirements for Operation, Inspection and Maintenance; and in the case of frame engaging lifts, ALI/LP-GUIDE, Vehicle Lifting Points/Quick Reference Guide for Frame Engaging Lifts; in a conspicuous location in the lift area convenient to the operator.
- Shall provide necessary lockout/tagout means for energy sources per ANSI Z244.1-1982 (R1993), Safety Requirements for the Lockout/Tagout of Energy Sources, before beginning any lift repairs.
- Shall not modify the lift in any manner without the prior written consent of the manufacturer.

# LIFT LOCKOUT/TAGOUT PROCEDURE

## Purpose

This procedure establishes the minimum requirements for the lockout of energy that could cause injury to personnel by the operation of lifts in need of repair or being serviced. All employees shall comply with this procedure.

## Responsibility

The responsibility for assuring that this procedure is followed is binding upon all employees and service personnel from outside service companies (i.e., Authorized Rotary Installers, contactors, etc.). All employees shall be instructed in the safety significance of the lockout procedure by the facility owner/manager. Each new or transferred employee along with visiting outside service personnel shall be instructed by the owner/manager (or assigned designee) in the purpose and use of the lockout procedure.

## Preparation

Employees authorized to perform lockout shall ensure that the appropriate energy isolating device (i.e., circuit breaker, fuse, disconnect, etc.) is identified for the lift being locked out. Other such devices for other equipment may be located in close proximity of the appropriate energy isolating device. If the identity of the device is in question, see the shop supervisor for resolution. Assure that proper authorization is received prior to performing the lockout procedure.

## Sequence of Lockout Procedure

- 1) Notify all affected employees that a lockout is being performed and the reason for it.
- 2) Unload the subject lift. Shut it down and assure the disconnect switch is "OFF" if one is provided on the lift.
- 3) The authorized lockout person operates the main energy isolation device removing power to the subject lift.
  - If this is a lockable device, the authorized lockout person places the assigned padlock on the device to prevent its unintentional reactivation. An appropriate tag is applied stating the person's name, at least 3" x 6" in size, an easily noticeable color, and states not to operate device or remove tag.
  - If this device is a non-lockable circuit breaker or fuse, replace with a "dummy" device and tag it appropriately as mentioned above.
- 4) Attempt to operate lift to assure the lockout is working. Be sure to return any switches to the "OFF" position.
- 5) The equipment is now locked out and ready for the required maintenance or service.

## Restoring Equipment to Service

- 1) Assure the work on the lift is complete and the area is clear of tools, vehicles, and personnel.
- 2) At this point, the authorized person can remove the lock (or dummy circuit breaker or fuse) & tag and activate the energy isolating device so that the lift may again be placed into operation.

## Rules for Using Lockout Procedure

Use the Lockout Procedure whenever the lift is being repaired or serviced, waiting for repair when current operation could cause possible injury to personnel, or for any other situation when unintentional operation could injure personnel. No attempt shall be made to operate the lift when the energy isolating device is locked out.

# SAFETY INSTRUCTIONS

- Inspect your lift daily. Never operate if it malfunctions or if it has broken or damaged parts. Use only qualified lift service personnel and genuine Rotary parts to make repairs.
- Thoroughly train all employees in use and care of lift, using manufacturer's instructions and "Lifting It Right" and "Safety Instructions" supplied with the lift.
- Never allow unauthorized or untrained persons to position vehicle/lift or operate lift.
- Prohibit unauthorized persons from being in shop area while lift is in use.
- Do Not permit anyone on lift or inside vehicle when it is either being raised or lowered.
- Do Not operate lift while batteries are charging.
- Always keep area around lift free of tools, debris, grease and oil.
- Never Overload lift. Capacity of lift is shown on nameplate affixed to the lift.
- Do Not hit or run over lift forks or base. This could damage lift or vehicle. Before driving vehicle into area, position lift units to provide unobstructed entrance onto lift area.
- Load vehicle on lift carefully. Position lift forks to fully contact the vehicle tires. Release parking brake on vehicle. Raise lift until tires clear the floor. Check lift forks for secure contact with vehicle tires. Raise lift to desired working height.
- Do Not block open or override self-closing lift controls, they are designed to return to the Off or Neutral position when released.
- Remain clear of lift and vehicle when lowering.
- Avoid excessive rocking of vehicle while on lift.
- Clear area if vehicle is in danger of falling.
- Remove tool trays, stands, etc. before lowering lift.
- Position lift units to provide an unobstructed exit before removing vehicle from lift area.

- Do Not perform any maintenance on the control panels until the power has been shut off to the lift.
- Do Not operate equipment with a damaged cord or if the equipment has been dropped or damaged.
- Lift operates at a sound level of approx. 80db(A).
- Do Not drive over pendant.
- Never use remote controller below floor grade.
- Always lower columns onto the locking latches.
- Confirm all lift channels match before operating lift.
- For proper operation, the lift must be operated in multiples of 2. Never operate with an odd number of columns.
- Do not use or place remote near magnetic source.



**⚠️ WARNING** **DO NOT** use on asphalt. Lift must be on concrete with a minimum strength of 3000PSI and a minimum thickness of 4.5". Maximum allowed floor slope is 1/8" per foot side to side of vehicle and 1/4" per foot front to rear of vehicle. **DO NOT** use on a suspended floor structure without specific approval from structural engineer.

Ensure vehicle tires are properly inflated before lifting.  
**DO NOT** exceed tire load rating when raising vehicle.

**DO NOT** raise/lower only one side of a vehicle.

Lift only on same axle. **DO NOT** stagger between axles.

**⚠️ WARNING** Permit only trained personnel to operate lift. After reviewing these instructions, become familiar with the lift controls by running the lift through a few cycles before loading a vehicle on lift. Observe and heed **SAFETY** and **WARNING** labels on the lift.

**⚠️ WARNING** This motor has internal arcing or sparking parts. To minimize the Risk of Explosion, **DO NOT** expose to flammable vapors.

**OPERATING CONDITIONS:** Lift is not intended for outdoor use or storage and has an operating ambient temperature range of 41°-104°F (5°-40°C). This product is intended for indoor use only in a dry location.

**DO NOT** use lift in a manner other than intended. Included (but not limited to) examples of unapproved uses of the lift are: lifting vehicle by only one side, lifting different axles with a column pair (lifting on the diagonal), and lifting non-approved items.

# SET-UP INSTRUCTIONS

1. Unpack lift in desired operating area. Remove and discard protective wrapping, as well as unpainted shipping bracket, Fig. 1. One column in set will have remote and charger in a box mounted on column, Fig. 2.

2. Adjusting Wheels: Remove bolt securing wheel assembly in place, Fig. 3. Adjust M20 Bolt (30mm or 1-3/16" wrench) to provide clearance to floor at back of column (recommended approx. 3/8" clearance), Fig. 3. Adjust M10 (8mm or 5/16" Allen wrench) socket head bolts at front of legs, until head is flush with surface. The lift will collapse springs and set on ground when loaded, Fig. 4.

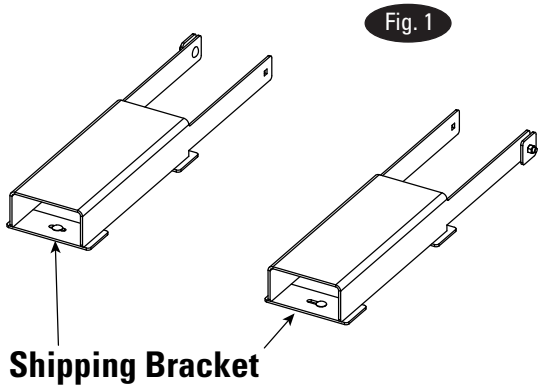

Adjust To Provide Floor Clearance (Approx. 3/8")  
Tighten Raises, Loosening Lowers Column Ride Height (30mm or 1-3/16" Wrench)

Remove Bolt Securing Wheel Assembly

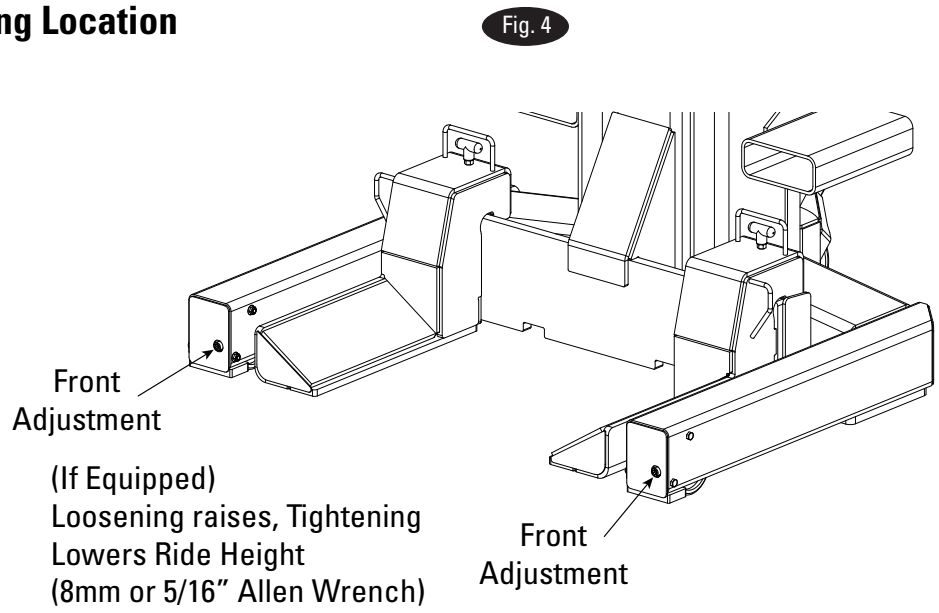
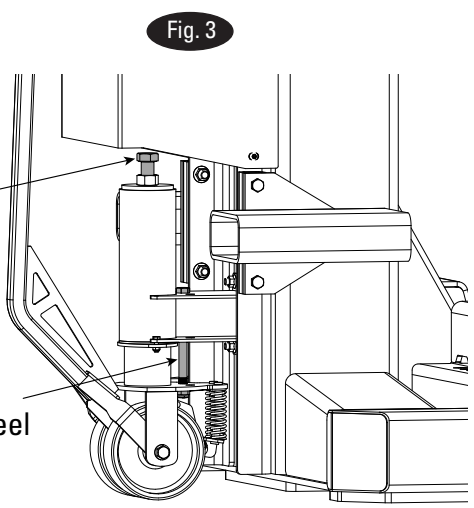

**ATTENTION:** Standard order columns are shipped with oil and batteries ready to use. If ordered without these please do the following steps. Otherwise skip to #5. If breather cap is attached to E-stop of disconnect, plug will need to be swapped (Open Cabinet/remove plug/install breather cap/close cabinet).

- Open power unit cover by removing the 3x M8 BHCS (Button Head Cap Screw). Fill power unit tank with ISOVG32 hydraulic oil, Fig. 5. Tank capacity is approximately 10 - 12 quarts depending on model. Fill until fluid is to full mark on side of the tank. Short filling may cause vapor lock to occur. Filling to line when column raised will result in oil coming out of cap when lowered. **NOTE** See Bleeding Column Cylinder pg. 20.
- Mount two batteries in location shown, Fig. 5. Deep cycle marine batteries are standard and should be used, unless shop plans to keep column plugged in while in operation, in those shops AGM (Advanced Glass Mat) Batteries are recommended.

**Recommended Battery Specifications:**

- 12V DC Sealed Deep Cycle Battery (\*AGM if will be stay plugged in).
- Group Size 24, 27 or 31.
- Min. 105 AH Capacity (At 20 AH Rate).
- Stud Threaded Terminals.

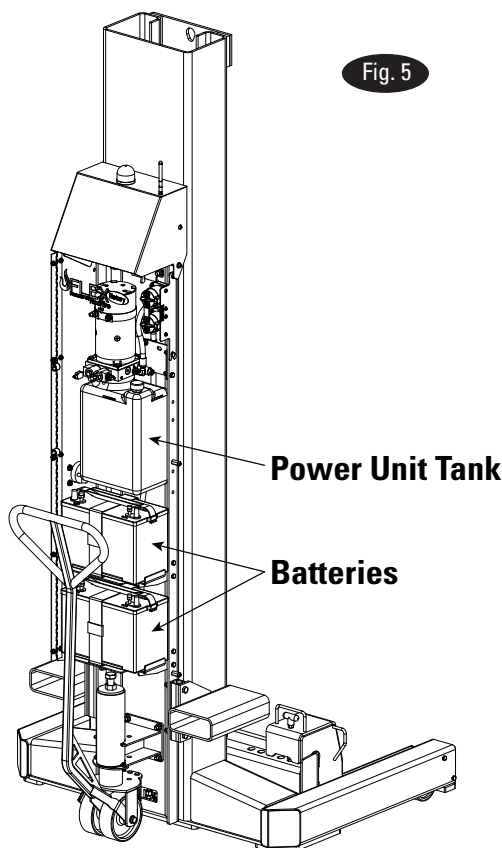

Fig. 5

Battery wires are clearly marked/labeled inside the unit itself. Electrical schematic is on the inside of the door for reference. Be careful not to short batteries to column when wiring.

Install tie-down straps on batteries as shown.

Close lift and re-install M8 BHCS removed earlier.

- Charge Column:** Column are shipped with partial charge due to shipping codes. They should be fully charged before full usage, though a few unloaded lifts may be able to be completed prior to charging. Plug column into 100-240V AC 50/60 HZ wall socket. Column charger light (in window on column) will glow red when charging and green when charged. Light may be difficult to see pending viewing angle. If plugged in and light on charger not turning open cabinet and check that charger is on. Charger should not stay plugged in unless AGM batteries where used.
- Charge Remote:** Remotes are shipped with partial charge due to shipping codes. Determine best location for remote charger. Remote is used for each lift so consider dock placement accordingly. Charger dock can be placed on workstation or mounted on a wall using mounting key holes on back, Fig. 6. Plug charge into dock feeding wire into wire manager on bottom of dock and charger to wall socket (100-240V AC 50/60 HZ). Place remote into charger dock. Charger wall plug has indicator light which will glow red or blink green when charging and glow solid green when charged.
- Device Tracker compartment:** A small compartment is located under the battery for mounting a device tracker (Tile or similar) if the owner is concerned about lost/stolen remote. Best practice is store remote on charging dock when not in use.

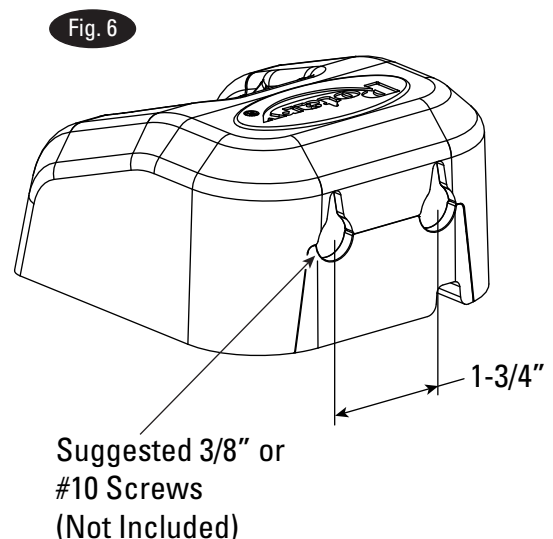

8. Antenna Mounting: Mount / position antenna on the top of the column. If screw on antenna, antenna will be zip-tied in baggie on disconnect. Mount to bulkhead on the right side of the hood (removing cover from bulkhead), Fig. 7. If magnetically mounted antenna shipped pre-mounted on the hood but against the column. Reposition to corner of hood for optimal performance, Fig. 8.

9. Remove wire-tie from disconnect, Fig. 9. Lift is ready to use. Lift Initialization Instructions section go through lift operation. Recommend 1 lift cycle without vehicle on lift to get familiar with the lift.

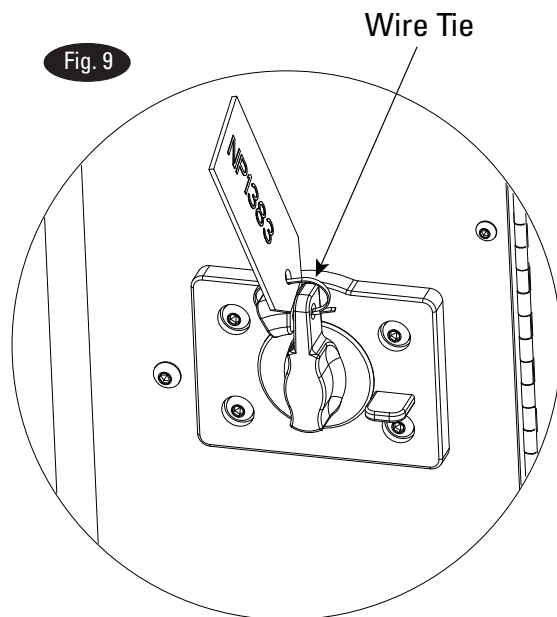
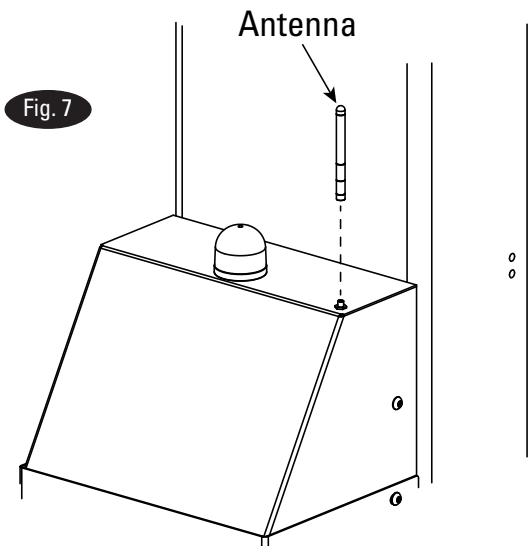

10. Complete Warranty Tag for full warranty coverage.

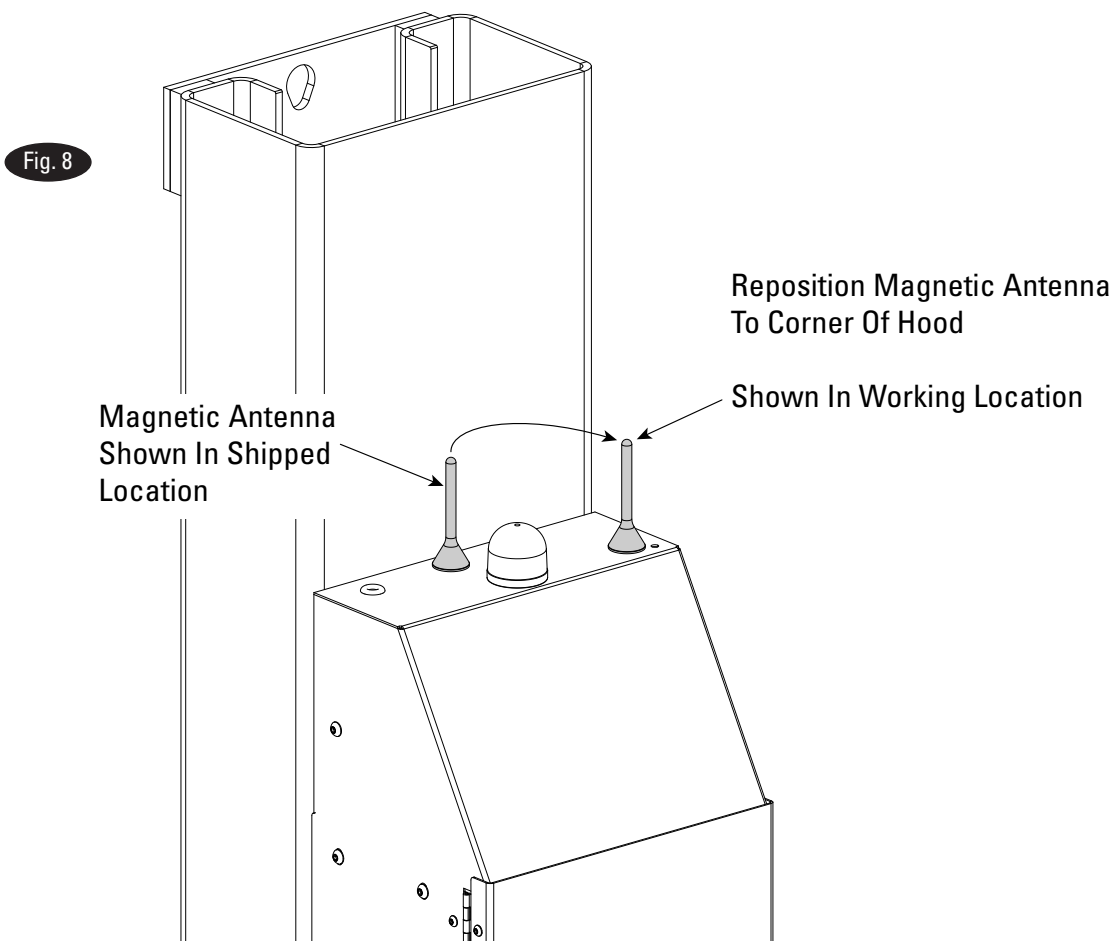

## Quick Start Up Guide

### Initial Set Up:

Power Up The Remote Controller

Select System ID

Select Number of Columns

Position Columns

Power Up Each Column

System will Auto lock and run as a group

Emergency Stop Button

Will Disable Remote Control Communications

And Shut The Entire System Down

Rotate Button To Restart The System Again

Remote Control Power Button

Optional Accessory Column Lights On/Off

Digital Display:

System ID: All Columns Must Be On The

Same System ID As The Remote

Controller

**53** System ID Example

Column Count: Lets You Set Up  
Number Of Columns

**64** Column Count Example  
8 Column Max

**P** "P" Press Protect™ Prevents Accidental  
Activation Of The Remote Controller  
Press & Release Any Button To Re-Wake System

See Operation Instructions Decal For List Of  
Error Codes

5) Selection And Enter Buttons  
Used During Setup

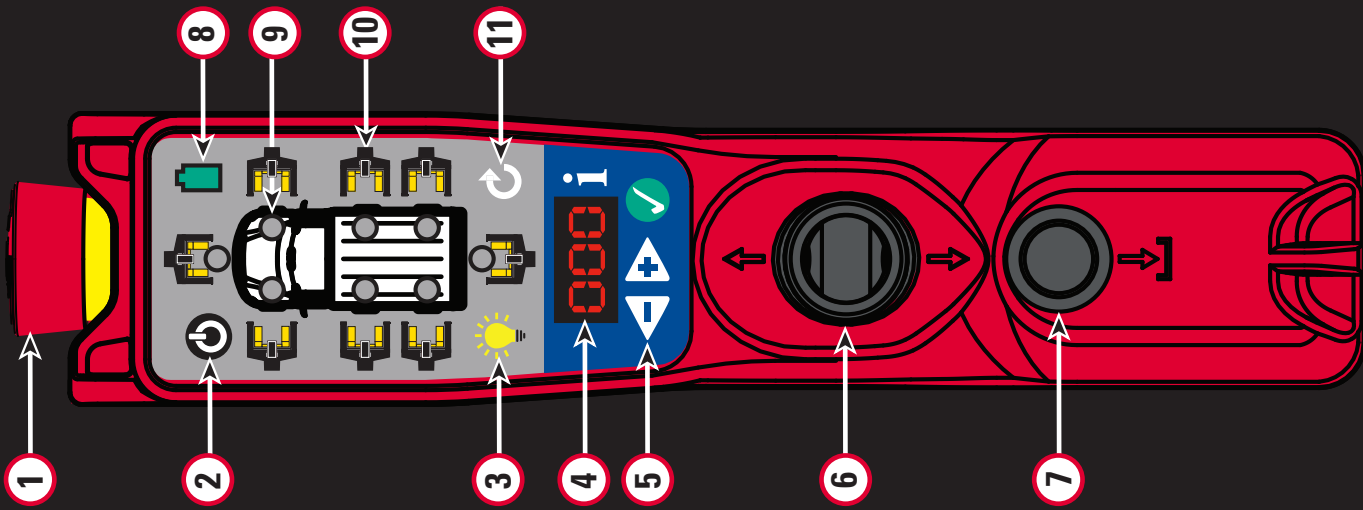

6) Joystick:  
Up - Raise  
Partial Down - Slow Lower  
Full Down - Normal Lower

7) Lower To Lock:  
Lowers Columns Onto The Locks  
Green Light On Top Of Columns  
Will Illuminate When Engaged

8) Remote Controller Power Indicator

9) Column Indicator Light:  
Yellow Flashing - Next Column  
Position To Add To System

● Yellow - Not Active Column

● Green - Active Column

● Red - Column with Error or  
Height Limit Reached

10) Column Buttons - Activate/Deactivate  
Pair of Columns

11) Lock/Unlock The Group Or  
Refresh/Wake Up The Group



For Setup Video And Other Information:  
<http://www.rotarylift.com/machflex/>

## LIFT INITIALIZATION INSTRUCTIONS:







1. The service area must be clear of all personnel before the vehicle is positioned.

**⚠ WARNING** Locate lift on level concrete surface with a minimum strength of 3000 psi.

2. Spotting: Position the vehicle in the location where it is to be lifted.

**Note:** See Fig. 12 and Fig. 13 for the general arrangement of each lift column.





3. Start Remote Controller:

Press Power button  on Remote Controller for 2 seconds. Remote Controller will prompt for system ID  (flashing last used System ID, example S 3). Change if needed using the menu arrows  , then select using enter key . Remote Controller will prompt for quantity of columns in system  (flashing last used quantity, example C 4).

**Note:** See Fig. 10 for Remote Controller membrane menu display example. See Fig. 11 for Control panel display example.

4. Column Placement and Configuration: Remote Controller directs operator to first column placement position (default to Front Right). Position one column per Wheel Engaging and Column Movement. Ensure fork width is adjusted to properly accommodate the tire/wheel size. Turn on the

Power Up Switch .

5. Column will boot and display will prompt for System ID  (flashing last used System ID). Change if needed using the menu arrows  , then select using enter key . Column assumes current channel is no response to menu prompting within 9 seconds.

Column will beep and indicator beacon will flash  indicating successful link to Remote Controller master controller.

**Note:** First column configured will beep and flash 1 time, second column configured will beep and flash 2 times.

## Remote Controller Panel Diagram

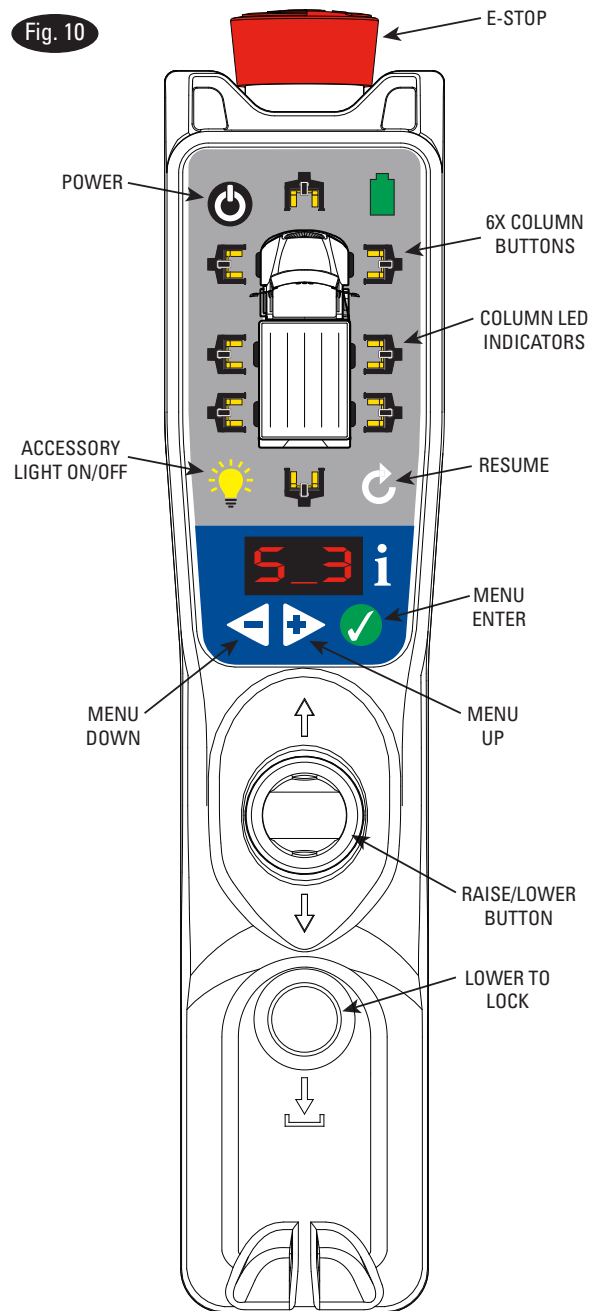

6. Remote Controller will now direct operator what column to position next. Position using loading instructions from step 4.

7. Repeats steps 4-6 until columns quantity selected in step 3 have been configured. System will automatically lock when all columns are configured. After last column is configured all columns will beep and indicator light will be turned on to signify ready to lift.

# CONTROL PANEL DIAGRAM

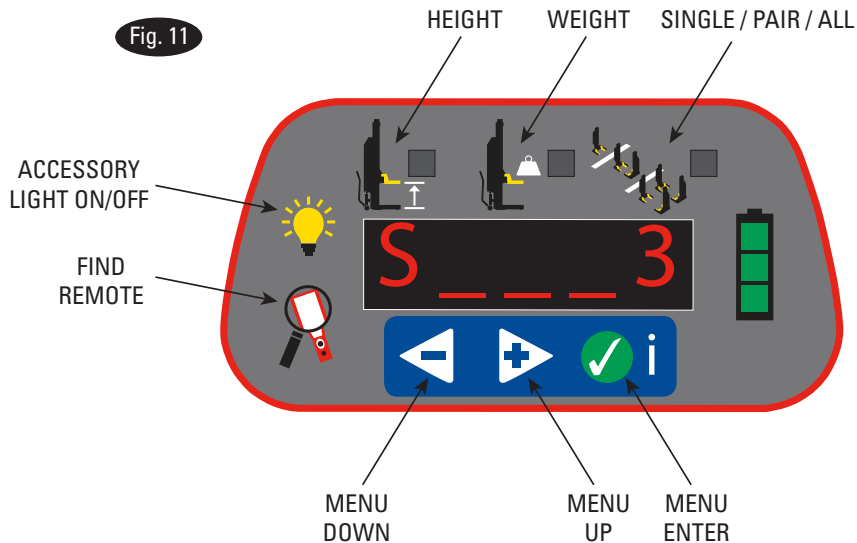

## 1. Column Display - Buttons Information:



Enter button - Accept current prompt or acknowledge error code



Menu Up and Down Button - scrolling buttons

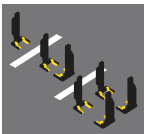

Mode Button - Changes grouping mode of columns. Single/Pair/All



Light Button - Turn on accessory lights (if equipped)



Find Remote Button - If remote actively linked remote will flash and beep. Will not work on unlocked set or if remote is powered off.



If Height Indicator Green - Displayed value is raised height (Default Inches)



If Weight Indicator Green - Displayed value is approximate weight on hydraulics of the column (default in 100's of pounds). Accuracy improved by raising then tapping lower momentarily.

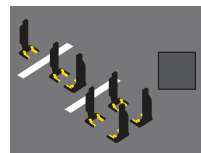

If Mode (Single/Pair/All) indicator Green – Displayed value states columns mode.  
Solo – Single column active.  
Pair – Column and other column on axle are only active pair.  
All – All columns are grouped together.

## Indicator Lights



Battery Indicator  
Green – Full Charge  
Yellow – 40% Charge - Charging recommended  
Red – 10% Charge – Charge immediately to avoid damaging batteries



5 Digit Display – Displays height, weight, mode, system ID, error codes, and menu information. Displayed information cycles on display, with indicator lights alerting user to what info is being displayed. Service menu explained in Software Menu Section.

S\_\_ System ID – Wireless identification/channel used to communicate between remote and columns. Columns and remotes need to be on same SID to communicate. S1 – S40 available.

P Press Protect - Indicates remote has entered press protect mode.

E\_\_ Error Codes – Error codes are listed in troubleshooting section of the manual (and listed on one of the decals on the column for quick reference).

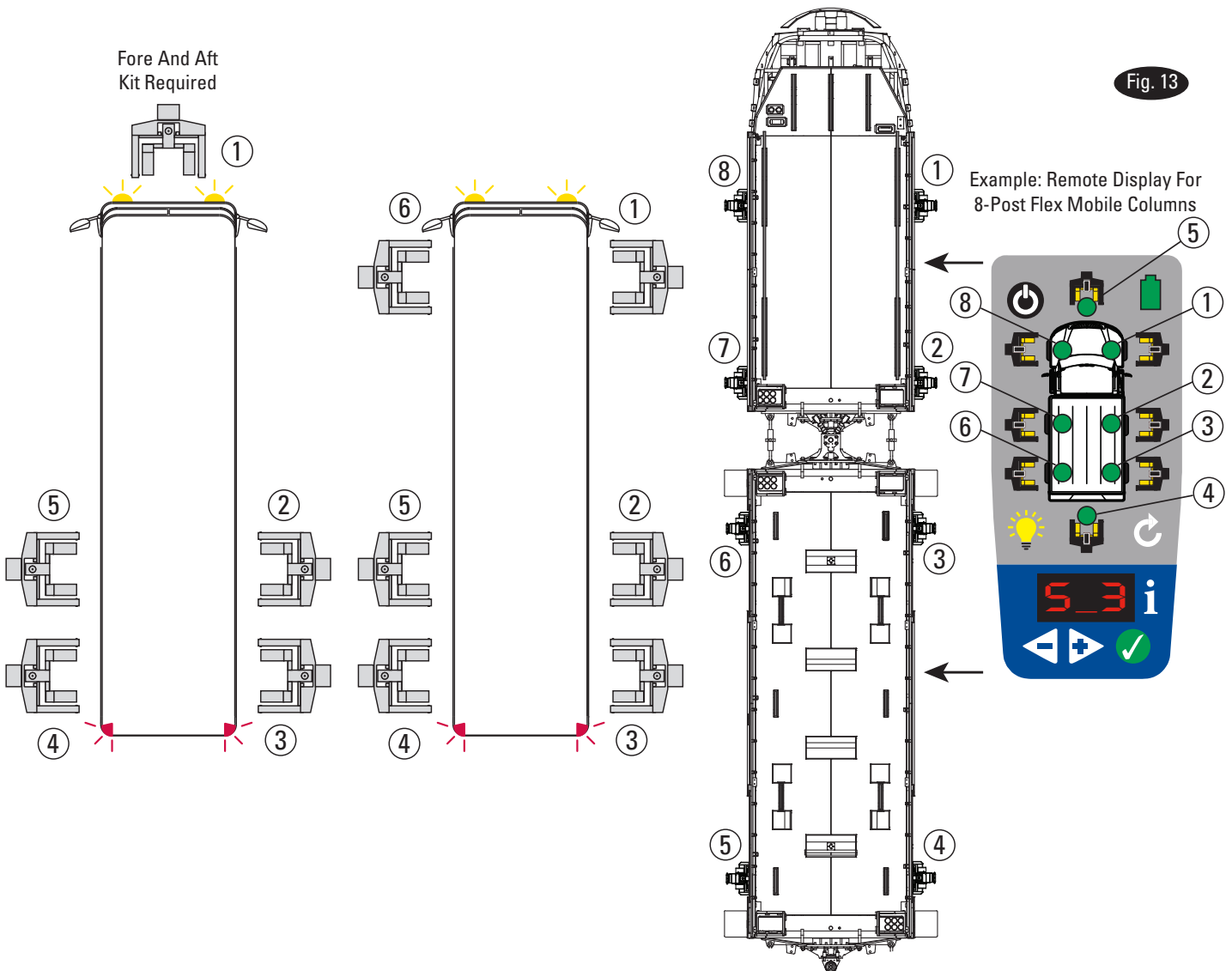
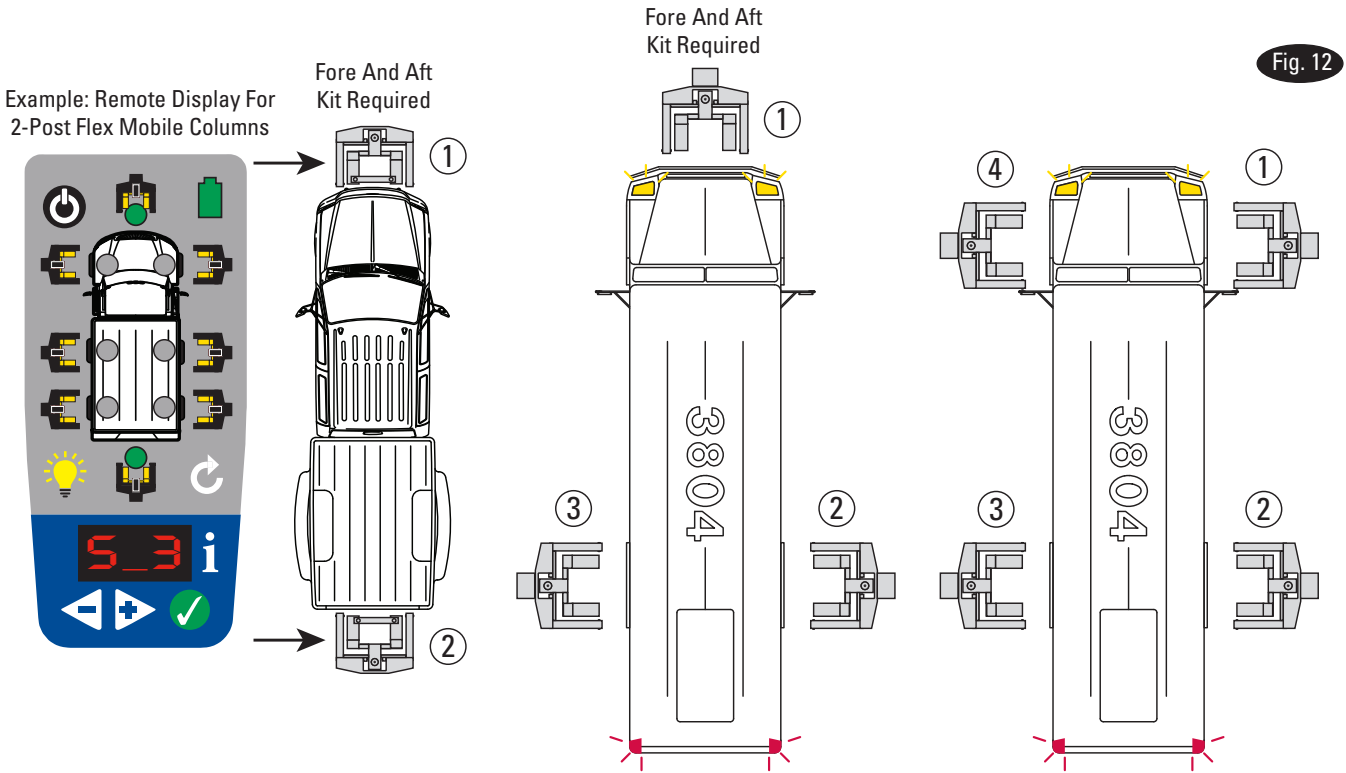

# LIFT OPERATION:

**⚠ WARNING** Before attempting to lift any vehicle, be sure that:

- a.) Vehicle individual axle weight does not exceed two lift columns combined capacity.
- b.) Lift forks are in secure contact with vehicle tires.
- c.) Adequate overhead clearance is provided to raise vehicle to desired height.
- d.) Parking brake is released on vehicle.
- e.) Adjustable forks must be equally spaced off centerline of lift carriage, and adjusted to properly accommodate the tire/wheel size.
- f.) Ensure tires are properly inflated before lifting. **DO NOT** exceed tire load rating when raising vehicle.

**Note:**

Press Protect: Remote controller goes to inactive state if no button is pressed after 5 seconds. When in this state pressing up and down will cause no movement. The remote and column will have a P displayed at the first digit. To reactivate lift press and release any motion button. All columns will flash their beacons and beep to acknowledge reactivation. Ensure desired lift beacons flash and beep to confirm correctly configured remote controller is used.

8. To Raise Lift:

- a.) Ensuring indicators for desired columns are lit in green. Press up on joystick to raise vehicle until vehicle tires clear the floor.  
Check Fork Contact: Stop and check for secure fork contact with tires, at all columns.
- b.) Continue to raise the vehicle to desired height. Listen for all locks in set to click a lock.

**NOTE:** While cycling the lift, you may observe the individual columns slowing down and speeding up at various stages of travel. This is a normal characteristic of the lift leveling system.

**NOTE:** Watch to ensure vehicle does not contact anything above it. Setting Height limit can help if consistent vehicle is used with set (discussed in software menus).

**DO NOT** go under vehicle unless all tires are in secure contact with forks. Lower lift and repeat vehicle and/or lift spotting and loading procedure if required.

- c.) Press the Lower To Locks Button to lower columns onto the locking latches. All lock lights should turn on to indicate it has been lowered off the hydraulics.

**NOTE:** If E4 error occurs when lowering to locks, it indicates columns where in different lock windows. Clear error on column with blinking E4. Press resume to unlock set. Press raise button on columns which do not have lock light lit to next lock. Lower that column to lock. Press resume on remote to re-lock set together.

While Using Lift: Avoid excessive rocking of vehicle while on the lift.

Before Lowering Lift: Remove tool trays, safety stands, etc. from area.

9. To Lower Lift:

- a.) Ensuring indicators for desired columns are light in green. Press up on joystick to raise vehicle off locks.
- b.) Press down on joystick to lower lift. Pressing all the way down is full speed lower while pressing part way down is Slow Lower (1/3 speed). Observe that all columns are lowering and vehicle remains level.
- c.) Remain clear of forks and vehicle when lowering. Observe pinch point WARNING decals.
- d.) Reset the parking brake.
- e.) Move all lift units away from the vehicle to provide an unobstructed exit before removing the vehicle.

# OPERATING INSTRUCTION DETAILS/OPTIONS

## 1. SINGLE / PAIR / ALL Using remote (Flex):

### **PAIR or GROUP mode:**

Deactivate pairs of columns which you do not want to move by selecting the column button associated with the pair. Active columns are indicated with a solid green light, while inactive columns are indicated with a yellow light. Only active columns will move when the raise/lower joystick is moved. To return to ALL mode either select deactivated column pairs or press resume.

### **SINGLE mode:**

When system locked press resume button. Columns will unlock from remote controller, and be free to be controlled individually from column lift controls, to return to ALL press resume.

## 2. Using SINGLE/PAIR/ALL button on column membrane Fig. 11.

**Change modes** pressing the Single/Pair/All button on a column. Text on the screen indicates current mode.

**ALL mode:** Default, all columns in system raise and lower together, via remote or column motion buttons.

**SINGLE/SOLO Mode:** Active column will state "SoLo" and can be raised and lowered independent from group using column motion buttons. All other columns are inactive and state "IdLE". Change active column by pressing "Single/ Pair/All" on column you wish to activate.

**PAIR Mode:** When activated the columns on the same axle will activate and the others will become inactive. Active pair of columns will state "PAIr" and can be raised and lowered together via remote or column buttons on active columns. Inactive columns will state "IdLE".

## 3. Column LED Indication – Summary of column LED's, refer to Fig. 11:

**Green Light** – Linked column that can be controlled by remote controller.

**Yellow Light** – Linked column that cannot currently be controlled by remote controller, in active pair, set in single columns mode, or columns still being set up.

**Blinking Yellow Light** – Column to be placed, remote controller looking for column to be turned on with the matching system ID selected.

**Red** – Height limit reached, height offset reached or error with column (if error on a column ALPHANUMERIC display will display code).

## 4. **RESUME** quick startup:

Power on the remote controller and press the resume button. Column ID's are confirmed and positioned as before. With a successful re-link to columns, linked columns will flash beacons and beep as well as display will indicate linked columns with solid green Lights.

## 5. Changing the System Configuration:

If pairs of columns are needed to be added or removed from the system. Turn off columns and remote controller, and restart setup process.

## 6. Swap single column from Linked group:

If a single column needs to be swapped from a group,

this can be done via standard setup process or via resume quick start.

**Note:** When possible swap columns when columns are fully on the ground to ensure proper engagement. If this is not possible use appropriate jack stand to lift load slightly off column, and position replacement column exactly as the column it replaced, then lower jack stand back onto column prior activating re-configured system.

between forks within the lift system. Software revision 8 or later is required. The height offset limit will stop lift movement once reached and column will display "HO". If a pair of columns have different offsets selected, the smallest offset will be the limit. This limit is disabled by default. Refer to software menus for setting the height offset limit.

### 7. Height Offset Limit:

The height offset limit is a limit to the height difference

## COLUMN MOUNTED MOTION BUTTONS

Fig. 14

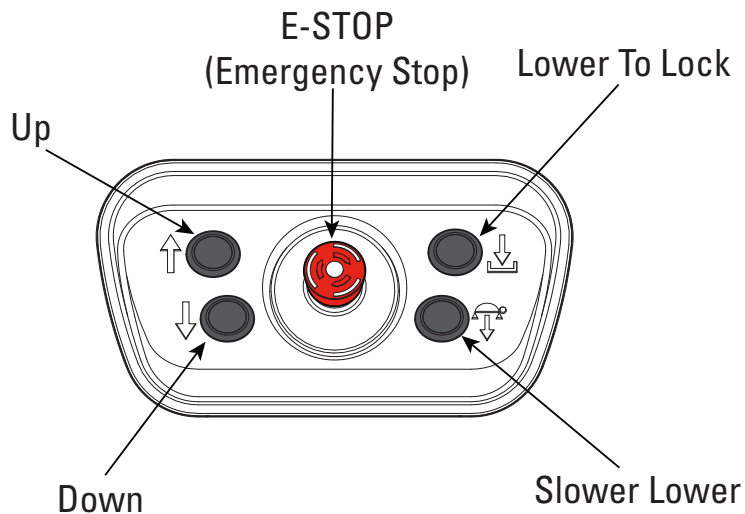

**Column mounted motion buttons move active columns. Columns that are not actively locked in a set operate independently. Columns in a set can be operated as single pair or all depending set mode currently activated by remote or column controls single/pair/all button.**

## WHEEL ENGAGING AND COLUMN MOVEMENT

1. Adjust wheel engaging forks spacing, Fig. 15:
  - a.) Tire rim diameter must be wider than spacing between forks.
  - b.) Adjust wheel forks to narrowest position which will symmetrically fit around tire.
  - c.) Confirm forks are engaged in their locking position (either pin or tabs depending on design of lift).

2. Tire Engagement to Forks, Fig. 15, Fig.16, Fig.17:
  - a.) Column fork should be centered on tire so approximately same space on both sides.
  - b.) Off-center loading can cause excess loading on sliders between Column and Carriage.
  - c.) Roll Column fully into column so tire vertical surface within  $\frac{1}{2}$ " of fork face.
  - d.) Parking Brake should be off before lifting. This will allow tire to rotate and vehicle to settle into forks.

Fig. 15

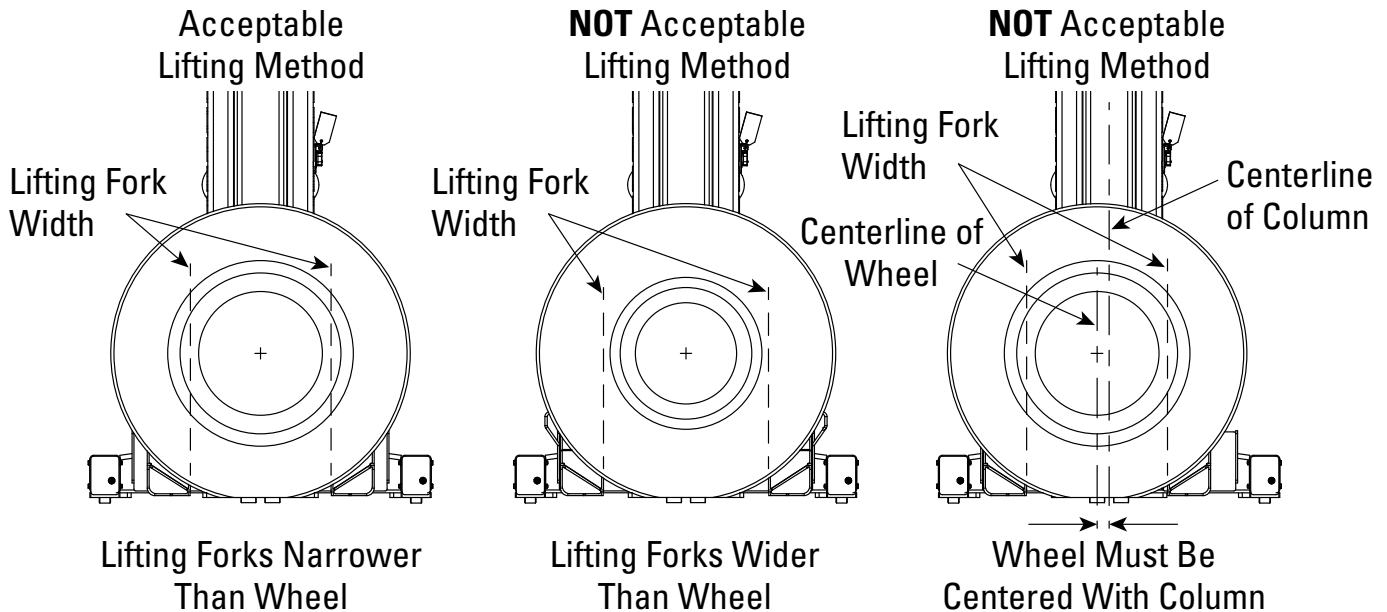

Fig. 16

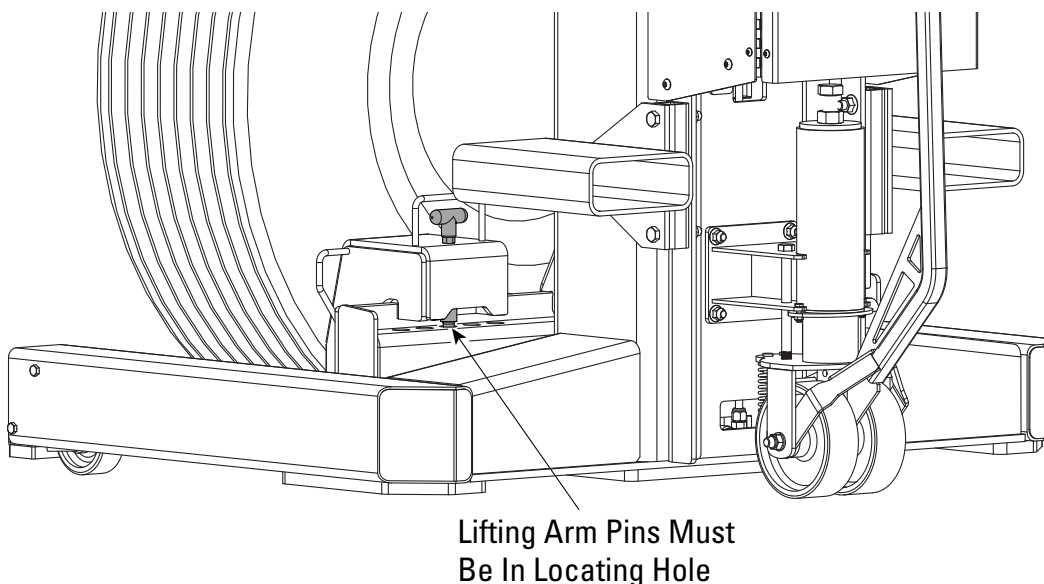
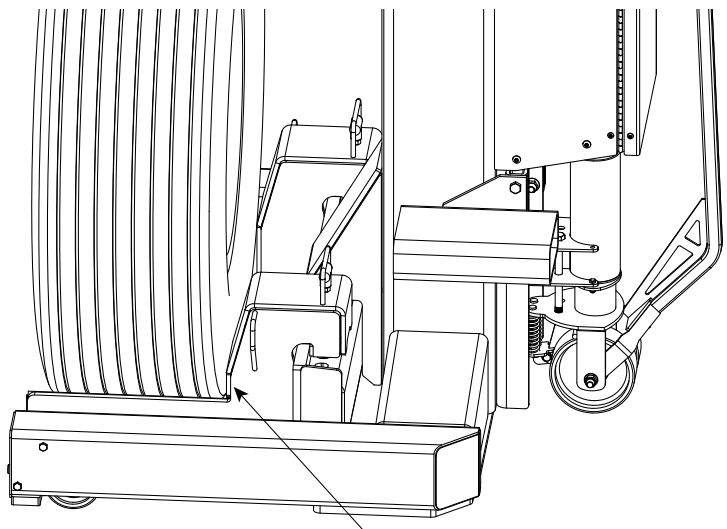

Fig. 17



Push Lift Tightly Against Wheel

3. Caster Assembly Handle:

- a.) Steering Caster assembly is spring loaded to lift column off the ground when unloaded.
- b.) Caster handle locks on wheel when handle is pivoted to the upright position, Fig. 18.
- c.) Lock intended to prevent unintended motion after column positioned, not for stopping a moving column.
- d.) Column has limited ground clearance and relatively small wheels so be sure to have a clear relatively level path when moving column.

- e.) To move column be sure column is not loaded, and pivot handle down, releasing wheel lock, and push or pull on the handle or column while steering with the handle, Fig. 19.
- f.) If moving over steeper slopes or uneven ground it may be better to move with a fork truck.
- g.) Take extra care when moving with fork truck so that column nor controls are damaged.

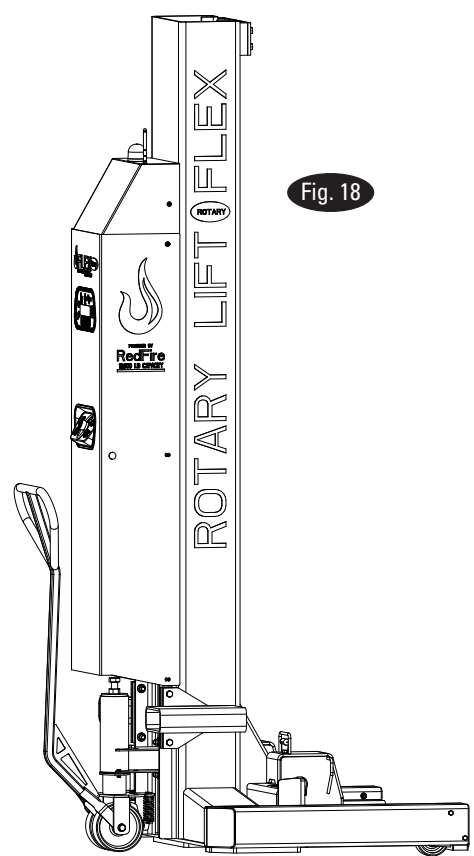

Fig. 18

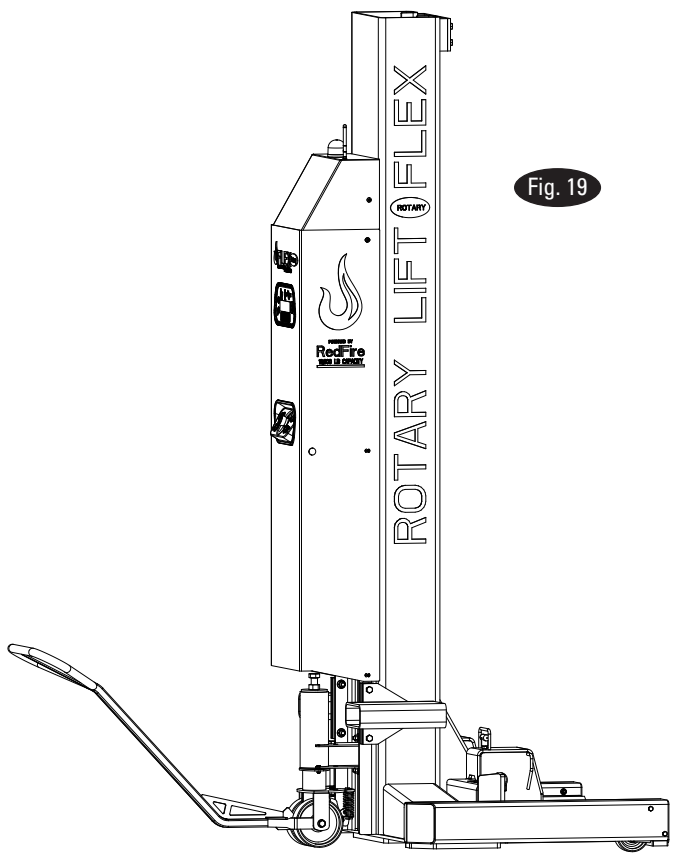

Fig. 19

# EMERGENCY STOP PROCESS

Mobile Column Emergency Stop process:

1. Always follow safe lifting practices detailed in the instruction manual according to ANSI and ALI. Clear the area if a vehicle or lift is in danger of falling.
2. First actuate the Emergency Stop Switch, Fig. 20.

3. If the Emergency Stop Switch does not affect the operation of the system or post, immediately go to the Main DC Disconnect Switch of the unresponsive unit and terminate power. This is located on the left hand side panel as looking at the control panel, Fig. 21.

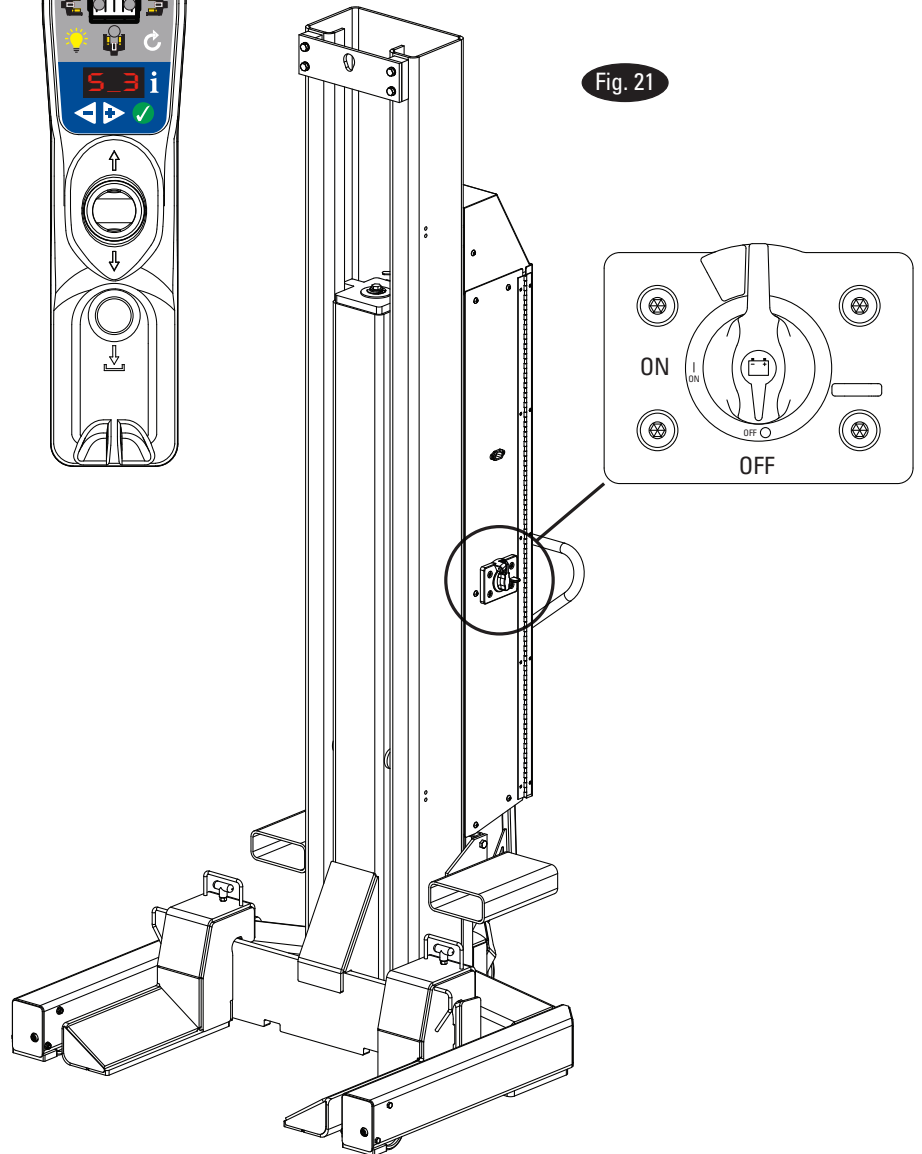
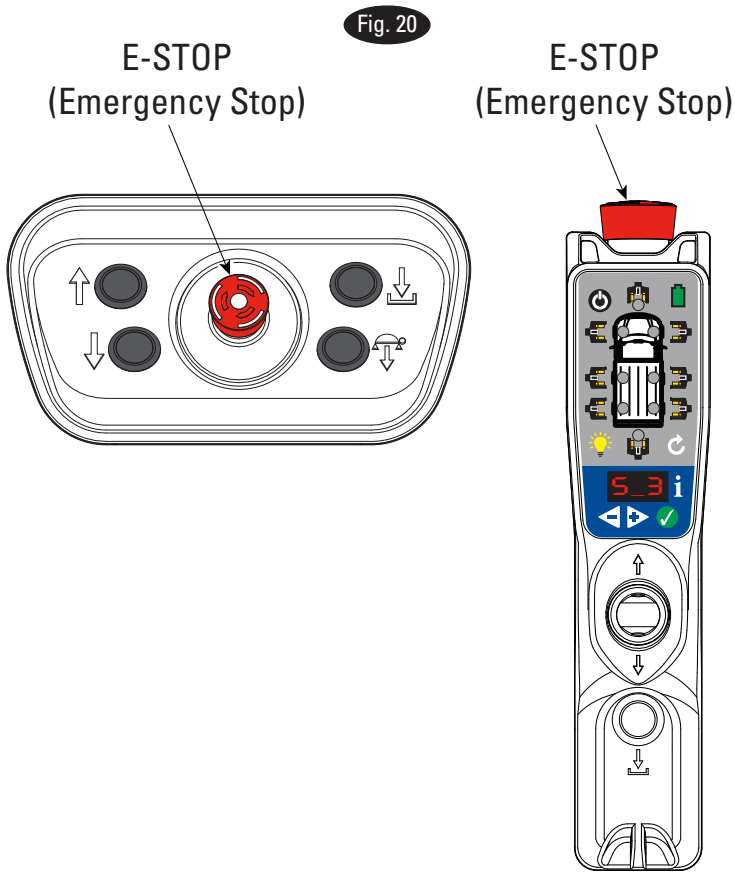

## EMERGENCY (NO POWER) LOWERING:

- During lowering of lifts, ensure that vehicle does not move into an inclined position.
- Lower columns equally.
- Remove tool trays, safety stands, etc. from area.
- Remain clear of forks and vehicle when lowering.

**NOTE:** In the event batteries become fully discharged, plug the columns into electrical outlet for approximately 15 minutes to achieve adequate charge for one operation cycle. Length may vary based on battery type, condition, etc.

- A. Remove M8 BHCS and open Power Unit Cover. Pull lock open. Push the Manual Lowering Valve Button and the carriage will begin lowering.
- C. If lift is on locks, slightly lift carriage until lock is free.
- D. Lower each carriage a small increment at a time keeping the vehicle level.
- E. Release the Manual Lowering Valve Button and the downward movement will stop.
- F. After lowering is finished, close and re-install M8 BHCS in Power Unit Cover.
- G. If lift is not operating properly, **Do Not** use until operation is corrected or repairs are made by qualified lift service personnel.

**NOTE:** Top cover not shown for clarity.

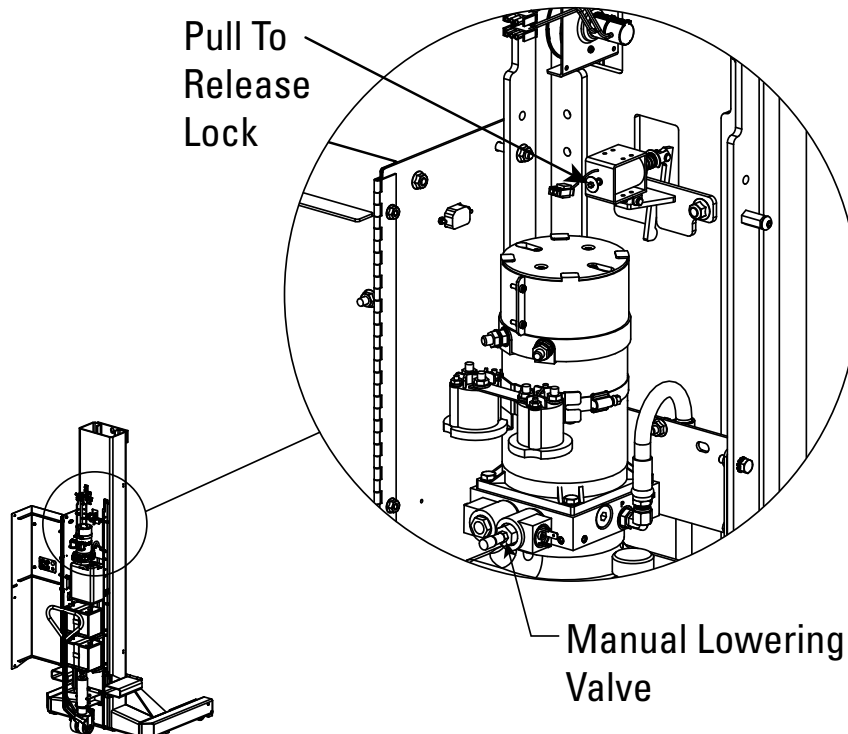

# BLEEDING COLUMN CYLINDER PROCESS

If column bounces when raising or lowering it indicates air in cylinder.

## 1. Bleeding column, Fig. 22:

- a.) Fully raise lift, then lower to just below a lock position which allows access to the bleed screw.
- b.) Loosen bleed screw slowly to release air from system. Have rag ready to prevent oily spray
- c.) Close screw as soon as oil starts to come out.
- d.) Repeat steps until there is no air in the system and fluid runs clear.

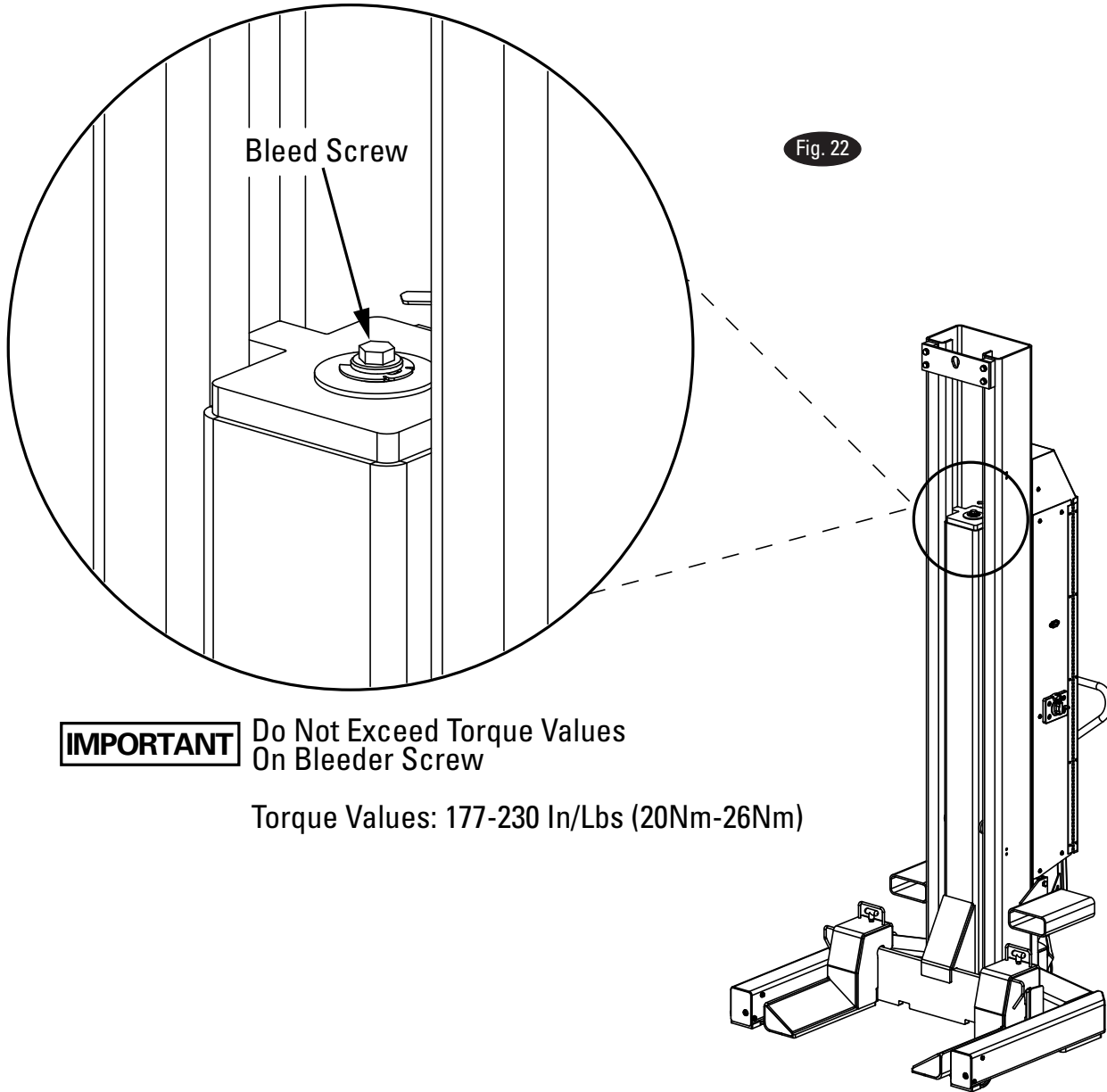

## BATTERY CHARGING

1. Battery chargers can be plugged in nearly continuously or as needed. Life of the battery can be decreased if the batteries are charged regularly (for example, after every use), and not allowed to be fully discharged. If lift will remain plugged in AGM batteries are recommended. If not, continuously plugged in marine grade deep cycle batteries are recommended.

**IMPORTANT** If marine grade deep cycle batter are used  
**Do Not** operate lift while batteries are charging.

2. When batteries are not being charged, the front panel indicator can be used to determine the battery charge level. On the front panel, a yellow light indicates that the battery is partly discharged and should be recharged. A red light indicates that you are near the end of the battery capacity and may not have enough energy left to complete a fully loaded lift cycle; the batteries must be recharged. When the batteries are being charged, the lights on the battery charger will indicate whether the battery is being charged (yellow light) or has reached full charge (green light). Indicator light is visible on the side panel of the door, just below the lift operation control box, Fig. 23.

3. Charge time will vary depending on the amount of energy that was discharged. A fully discharged battery will need to be recharged overnight to be fully restored. However, if a single lift is required, a short charge time (such as 15 minutes) should restore the batteries enough for a fully loaded lift cycle.

4. Battery performance will vary depending on the brand of battery selected, the battery specifications, how well the batteries are maintained, and the age of the batteries.

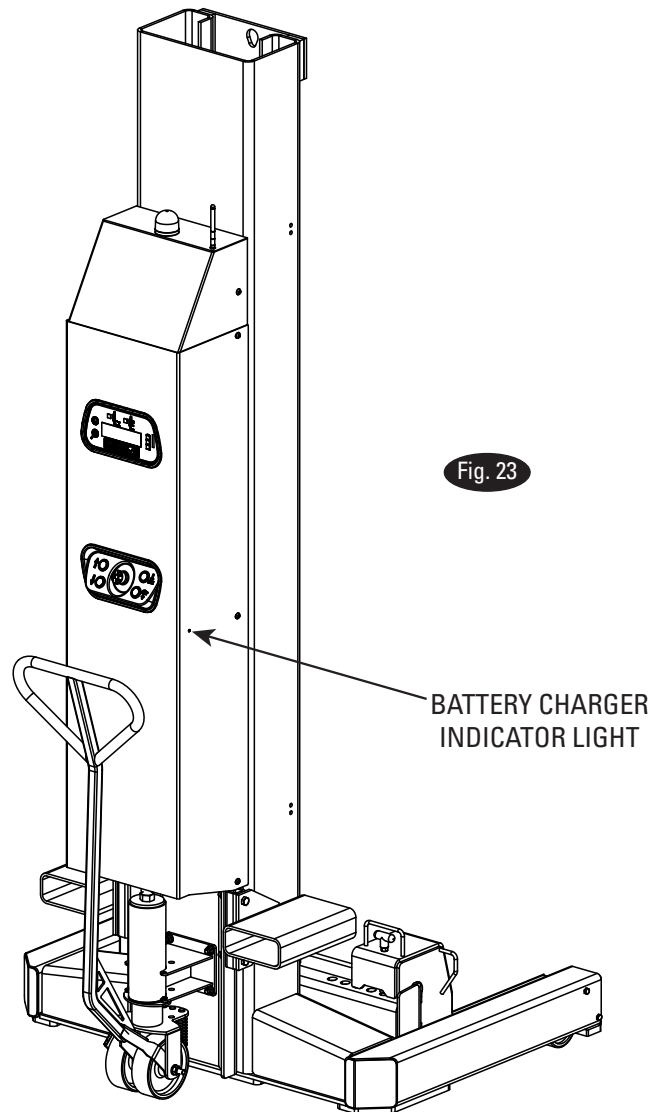

## MAINTENANCE INSTRUCTIONS

**⚠ WARNING** If you are not completely familiar with automotive lift maintenance procedures Stop: contact factory for instructions.

To Avoid Personal Injury: Permit only qualified personnel to perform maintenance on this equipment.

- Never overload lift. See capacity nameplate.
- Never direct water stream at control cabinet.
- Always keep locking latch free.
- Always keep all bolts tight.
- Always keep lift and lift area clean.
  
- Daily
  1. Check locking latch for signs of wear. Make sure latch operates freely.
  2. Check for oil leakage.
  3. Review all cables and cable connections for damage.
  4. Check forks and carriage for damage.
  
- Monthly: Check Emergency Stop: Push the “Emergency Stop” button. Columns should be inoperative with any emergency stop button depressed.
  
- Monthly Lubrication
  1. Lower lift, check oil level in oil tanks on each column: Open Power Unit Cover. Check oil level. It should just be touching the FULL line on the side of the tank. If necessary, remove oil cap and fill with ISOVG32 hydraulic oil.
  2. Oil the bushings on the jack handle and brake mechanism assembly.

- Monthly: Examine Cords: Check the condition of the charging cords on each column. Replace worn or broken cords as required.
  
- Change fluid in accordance with oil manufacturer's recommendations:
  1. Columns must be completely lowered.
  2. Remove cover panel from power unit.
  3. Remove oil from power unit tank.
  4. Refill with approximately 12 quarts (11.5 liters) of hydraulic oil meeting ISOVG32 specifications, into each tank. Fill until fluid is just touching the FULL line on the side of the tank.
  5. Check oil level in oil tanks on each column, add if necessary.
  6. Dispose of waste oil according to legal regulations.

\*MCH20 maximum operation pressure is: 2877 psi.

\*MCH19 maximum operation pressure is: 2877 psi.

\*MCH14 maximum operation pressure is: 2350 psi.

# SOFTWARE MENUS

Service menus can be accessed with wireless service menu access from Rotary Tool.

**Menus are displayed on the menu screen and can be scrolled using the up, down, and enter keys. The column will drop out of the service menu after 10 seconds of inactivity.**

**A limited service menu can be accessed with the Rotary Tool. If software revision 8 or later is installed, scroll through the columns display using the up and down menu keys until the service menu option becomes available.**

| Menu Item  | Menu Selections | Description   |
|------------|-----------------|---|
| [Height]   |                 | Shows current column height (default menu for locked columns) |
| <b>H</b>   |                 |   |
|            | HC              | Clear max. height setting                                     |
|            | HS              | Set max. height setting                                       |
| <b>P</b>   |                 |   |
|            | PC              | Clear pot calibration   |
|            | PS              | Set pot calibration   |
| <b>b</b>   |                 |   |
|            | b0              | Lowering Beeper - turn off                                    |
|            | b1              | Lowering Beeper - turn on                                     |
| <b>U</b>   |                 |   |
|            | UUS             | Height display units - US (in)                                |
|            | USI             | Height display units -metric (cm)                             |
| <b>o</b>   | [Height Offset] | Height offset limit ( IN or CM)                               |
| <b>rXX</b> |                 | Software revision level XX indicated revision number          |

**H:** Selecting **HS** sets the maximum height setting. Raise the column to the desired height and depress  once to set the value.

In operation the column that reaches its maximum height first stops all columns in the system. Selecting **HC** clears the maximum height setting.

Depress  once to clear the Max Height Value. The Maximum Height will default to the Stroke Limit Height until a new Maximum Height is set.

**P:** Depress  once to clear the value and height display calibration.

Select **PC** clears height calibration settings, which also affects the height display.







After clearing the height calibration settings, lower the forks to ground level. Select **PS**, then raise lift to maximum height and select **PS**.

**b:** **b1 (Beeper ON) or b0 (Beeper Off).** Depress  once to select. Lowering Beeper function will be active or suppressed accordingly.

**U:** **UUS (Display height in inches) or USI (Display height in centimeters).** Depress  once to select.

**o:** The height offset limit is set to "OFF" by default. Use the up and down menu buttons to select the desired height offset limit.

## TROUBLE SHOOTING

| Code                           | Description                 | Troubleshooting steps  |
|--------------------------------|-----------------------------|--|
| E0                             | CPU error                   | The processor has detected an error. Press  to clear. If the problem continues, call for service.  |
| E1                             | Improper configuration      | The column has not been assigned a position, and is connected to a locked system. Press  to clear. To add the column to the system, first power down the column, and then unlock the system. Power up the column, assign a position, then re-lock the system.   |
| E2                             | Improper column pairing     | Unless a column is run by itself in single mode, it must be selected and moved with it's pairing column. Press  to clear.   |
| E3                             | Communication Error         | 1) Check for a powered down column. If one column has been powered down, the other columns must be powered down to re-initialize the system.<br>2) Check if EStop Button is active on Remote Control. The Remote's EStop will disable communication.   |
| E4                             | Out of Level                | One or more columns in the system can not maintain level synchronization<br>1) Ensure that no columns are hung up on the safety locks<br>2) Check battery power<br>3) Check for overloading<br><br>Press  to clear. Individually move each column back into a level position. Once all the columns are level, they may be moved as a group.   |
| E5                             | Emergency Stop              | To restore operation, clear the emergency stop button at the indicated column.   |
| E6                             | Potentiometer Error         | An error has occurred with the string potentiometer, and synchronization can no longer be guaranteed. Follow manual lowering procedures.   |
| E7_<br>(E71, E72,<br>E73, E74) | Short circuit detected      | Short circuit detected in lift system. Please contact your service representative for assistance.<br><br>First instance of error can be cleared by pressing  to clear. Second instance of error can be cleared by pressing  , but error message will show up at the start of each lift cycle and until service representative has been able to troubleshoot and clear error. Third instance of error the column will be inoperable until component has been replaced and Error message reset.<br><br><b>For Service Representative only: See E7 DIAGNOSTIC TROUBLESHOOTING</b> and replace required component. To Reset Error message activate service menu using Rotary tool service menu access or install an SD service card, and press  .<br><br><b>E7 DIAGNOSTIC TROUBLESHOOTING</b><br>E71 – First contactor short: Replace first contactor (located between the disconnect and the second contactor).<br>E72 – Second contactor short: Replace second contactor (located between the first contactor and the motor).<br>E73 – (Board Relay Short): Replace control board.<br>E74 – (Board Overcurrent): An overcurrent has been detected on the lift actuators. To determine the faulty component, clear the error and run the faulty column by itself Press the buttons below in the exact order until the error is generated (control board replacement possibly required):<br>1) Up button (Error? Check/replace motor contactors and wiring)<br>2) Slow lower (Error? Check/replace small lowering valve and wiring)<br>3) Lower to Locks (Error? Check/replace large lowering valve and wiring)<br>4) Down Button (Error? Check/replace lock solenoid and wiring) |
| E8                             | Software mismatch           | Column and remote have different software versions with each other. Swap column in set or update column/remote to the latest version. Rev 8 or greater indicate rev level in service menu as "R__" and on remote flashes during remote powerup. To update software, power down column, use rotary tool following prompts along with the appropriate adapters to connect to column or remote being programmed.  |
| E9                             | Stuck Key                   | A stuck keypad button or motion push button has been detected on startup, or a motion push button has been held on for longer than 2-1/2 minutes.  |
| E10                            | Display Communication Error | Communication lost between display board and control board inside control cabinet. Check cable connections.  |

## TROUBLE SHOOTING (CONTINUED)

| Code   | Description                          | Troubleshooting steps  |
|--|--------------------------------------|--|
| E11  | Low Battery Error                    | Batteries reached critical level. Check battery charge.  |
| E13  | Weight Sensor Error                  | An error has occurred with the weight sensing device. Weight values displayed are inaccurate until next lift power cycle.  |
| E14  | Wireless Radio Error                 | An error has occurred when attempting to communicate to the column's wireless radio. Ensure that the radio modem board is powered "ON" cable(s) between the control and modem board have strong connections, and the wireless module is fully seated into the modem board. |
| E15  | Intermittent Power Fault Error       | Power to the control board has become inconsistent. Check the fuses and other power connections to the control board are strong.   |
| CL   | Communication Loss                   | Communication between columns has been lost temporarily during operation. Ensure antenna connections are secure. Re-try operation after release of button. Remote will show the columns has trouble communicating by displaying CL and the columns LED will turn red.      |
| EHL or HL  | Height Limit Reached                 | Programed height limit has been reached on column.   |
| H0   | Height Offset Limit Reached          | Programed Offset height limit has been reached on column.  |
|  | Display Unresponsive                 | Turn off power and check wire connections on the display board for the keypad, the push buttons, and the control board. Restart power and test.  |
|  | Slow To Rise                         | Overloaded, check battery and connections, dirt, debris, in oil system.  |
|  | Lift Drifts Down                     | Dirt, Debris, in oil system.   |
| <p>Receive Signal Strength Indicator (RSSI) (Inside Control Panel)</p> <p>Each transceiver has a green LED near the serial port labeled (RSSI). When operating, this LED should be on. If it is not on this indicates a poor signal due to a transceiver failure or antenna / antenna cable problem.</p> |                                      |  |
|  |                                      |  |
| <b>Trouble</b>   | <b>Cause</b>                         | <b>Remedy</b>  |
| Lift will not raise off of latches.  | 1. Motor, pump, or cylinder failure. | 1. Contact lift manufacturer's Customer Service.   |

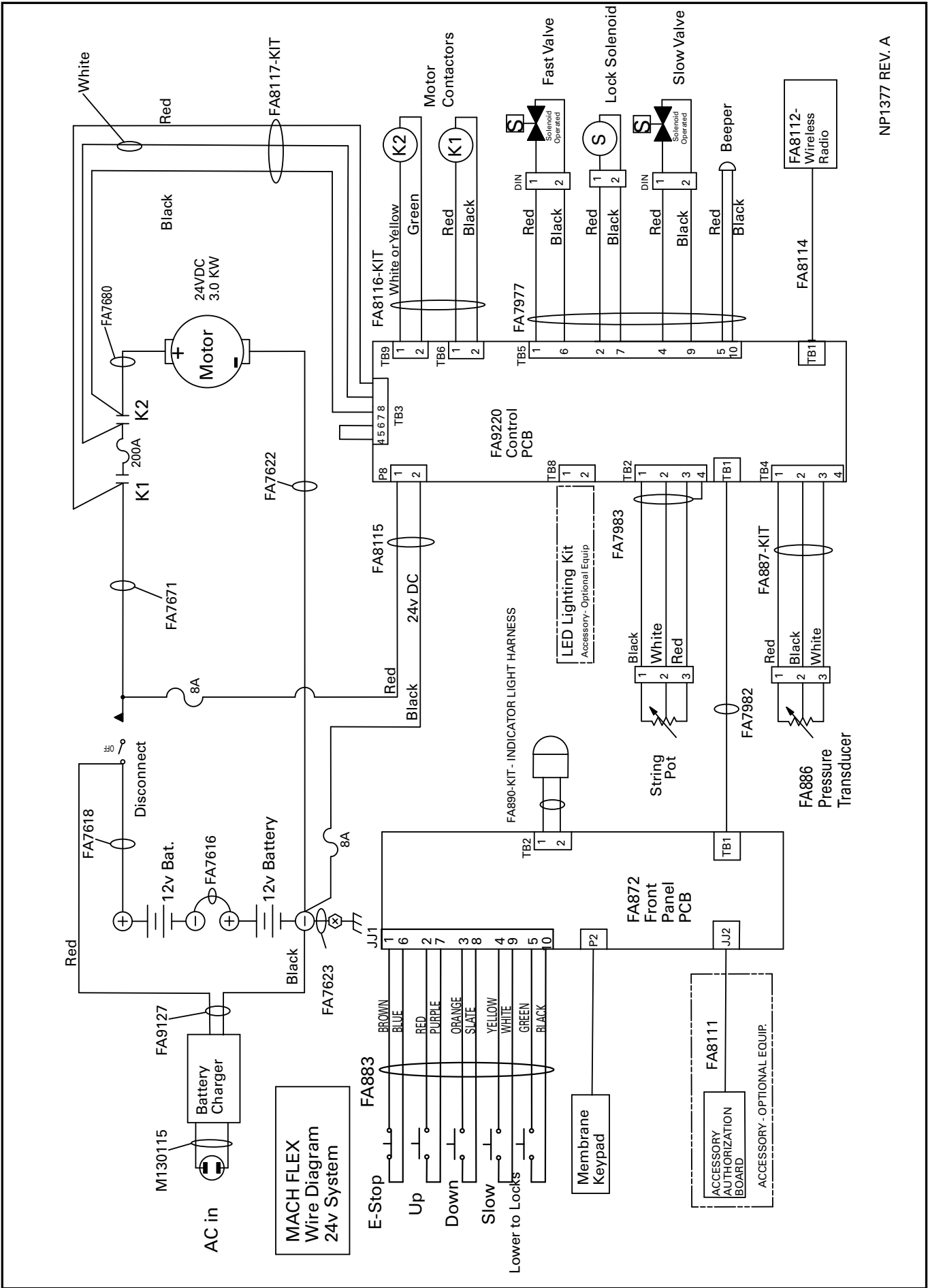

# SAFETY INFORMATION

## IMPORTANT SAFETY INSTRUCTIONS

### KEEP THESE INSTRUCTIONS!

The battery charger is a powerful electrical device. If incorrectly installed, configured or operated, the battery charger can damage batteries and/or electrical equipment. Please read thoroughly the instructions and safety information contained in the charger manual before operating the battery charger.

**⚠ WARNING** RISK OF EXPLOSIVE GASES

WORKING IN THE VICINITY OF A LEAD ACID BATTERY IS DANGEROUS. BATTERIES CONTAIN SULFURIC ACID AND PRODUCE EXPLOSIVE GASES. A BATTERY EXPLOSION COULD RESULT IN LOSS OF EYESIGHT OR SERIOUS BURNS. FOR THIS REASON, IT IS OF UTMOST IMPORTANCE THAT YOU FOLLOW THE INSTRUCTIONS EACH TIME YOU USE THE CHARGER.

TO REDUCE THE RISK OF BATTERY EXPLOSION, FOLLOW THESE INSTRUCTIONS AND THOSE PUBLISHED BY THE BATTERY MANUFACTURER FOR ANY EQUIPMENT YOU INTEND TO USE IN THE VICINITY OF THE BATTERY. REVIEW CAUTIONARY MARKINGS ON THESE PRODUCTS AND ON ENGINE, MOTOR OR OTHER EQUIPMENT REQUIRING BATTERY USAGE.

Refer to charger manual, it contains important safety and operating instructions applicable to the safe and efficient use of your battery charger. To reduce risk of damage to electric plug or cord, pull by the plug rather than the cord when disconnecting the battery charger.

An extension cord should not be used unless absolutely necessary. Use of improper extension cord could result in a risk of fire or electric shock. If extension cord must be used, make sure:

- a.) That pins of plug of the extension cord are the same number, size and shape of those of the plug on the battery charger;
- b.) That extension cord is properly wired and in good electrical condition;
- c.) That wire in extension cord is proper size as follows:

Minimum recommended AWG wire size for various length extension cords used with each battery charger:

| Length of Cord in feet | 25 | 50 | 100 |
|------------------------|----|----|-----|
| AWG Size               | 16 | 14 | 12  |

Do not operate the battery charger with a damaged cord or plug.

Do not operate the battery charger if it has received a sharp blow, been dropped or otherwise damaged in any way.

Do not disassemble the charger. Incorrect reassembly may result in a risk of electric shock or fire.

To reduce the risk of electric shock, unplug the charger from outlet before attempting any maintenance or cleaning. Disconnecting the leads will not reduce this risk.

To reduce the risk of shock or spark, never touch the ring terminals together while the charger is plugged into an outlet or extension cord.

External connections to the battery charger shall comply with all local, state, and federal regulations.

### RF Exposure:

**WARNING:** To satisfy FCC RF exposure requirements for mobile transmitting devices, a separation distance of 20cm or more should be maintained between the antenna of the device and persons during device operation. To ensure compliance, operations at closer than this distance is not recommended. The antenna used for this transmitter must not be co-located in conjunction with any other antenna or transmitter.

### Notices:

This equipment has been tested and found to comply with the limits of a Class B digital device, pursuant to Part 15 of the FCC Rules. These limits are designed to provide reasonable protection against harmful interference in a residential installation. This equipment generates, uses and can radiate radio frequency energy and, if not installed and used in accordance with the instructions, may cause harmful interference to radio communications. However, there is no guarantee that interference will not occur in a particular installation.

If this equipment does cause interference, which can be determined by turning equipment off and on, the user is encouraged to try to correct the interference by one or more of the following measures: Increase the separation between the equipment. Connect equipment to outlets on different circuits.

| <b>⚠ CAUTION ⚠</b><br>Remove from hazardous area prior to opening.   | <b>⚠ ATTENTION ⚠</b><br>Retirer de la zone dangereuse avant ouverture.   |
|--|--|
| FA845 - Pendant for hazardous locations Class 1, Div. 2, Group D Li-Ion Battery 7.4VDC, 520mA (MAX) For Indoor Use (5°-40° C) Temperature Code T6<br>FCC ID: OUR-XBEEPRO NP1224 Rev. - | FA845 - Poignée de commande pour emplacements dangereux Classe 1, Div. 2, Groupe D Pour une utilisation en intérieur (5°-40° C) Code de température T6 |

**Installer:** Please return this booklet to literature package, and give to lift owner/operator.

**Thank You**

Trained Operators and Regular Maintenance Ensures Satisfactory Performance of Your Rotary Lift.

Contact Your Nearest Authorized Rotary Parts Distributor for Genuine Rotary Replacement Parts. See Literature Package for Parts Breakdown.

**Rotary World Headquarters**

2700 Lanier Drive  
Madison, IN 47250, USA  
www.rotarylif.com

**North America Contact Information**

Tech. Support:  
p 800.445.5438  
f 800.578.5438  
e userlink@rotarylif.com  
Sales:  
p 800.640.5438  
f 800.578.5438  
e userlink@rotarylif.com

**World Wide Contact Information**

World Headquarters/USA: 1.812.273.1622  
Canada: 1.905.812.9920  
European Headquarters/Germany: +49.771.9233.0  
United Kingdom: +44.178.747.7711  
Australasia: +60.3.7660.0285  
Latin America / Caribbean: +54.3488.431.608  
Middle East / Northern Africa: +49.771.9233.0

**© Vehicle Service Group<sup>SM</sup>**

Printed in U.S.A., All Rights Reserved. Unless otherwise indicated, ROTARY, and all other trademarks are property of Dover Corporation and its affiliates.

